



**LAS VIRGENES MUNICIPAL WATER DISTRICT**  
4232 Las Virgenes Road, Calabasas, CA 91302

**AGENDA**  
**REGULAR MEETING**

Members of the public wishing to address the Board of Directors are advised that a statement of Public Comment Protocols is available from the Clerk of the Board. Prior to speaking, each speaker is asked to review these protocols and **MUST** complete a speakers' card and hand it to the Clerk of the Board. Speakers will be recognized in the order cards are received.

The **Public Comments** agenda item is presented to allow the public to address the Board on matters not on the agenda. The public may present comments on any agenda item at the time the item is called upon for discussion.

Materials prepared by the District in connection with subject matter on the agenda are available for public inspection at 4232 Las Virgenes Road, Calabasas, CA 91302. Materials prepared by the District and distributed to the Board during this meeting are available for public inspection at the meeting or as soon thereafter as possible. Materials presented to the Board by the public will be maintained as part of the records of these proceedings and are available upon written request to the Clerk of the Board.

---

5:00 PM

May 24, 2016

**PLEDGE OF ALLEGIANCE**

- 1 **CALL TO ORDER AND ROLL CALL**
- 2 **APPROVAL OF AGENDA**
- 3 **PUBLIC COMMENTS**

Members of the public may now address the Board of Directors **ON MATTERS NOT APPEARING ON THE AGENDA**, but within the jurisdiction of the Board. No action shall be taken on any matter not appearing on the agenda unless authorized by Subdivision (b) of Government Code Section 54954.2

4 **CONSENT CALENDAR**

A **List of Demands: May 24, 2016 (Pg. 4)**

Approve

B **Minutes: Regular Meeting of May 10, 2016 (Pg. 35)**

Approve

C **Cash and Investment Report for April 2016 (Pg. 42)**

Receive and file the Cash and Investment Report for April 2016.

D **Supply and Delivery of Pressure Regulators: Award (Pg. 54)**

Accept the bid from Ferguson Waterworks for the annual supply and delivery of pressure regulators and authorize the General Manager to approve an initial 13-month purchase order, in the amount of \$85,003.65, with four one-year renewal options for the same amount.

5 **ILLUSTRATIVE AND/OR VERBAL PRESENTATION AGENDA ITEMS**

A **Legislative and Regulatory Updates**

B **Water Supply Conditions and Drought Response (Pg. 61)**

6 **TREASURER**

7 **FACILITIES AND OPERATIONS**

A **2015 Urban Water Management Plan: Adoption (Pg. 64)**

Pass, approve and adopt Resolution No. 2493, adopting the 2015 Urban Water Management Plan.

**RESOLUTION NO. 2493**

**A RESOLUTION OF THE BOARD OF DIRECTORS OF THE LAS VIRGENES MUNICIPAL WATER DISTRICT ADOPTING THE 2015 URBAN WATER MANAGEMENT PLAN**

(Reference is hereby made to Resolution No. 2493 on file in the District's Resolution Book and by this reference the same is incorporated herein.)

B **Twin Lakes Tanks Drainage Project: Award of Construction Contract (Pg. 67)**

Find that the project is categorically exempt from the California Environmental Quality Act; waive a minor bid irregularity and award a construction contract to Spiess Construction Company, Inc., in the amount of \$201,366; approve an increase, in the amount of \$4,760, to the an existing contract with Phoenix Civil Engineering; and authorize the General Manager to execute a Temporary Construction and Permanent Easement Agreement for the Twin Lakes Tanks Drainage Project.

8 **NON-ACTION ITEMS**

A **Organization Reports**

(1) MWD Representative Report

(2) Other

**B Director's Reports on Outside Meetings**

**C General Manager Reports**

(1) General Business

(2) Follow-Up Items

**D Director's Comments**

**9 FUTURE AGENDA ITEMS**

**10 PUBLIC COMMENTS**

Members of the public may now address the Board of Directors **ON MATTERS NOT APPEARING ON THE AGENDA**, but within the jurisdiction of the Board. No action shall be taken on any matter not appearing on the agenda unless authorized by Subdivision (b) of Government Code Section 54954.2

**11 CLOSED SESSION**

**A Conference with District Counsel – Existing Litigation (Government Code Section 54956.9(a)):**

1. Las Virgenes - Triunfo Joint Powers Authority v. United States Environmental Protection Agency and Heal the Bay, Inc. v. Lisa P. Jackson (TMDL cases)
2. Las Virgenes - Triunfo Joint Powers Authority v. United States Environmental Protection Agency (FOIA case)

**B Public Employee Performance Evaluation (Government Code Section 54957(b)):**

Title: General Manager

**12 OPEN SESSION AND ADJOURNMENT**

Pursuant to Section 202 of the Americans with Disabilities Act of 1990 (42 U.S.C. Sec. 12132), and applicable federal rules and regulations, requests for a disability-related modification or accommodation, including auxiliary aids or services, in order to attend or participate in a meeting, should be made to the Executive Assistant/Clerk of the Board in advance of the meeting to ensure availability of the requested service or accommodation. Notices, agendas, and public documents related to the Board meetings can be made available in appropriate alternative format upon request.

LAS VIRGENES MUNICIPAL WATER DISTRICT

To: JAY LEWITT, TREASURER

Payments for Board Meeting of : May 24, 2016

Upon certification by the Treasurer the checks and wire transfers were correct and supporting documents available, it is recommended the following demands on the various funds be approved and payments authorized.

Wells Fargo Bank A/C No. 4806-994448

Checks Nos. 72947 through 73105 were issued in the total amount of \$ 805,323.19

Payments through wire transfers as follows:

None

Total payments \$ 805,323.19

(Reference is hereby made to these demands on file in the District's Check Register and by this reference the same is incorporated herein and made a part hereof.)

**CHECK LISTING FOR BOARD MEETING  
05/24/16**

Company Name	Company No.	Check No.	Check No.	Check No.	Total
		72947 thru 72952 05/10/16	72953 thru 72967 05/17/16	72968 thru 73105 05/24/16	
		Amount	Amount	Amount	
Potable Water Operations	101	17,982.48	64,523.90	48,357.14	130,863.52
Recycled Water Operations	102		406.55		406.55
Sanitation Operations	130	81,305.00	2,654.05	78,163.77	162,122.82
Potable Water Construction	201				0.00
Water Conservation Construction	203				0.00
Potable Water Replacement	301		295.46	62,826.32	63,121.78
Reclaimed Water Replace	302				0.00
Internal Service	701	4,535.27	19,892.98	143,350.01	167,778.26
JPA Operations	751	455.40	126,983.25	96,274.86	223,713.51
JPA Construction	752				0.00
JPA Replacement	754			70,272.30	70,272.30
<b>Total Printed</b>		<b>104,278.15</b>	<b>214,756.19</b>	<b>499,244.40</b>	<b>818,278.74</b>
<b>Voided Checks/ payment stopped:</b>					
Ck#69080	701	(12,955.55)			(12,955.55)
<b>Total Voids</b>		<b>(12,955.55)</b>	<b>0.00</b>	<b>0.00</b>	<b>(12,955.55)</b>
<b>Net Total</b>		<b>91,322.60</b>	<b>214,756.19</b>	<b>499,244.40</b>	<b>805,323.19</b>

Batch Number - 244620  
Bank Account - 00146807 Cash-General

Payment Number	Payment Date	Address Number	Name	Payment Sub Message	Document Ty	Document Number	Key Item	Key Co	Amount	Invoice Number
72947	05/10/16	2669	AT&T	SRV 4/25-5/24/16	PV	145811	001	00101	99.71	0192/042516
				SRV 4/23-5/22/16	PV	145812	001	00101	101.59	7426/042316
				SRV 4/23-5/22/16	PV	145813	001	00101	101.59	5388/042316
				SRV 4/23-5/22/16	PV	145814	001	00101	107.04	2430/042316
				SRV 4/23-5/22/16	PV	145815	001	00101	180.26	0210/042316
				SRV 4/23-5/22/16	PV	145816	001	00701	110.27	1984/042316
				Payment Amount					700.46	
72948	05/10/16	2536	CITY OF LOS ANGELES	SWG CHG-FY14-15	PV	145826	001	00130	44,791.00	74WP160000119
				RECON-O&M						
				SWG CHG-FY14-15	PV	145827	001	00130	36,514.00	74WP160000120
				RECON-CAP						
				Payment Amount					81,305.00	
72949	05/10/16	2658	FEDERAL EXPRESS CORP	2 PKG DEL 4/21&4/26/16	PV	145801	001	00701	55.36	5-400-51358
				Payment Amount					55.36	
72950	05/10/16	6770	G.I. INDUSTRIES	4/16-4/25/16 TAPIA DISP	PV	145809	001	00701	455.40	2525991-0283-4
				4/16-4/25/16 SHOP DISP	PV	145810	001	00701	357.62	2767000-0283-1
				Alt Payee						
			6771 G.I. INDUSTRIES							
			P. O. BOX 541065							
			LOS ANGELES CA 90054-1065							
				Payment Amount					813.02	
72951	05/10/16	3025	WATER & SANITATION SRV/VENTURA COUNTY	PURCH WTR 3/15-4/19/16	PV	145802	001	00101	17,392.29	1255554
				Payment Amount					17,392.29	
72952	05/10/16	3067	XEROX CORPORATION	3/16 LEASE-HQ&TAPIA	PV	145743	001	00701	3,809.70	701963697
				4/16 5945APT A	PV	145800	001	00701	202.32	084460361

Batch Number - 244620  
Bank Account - 00146807 Cash-General

Las Virgenes Municipal Water  
AVP Auto Payment Register

Payment Number	Date	Address Number	Name	Payment Stub Message	Document Ty Number	Key lim Co	Amount	Invoice Number
-------------------	------	-------------------	------	----------------------	-----------------------	---------------	--------	-------------------

OPS

Payment Amount . 4,012.02

Total Amount of Payments Written 104,278.15

Total Number of Payments Written 6

Batch Number - 244869  
Bank Account - 00146807 Cash-General

Payment Number	Payment Date	Address Number	Name	Payment Stub Message	Document Ty	Document Number	Key Item	Key Co	Amount	Invoice Number
72953	05/17/16	2869	AT&T	SRV 5/5-6/4/16	PV	146008	001	00701	543.67	9268/050516
				SRV 5/5-6/4/16	PV	146009	001	00101	109.85	9054/050516
				SRV 5/5-6/4/16	PV	146010	001	00701	542.12	9065/050516
				SRV 5/5-6/4/16	PV	146012	001	00701	571.18	992789332X051
				SRV 4/4-5/3/16	PV	146012	002	00701	41.50	12016
				SRV 4/4-5/3/16	PV	146012	003	00701	18.39	992789332X051
				SRV 4/4-5/3/16	PV	146012	004	00701	452.06	12016
				SRV 4/4-5/3/16	PV	146012	005	00701	30.96	992789332X051
				SRV 4/4-5/3/16	PV	146012	006	00701	49.35	12016
				SRV 4/4-5/3/16	PV	146012	007	00701	60.14	992789332X051
				SRV 4/4-5/3/16	PV	146012	008	00701	18.39	12016
				SRV 4/4-5/3/16	PV	146012	009	00701	12.87	992789332X051
				SRV 4/4-5/3/16	PV	146012	010	00701	5.52	12016
				SRV 4/4-5/3/16	PV	146012	011	00701	238.90	992789332X051
				SRV 4/4-5/3/16	PV	146012	012	00701	225.63	12016
				SRV 4/4-5/3/16	PV	146012	013	00701	30.96	992789332X051
				SRV 4/4-5/3/16	PV	146012	014	00701	277.63	12016
				SRV 4/4-5/3/16	PV	146012	015	00701	18.39	992789332X051
				SRV 4/4-5/3/16	PV	146012	016	00701	65.63	12016
				SRV 4/4-5/3/16	PV	146012	017	00701	49.35	992789332X051
				SRV 4/4-5/3/16	PV	146012	017	00701	49.35	12016



Batch Number - 244869  
Bank Account - 00146807 Cash-General

Payment Number	Payment Date	Address Number	Name	Payment Stub Message	Ty	Document Number	Key Item	Key Co	Amount	Invoice Number
				SRV	PV	146012	018	00701	61.92	992789332X051
				4/4-5/3/16						12016
				SRV	PV	146012	019	00701	109.95	992789332X051
				4/4-5/3/16						12016
				SRV	PV	146012	020	00701	19.38	992789332X051
				4/4-5/3/16						12016
				SRV	PV	146012	021	00701	65.63	992789332X051
				4/4-5/3/16						12016
				SRV	PV	146012	022	00701	91.29	992789332X051
				4/4-5/3/16						12016
				SRV	PV	146012	023	00701	160.62	992789332X051
				4/4-5/3/16						12016
				Payment Amount					2,675.64	
72955	05/17/16	18654	AT&T TELECONFERENC E SERVICES	CONF CALLS-APR'16	PV	146011	001	00751	23.66	605-015431
				CONF CALLS-APR'16						605-015431
				Payment Amount					140.26	
72956	05/17/16	17918	EARTHLINK BUSINESS CO.	MAY'16 MPLS LINES	PV	145917	001	00701	4,288.95	1318062505011
				Payment Amount					4,288.95	60
72957	05/17/16	6770	G.I. INDUSTRIES	5/16 HQ&SHOP DISP	PV	145920	001	00701	626.90	2767128-0283-
				5/16 RLV-FARM DISP					85.08	0
				5/16 RLV DISP					85.08	2767127-0283-
				5/16 TAPIA DISP					740.35	2767126-0283-
				5/16 WLK DISP					236.04	2526002-0283-
				5/16 TAPIA GRIT DISP					343.20	2412262-0283-
				Payment Amount					2,116.65	2526003-0283-
				Payment Amount					141.07	0896/050416
				Payment Amount					141.07	
				Payment Amount					141.07	

All Payee 6771 G.I. INDUSTRIES  
P. O. BOX 541065  
LOS ANGELES CA 90054-1065

3352 LAS VIRGENES  
MUNICIPAL

Batch Number - 244869  
Bank Account - 00146807 Cash-General

Payment Number	Payment Date	Address Number	Name	Payment Stub Message	Document Ty	Number	Key Ltm	Co	Amount	Invoice Number
			WATER DISTRICT							
				RWPS	PV	145755	001	00701	72.63	2645/050416
				3/29-4/27/16						
				BLDG#8 RW	PV	145756	001	00701	103.43	2646/050416
				3/29-4/27/16						
				BLDG#8 RW	PV	145757	001	00701	161.72	2652/050416
				3/29-4/27/16						
				BLDG#7 RW	PV	145758	001	00701	105.44	2655/050416
				3/29-4/27/16						
				INDIAN HILLS	PV	145759	001	00751	9.15	0558/050416
				3/30-4/27/16						
				MORRISON P/S	PV	145760	001	00751	9.15	0331/050416
				3/30-4/27/16						
				WLK	PV	145761	001	00101	329.39	0907/050416
				3/25-4/27/16						
				WLK	PV	145762	001	00101	241.00	0909/050416
				3/25-4/27/16						
				SDDL TREE Tnk	PV	145763	001	00301	295.46	8657/050416
				IMPV						
				3/31-4/29/16						
				Payment Amount					1,468.44	
72959	05/17/16	2839	MOTION INDUSTRIES, INC.	RTN SF-36 4 BOLT FLG	PD	144827	001	00130	2,105.35-	CA22-601460
				BULK FITTINGS	PV	145030	001	00701	97.66	CA22-602633
				TRI-POWER	PV	145031	001	00701	31.02	CA22-602263
				BELTS						
				ADAPTRS&HOSES	PV	145043	001	00701	574.86	CA22-602697
				HYD	PV	145713	001	00701	561.44	CA22-603999
				HOSES&HOSE						
				ENDS						
				PIL BLK BALL	PV	145714	001	00701	622.62	CA22-603579
				BRG						
				4 HI-PWR	PV	145724	001	00701	53.44	CA22-604136
				V-BELTS						
				3 FITTINGS	PV	146000	001	00701	218.25	CA22-604521
				2 BLK FLANGES	PV	146001	001	00701	162.00	CA22-604294
				6 TRUFLEX	PV	146002	001	00701	38.18	CA22-604241
				BELTS						
				3 SS FITTINGS	PV	146003	001	00701	237.78	CA22-604466

Batch Number - 244869  
Bank Account - 00146807 Cash-General

Payment Number	Payment Date	Address Number	Name	Payment Stub Message	Ty	Document Number	Key Item	Key Co	Amount	Invoice Number
			Alt Payee 10317 MOTION INDUSTRIES INC. FILE 749376 LOS ANGELES CA 90074		PV	146004	001	00701	114.21	CA22-604405
				4 WKA HYDRCLC GAUGES						
				6 NWO-SS FITTINGS	PV	146013	001	00701	170.45	CA22-604645
72960	05/17/16	2957	SOUTHERN CALIFORNIA EDISON	Payment Amount RLV COMPST PLNT 4/1-5/2/16	PV	145823	001	00751	20,578.07	5165-46/05051 6
				Payment Amount					776.56	
72961	05/17/16	2957	SOUTHERN CALIFORNIA EDISON	Payment Amount RW P/S 4/1-5/2/16	PV	145824	001	00751	30,268.08	4500-42/05061 6
				Payment Amount					20,578.07	
72962	05/17/16	2957	SOUTHERN CALIFORNIA EDISON	Payment Amount ENERGY-APR'16	PV	145825	001	00101	2,536.02	2869/050416
				ENERGY-APR'16	PV	145825	002	00101	27.08	2869/050416
				ENERGY-APR'16	PV	145825	003	00101	434.94	2869/050416
				ENERGY-APR'16	PV	145825	004	00101	25.92	2869/050416
				ENERGY-APR'16	PV	145825	005	00101	69.10	2869/050416
				ENERGY-APR'16	PV	145825	006	00101	18.93	2869/050416
				ENERGY-APR'16	PV	145825	007	00101	16.80	2869/050416
				ENERGY-APR'16	PV	145825	008	00101	11.20	2869/050416
				ENERGY-APR'16	PV	145825	009	00101	25.92	2869/050416
				ENERGY-APR'16	PV	145825	010	00101	29.65	2869/050416
				ENERGY-APR'16	PV	145825	011	00101	27.19	2869/050416
				ENERGY-APR'16	PV	145825	012	00101	2,239.00	2869/050416
				ENERGY-APR'16	PV	145825	013	00101	5,052.02	2869/050416
				ENERGY-APR'16	PV	145825	014	00101	52.58	2869/050416
				ENERGY-APR'16	PV	145825	015	00101	7,256.28	2869/050416
				ENERGY-APR'16	PV	145825	016	00101	5,182.15	2869/050416
				ENERGY-APR'16	PV	145825	017	00101	27.27	2869/050416
				ENERGY-APR'16	PV	145825	018	00101	124.11	2869/050416
				ENERGY-APR'16	PV	145825	019	00101	3,082.73	2869/050416
				ENERGY-APR'16	PV	145825	020	00101	12,321.02	2869/050416
				ENERGY-APR'16	PV	145825	021	00101	49,284.07	2869/050416
				ENERGY-APR'16	PV	145825	022	00101	28.50	2869/050416

Batch Number - 244869

Bank Account - 00146807 Cash-General

Payment Number	Date	Address Number	Name	Payment Stub Message	Ty	Document Number	Key Item	Key Co	Amount	Invoice Number
ENERGY-APR16					PV	145825	023	00101	660.47	2869/050416
ENERGY-APR16					PV	145825	024	00101	697.07	2869/050416
ENERGY-APR16					PV	145825	025	00101	4,841.97	2869/050416
ENERGY-APR16					PV	145825	026	00101	366.49	2869/050416
ENERGY-APR16					PV	145825	027	00101	819.89	2869/050416
ENERGY-APR16					PV	145825	028	00101	625.24	2869/050416
ENERGY-APR16					PV	145825	029	00101	2,513.70	2869/050416
ENERGY-APR16					PV	145825	030	00101	29.40	2869/050416
ENERGY-APR16					PV	145825	031	00101	1,014.75	2869/050416
ENERGY-APR16					PV	145825	032	00101	30.43	2869/050416
ENERGY-APR16					PV	145825	033	00101	297.55	2869/050416
ENERGY-APR16					PV	145825	034	00101	28.10	2869/050416
ENERGY-APR16					PV	145825	035	00101	5,865.26	2869/050416
ENERGY-APR16					PV	145825	036	00101	1,613.27	2869/050416
ENERGY-APR16					PV	145825	037	00101	4,002.94	2869/050416
ENERGY-APR16					PV	145825	038	00101	1,414.42	2869/050416
ENERGY-APR16					PV	145825	039	00101	1,401.17	2869/050416
ENERGY-APR16					PV	145825	040	00101	1,432.81	2869/050416
ENERGY-APR16					PV	145825	041	00101	2,520.40	2869/050416
ENERGY-APR16					PV	145825	042	00101	9,219.28	2869/050416
ENERGY-APR16					PV	145825	043	00101	2,680.16	2869/050416
ENERGY-APR16					PV	145825	044	00101	3,386.47	2869/050416
ENERGY-APR16					PV	145825	045	00101	238.79	2869/050416
ENERGY-APR16					PV	145825	046	00101	383.38	2869/050416
ENERGY-APR16					PV	145825	047	00101	142.95	2869/050416
ENERGY-APR16					PV	145825	048	00101	40.00	2869/050416
ENERGY-APR16					PV	145825	049	00101	668.25	2869/050416
ENERGY-APR16					PV	145825	050	00101	1,535.89	2869/050416
ENERGY-APR16					PV	145825	051	00101	3,452.58	2869/050416
ENERGY-APR16					PV	145825	052	00101	25.92	2869/050416
ENERGY-APR16					PV	145825	053	00101	29.40	2869/050416
ENERGY-APR16					PV	145825	054	00101	28.10	2869/050416
ENERGY-APR16					PV	145825	055	00101	78.60	2869/050416
ENERGY-APR16					PV	145825	056	00101	29.91	2869/050416
ENERGY-APR16					PV	145825	057	00101	659.47	2869/050416
ENERGY-APR16					PV	145825	058	00101	13.58	2869/050416
ENERGY-APR16					PV	145825	059	00101	13.57	2869/050416
ENERGY-APR16					PV	145825	060	00101	392.98	2869/050416
ENERGY-APR16					PV	145825	061	00101	32.88	2869/050416
ENERGY-APR16					PV	145825	062	00101	361.57	2869/050416
ENERGY-APR16					PV	145825	063	00101	2,158.75	2869/050416

Batch Number - 244869  
Bank Account - 00146807 Cash-General

Payment Number	Payment Date	Address Number	Name	Payment Stub Message	Document Ty	Document Number	Key Item	Key Co	Amount	Invoice Number
72963	05/17/16	2957	SOUTHERN CALIFORNIA EDISON	ENERGY-APR'16	PV	145825	064	00101	1,707.55	2869/050416
				ENERGY-APR'16	PV	145825	065	00101	853.78	2869/050416
				Payment Amount				143,379.08		
				RLV	PV	146024	001	00751	25.42	3293-30/05061
				COMPOST-DL						6
				4/1-5/2/16					25.42	
				Payment Amount						
72964	05/17/16	2958	SOUTHERN CALIFORNIA GAS CO	JBR P/S	PV	145918	001	00101	15.21	1200/050616
				4/5-5/4/16						
				WLK P/S	PV	145919	001	00101	2,660.11	9400/050516
				4/1-5/1/16						
				RLV	PV	146005	001	00751	795.21	4200/051016
				4/7-5/6/16						
				TAPIA	PV	146006	001	00751	560.74	4000/051016
				4/7-5/6/16						
				CORNELL	PV	146007	001	00101	15.21	0400/051016
				4/7-5/6/16						
				HQ&OPS	PV	146025	001	00701	1,092.34	3600/051216
				4/7-5/6/16						
				CONDUIT	PV	146026	001	00101	14.30	8400/051316
				3/24-4/22/16						
				Payment Amount				5,153.12		
72965	05/17/16	16271	SPOK, INC.	PAGER SRV	PV	146023	001	00701	343.25	Z0143084E
				5/10-6/10/16						
				PAGER SRV	PV	146023	002	00701	70.01	Z0143084E
				5/10-6/10/16						
				PAGER SRV	PV	146023	003	00701	42.02	Z0143084E
				5/10-6/10/16						
				Payment Amount				455.28		
72966	05/17/16	2964	STATE BOARD OF EQUALIZATION	SALES/USE TAX-PREPMT	PV	145915	001	00701	2,200.00	97817885/APR1
				APR16						6
				Payment Amount				2,200.00		
72967	05/17/16	3494	WELLS FARGO BANK	REG-GFOA	PV	145916	001	00701	35.00	GFOA2016
				BRKFST						
				SEMN@5/24 DP						
				Payment Amount				35.00		
				Total Amount of Payments Written				214,756.19		
				Total Number of Payments Written				15		

Batch Number - 244875

Bank Account - 00146807 Cash-General

Payment Number	Payment Date	Address Number	Name	Payment Stub Message	Ty	Document Number	Key Item	Key Co	Amount	Invoice Number
72968	05/24/16	20363	JOLIABERGEL	RFND BAL - CLOSED A/C	PV	145861	001	00101	191.37	042681
				Payment Amount					191.37	
72969	05/24/16	16051	ACCURATE TELECOM INC.	PRGRM HQ PHN CNTLR&PGR NOTFCTN	PV	145881	001	00701	450.00	15992
				DID	PV	145971	001	00751	224.57	15972
				LINE@RLV-MPLS MIGRTN	PV	145972	001	00751	227.73	15973
				DID	PV	145973	001	00101	168.39	15974
				LINE@WLK-MPLS MIGRTN	PV	145779	001	00701	78.00	M-0578
72970	05/24/16	2317	ACORN NEWSPAPER	Payment Amount LEGAL AD-NTC OF HRG UWMMP APR'16 DISPLAY ADS APR'16 DISPLAY ADS APR'16 DISPLAY ADS	PV	145817	001	00101	3,103.08	870105/043016
				Payment Amount					1,070.69	
				Payment Amount					5,244.28	
72971	05/24/16	2339	AGOURA LOCK TECHNOLOGIES	CONTROL CYLINDERS	PV	145846	001	00701	294.20	83644
				Payment Amount					294.20	
72972	05/24/16	3077	AIRGAS USA, LLC	10 COOLERS-WHT GLVS, GLASSES & OTHR SAFTY OXYGN&ACETYLN CLS	PV	145748	001	00701	120.12	9050674920
				Payment Amount					817.50	9050627363
				Payment Amount					560.90	9050867114
				Payment Amount					1,498.52	
72973	05/24/16	19993	ALEXANDER'S CONTRACT	MTR READG 4/4-4/28/16	PV	145774	001	00701	14,382.19	100866

Batch Number - 244875

Bank Account - 00145807 Cash-General

Payment Number	Payment Date	Address Number	Name	Payment Stub Message	Ty	Document Number	Key	Item	Co	Amount	Invoice Number
			SERVICES, INC.								
72974	05/24/16	2387	AMERRAY HYDRAULICS CORP	Payment Amount NPPLS,BSHG&EL BWS	PV	145996	001	00701		1,476.76	43785
72975	05/24/16	18955	ARGO CHEMICAL INC.	Payment Amount 6,966 LB AMMONIA	PV	145605	001	00701		1,135.15	1604065
72976	05/24/16	9271	ARMORCAST PRODUCTS CO.	Payment Amount MTR BOXES&LIDS	PV	145997	001	00701		13,539.99	0175341-IN
72977	05/24/16	16224	ASBURY ENVIRONMENTAL SERVICES	Payment Amount RMV OIL&ABSRBT RAGS@WLK	PV	145604	001	00101		200.14	1500-00023655
72978	05/24/16	5625	ASSOC. OF WATER AGENCIES OF VENTURA CO	Payment Amount OP TECH WRKSHIP 4/21/16	PV	145793	001	00701		850.00	06-8956
72979	05/24/16	2407	ATLAS TOWING	REG-WTR SYMPOSIUM 4/21/16	PV	145794	001	00701		820.00	06-8946
72980	05/24/16	7965	B&B PALLET CO.	Payment Amount JUMP START VEH#112 55 YDS WOOD CHIPS 55 YDS WOOD CHIPS 55 YDS WOOD CHIPS 55 YDS WOOD CHIPS 55 YDS WOOD CHIPS	PV	145880	001	00701		87.50	53816
				Payment Amount 55 YDS WOOD CHIPS 55 YDS WOOD CHIPS 55 YDS WOOD CHIPS 55 YDS WOOD CHIPS 55 YDS WOOD CHIPS	PV	145764	001	00701		638.00	114904
				55 YDS WOOD CHIPS	PV	145765	001	00701		638.00	114905
				55 YDS WOOD CHIPS	PV	145766	001	00701		638.00	114906
				55 YDS WOOD CHIPS	PV	145767	001	00701		638.00	114927
				55 YDS WOOD CHIPS	PV	145768	001	00701		638.00	114928
				55 YDS WOOD CHIPS	PV	145769	001	00701		638.00	114929
				55 YDS WOOD CHIPS	PV	145984	001	00701		638.00	115180

Batch Number - 244875  
Bank Account - 00146807 Cash-General

Payment Number	Date	Address Number	Name	Payment Stub Message	Ty	Document Number	Key Item	Co	Amount	Invoice Number
				CHIPS						
				55 YDS WOOD	PV	145985	001	00701	638.00	115181
				CHIPS						
				55 YDS WOOD	PV	145986	001	00701	638.00	115182
				CHIPS						
				55 YDS WOOD	PV	145987	001	00701	638.00	115183
				CHIPS						
				55 YDS WOOD	PV	145988	001	00701	638.00	115184
				CHIPS						
				55 YDS WOOD	PV	145989	001	00701	638.00	115189
				CHIPS						
				Payment Amount					7,656.00	
72981	05/24/16	20372	TYLER BARKS	RFND BAL -	PV	145951	001	00101	8.11	072265
				CLOSED A/C						
				Payment Amount					8.11	
72982	05/24/16	18693	BILLTRUST	4/16 ONLN	PV	145839	001	00701	6,787.24	144813
				BILLG&PMT						
				MDFY ONLN	PV	145961	001	00701	1,200.00	145005
				BILLG OPTION						
				Payment Amount					7,987.24	
72983	05/24/16	20373	BONAD LLC	RFND BAL -	PV	145952	001	00101	861.19	9998612
				CLOSED A/C						
				Payment Amount					861.19	
72984	05/24/16	20370	DAVID BRONSON	TURF RMVL	PV	145914	001	00101	1,620.00	2160250
				REBATE						
				Payment Amount					1,620.00	
72985	05/24/16	18739	CALIFORNIA HAZARDOUS SERVICES, INC.	MAY'16 OP SITE VISIT	PV	145751	001	00701	105.00	58886
				Payment Amount					105.00	
72986	05/24/16	2513	CAPCO ANALYTICAL SERVICES	APR'16 DGSTR TSTG	PV	145746	001	00701	577.50	160712
				Payment Amount					577.50	
				APR'16 DGSTR TSTG	PV	145747	001	00751	7.50	160712
				Payment Amount					7.50	
72987	05/24/16	18692	CDW GOVERNMENT	2 VEH MOUNTS	PV	145744	001	00701	893.80	CVL6724
				Payment Amount					893.80	



Batch Number - 244875  
Bank Account - 00146807 Cash-General

Payment Number	Payment Date	Address Number	Name	Payment Stub Message	Ty	Document Number	Key Item Co	Amount	Invoice Number
75 REMITTANCE DR., SUITE 1515 CHICAGO IL 60675-1515									
72988	05/24/16	18860	CHEMTREAT, INC.	Payment Amount MAY'16 WTR TRWT	PV	145991	001 00701	893.80 562.71	2230933
72989	05/24/16	2536	CITY OF LOS ANGELES	Payment Amount SWG CHG 15/16 O&M-6TH INSTLMT	PV	145829	001 00130	26,039.00	74WP160000023 /6
72990	05/24/16	2541	CITY OF WESTLAKE VILLAGE	Payment Amount PRMT-EMGCY LK RPR@3 SPRNGS DR	PV	145834	001 00101	39,408.00 195.00	74WP160000024 /6 15/16-058
72991	05/24/16	20327	CLIMATEC, LLC	Payment Amount HQ CHILLR SVC	PV	145932	001 00701	195.00 1,125.00	15/16-059 LV35219
72992	05/24/16	6873	JANICE C. COHEN	Payment Amount RFND BAL - CLOSED A/C	PV	145859	001 00101	59.61	020393
72993	05/24/16	20374	SEAN LINALE COLLINS	Payment Amount RFND BAL - CLOSED A/C	PV	145953	001 00101	59.61 115.02	068712
72994	05/24/16	19305	COMMERCIAL CLEANING SYSTEMS	Payment Amount MAY'16 CLEANING SVC	PV	145750	001 00701	115.02 3,525.68	322197
72995	05/24/16	20364	THEODORE CONNORS	Payment Amount RFND BAL - CLOSED A/C	PV	145750	003 00701	464.30	322197
72996	05/24/16	4586	CONSOLIDATED ELECTRICAL DISTRIBUTORS	Payment Amount RFND BAL - CLOSED A/C CNDT SEAL&EX PRF JWJ	PV	145862	001 00101	1,640.98 336.84 138.67	322197 013928 9009-731949

Batch Number - 244875  
Bank Account - 00146807 Cash-General

Payment Number	Payment Date	Address Number	Name	Payment Stub Message	Document		Key		Amount	Invoice Number
					Ty	Number	Lim	Co		
				DISCOUNT-CNDT	PD	145934	001	00751	1.59	9009-731949
				SEAL&EX PRF						
				JWL						
				Payment Amount				137.08		
72997	05/24/16	2547	COUNTY	4/19 TAPIA	PV	146039	001	00701	241.81	48892/043016
			SANITATION	RAGS DISP						
			DISTRICTS OF							
			LA COUNTY							
				4/5 LIFT STN	PV	146040	001	00130	234.23	48892/043016
				DISP						
				Payment Amount				476.04		
72998	05/24/16	20375	ANNA R. COX	RFND BAL -	PV	145954	001	00101	26.62	056700
				CLOSED A/C						
				Payment Amount				26.62		
72999	05/24/16	17206	DC FROST ASSOCIATES, INC.	COMPACTR	PV	145852	001	00701	19,597.11	9938
				SCREWS&BEARG						
				FREIGHT	PV	145852	005	00701	354.88	9938
				Payment Amount				19,951.99		
73000	05/24/16	20378	MARIA DEL RAMIREZ	RFND BAL -	PV	145957	001	00101	30.48	039056
				CLOSED A/C						
				Payment Amount				30.48		
73001	05/24/16	2601	DELL COMPUTER CORP	4- 24"	PV	145907	001	00701	577.56	XJX8XCKT2
				MONITORS						
				ENVIRO	PV	145907	002	00701	66.37	XJX8XCKT2
				FEE/TAX						
				Alt Payee						
			7819 DELL MARKETING LP							
			P.O. BOX 910916							
			PASADENA CA 91110-0916							
			Payment Amount					643.93		
73002	05/24/16	20313	DXP ENTERPRISES, INC.	SNDPR	PV	145980	001	00701	4,446.64	8608940
				SUCTN&DCHG						
				MANIFLD						
				RTN	PV	145981	001	00701	3,759.28	8600206
				SUCTN&DCHG						
				MANIFLD						
				SNDPR SUCTN	PV	145982	001	00701	1,041.99	8658982
				MANIFLD						
				SHIPPING CR	PD	145983	001	00101	366.21	8773097
				ON RTN						

Batch Number - 244875

Bank Account - 00145807 Cash-General

Payment Number	Payment Date	Address Number	Name	Payment Stub Message	Ty	Document Number	Key Item Co	Amount	Invoice Number
73003	05/24/16	20340	MARK EGAN	Payment Amount RFND BAL - CLOSED A/C	PV	145948	001 00101	136.09	1150862-05895 8
73004	05/24/16	18111	ELECSYS INTERNATIONAL CORPORATION	Payment Amount JUNE'16 RADIX MAINT	PV	145773	001 00701	261.00	149401
73005	05/24/16	18441	EMPLOYEE RELATIONS NETWORK	Payment Amount BCKGRND CHKS-D.R & C.O.	PV	145970	001 00701	266.95	74859
73006	05/24/16	20365	F I G HOLDING CO.	Payment Amount RFND BAL - CLOSED A/C RFND BAL - CLOSED A/C RFND BAL - CLOSED A/C	PV	145863	001 00101	433.18	047711
73007	05/24/16	2654	FAMCON PIPE	Payment Amount FORD MTR BX PRTS&FTGS CPLG,NPL,PLG& AIR VACS VNDL RD PSSR RDCG STN PARTS	PV	145753	001 00701	6,008.85	179831
73008	05/24/16	18815	FASTENAL COMPANY	Payment Amount 8" DI FLG TEE FLNG.SHEETG&T APE RESTOCK BOLT BINS	PV	145780	001 00701	1,078.02	179921
				Payment Amount FASTENAL COMPANY	PV	145742	001 00701	818.72	CACHA21675
			Alt Payee 18835 FASTENAL COMPANY P. O. BOX 1286 WINONA MN 55987-1286						
73009	05/24/16	20362	FIERCE FIRE PROTECTION, INC.	Payment Amount FIRE FLW TST-HYD@TAPIA	PV	145850	001 00751	300.00	16-0330FF
				Payment Amount				300.00	

Batch Number - 244875  
Bank Account - 00146807 Cash-General

Payment Number	Payment Date	Address Number	Name	Payment Stub Message	Document Ty	Document Number	Key Item	Key Co	Amount	Invoice Number
73010	05/24/16	19397	FIRST CHOICE SERVICES	HO COFFEE	PV	145937	001	00701	95.43	223425
				SUPPLIES						
				OPS COFFEE	PV	145938	001	00701	95.29	223426
				SUPPLIES						
				RLV COFFEE	PV	145939	001	00701	63.60	223427
				SUPPLIES						
				TAPIA COFFEE	PV	145940	001	00701	69.09	223428
				SUPPLIES						
				Payment Amount				323.41		
73011	05/24/16	2660	FISHER SCIENTIFIC	NYL FILTRS	PV	145863	001	00701	102.65	2229493
				0.22 UM						
			All Payee							
			3202 FISHER SCIENTIFIC							
			FILE #50129							
			LOS ANGELES CA 90074-0129							
				Payment Amount				102.65		
73012	05/24/16	2661	FLO-SYSTEMS INC	LIFT STN PUMP	PV	145806	001	00701	12,100.09	F158866-16B061
				PARTS						
				LIFT STN PUMP	PV	145806	008	00701	137.39	F158866-16B061
				PARTS						
				Payment Amount				12,237.48		
73013	05/24/16	4971	FUGRO CONSULTANTS, INC.	3/25-4/21/16	PV	146027	001	00701	6,190.81	04.62160017-1
				GEOTCH MNTRG						
			All Payee							
			6803 FUGRO CONSULTANTS, INC.							
			P. O. BOX 301083							
			DALLAS TX 75303-1083							
				Payment Amount				6,190.81		
73014	05/24/16	19045	JAMIE GARCIA	RFND BAL -	PV	145860	001	00101	76.57	056963
				CLOSED A/C						
				Payment Amount				76.57		
73015	05/24/16	18126	GARDENERD	VEG GARDNG	PV	145879	001	00101	515.12	2202
				CLASS@5/4/16						
				Payment Amount				515.12		
73016	05/24/16	20366	EVANGELINA GARRETT	RFND BAL -	PV	145866	001	00101	19.38	046606
				CLOSED A/C						
				Payment Amount				19.38		
73017	05/24/16	2691	GIERLICH-MITC HELL, INC.	SPRKT&BEARIN	PV	145807	001	00701	5,325.96	GC14645
				GS						
				Payment Amount				5,325.96		
				FREIGHT	PV	145807	003	00701	151.51	GC14645
			All Payee							



Batch Number - 244875  
Bank Account - 00146807 Cash-General

Payment Number	Payment Date	Address Number	Name	Payment Stub Message	Ty	Document Number	Key Item	Co	Amount	Invoice Number
			LLC							
73025	05/24/16	16543	INTERNATIONAL INSTITUTE OF MUNI CLERKS	APR'16 RCRDS MGMT Payment Amount	PV	145771	001	00701	4,160.00	LVMWD-201604
				MRRSHF FY16-17	PV	145964	001	00701	120.00	27942/FY16-17
				J.BODENHAMER Payment Amount					120.00	
73026	05/24/16	4144	INTERSTATE BATTERY SYSTEMS	VEH#112&877 BATTERIES	PV	145990	001	00701	255.10	51041979
				Payment Amount					255.10	
73027	05/24/16	3083	JCI JONES CHEMICALS, INC	4,274 GAL BISULFITE	PV	145686	001	00701	5,684.42	686639
				Payment Amount					5,684.42	
				JCI JONES CHEMICALS, INC P.O. BOX 636877 CINCINNATI OH 45263-6877						
73028	05/24/16	4860	JWC ENVIRONMENTAL	MUFFIN MNSTR GRNDR	PV	145745	001	00701	9,104.77	80662
				Payment Amount					9,104.77	
73029	05/24/16	2752	KAMAN INDUSTRIAL TECHNOLOGIES	2 FINSHD BORE VS SHEAVE	PV	145906	001	00701	114.88	Y447516
				Payment Amount					114.88	
73030	05/24/16	12260	KATZ & ASSOCIATES, INC.	2/1-3/31/16 SEAS STRG PRJCT	PV	145772	001	00701	11,933.93	411043
				Payment Amount					11,933.93	
73031	05/24/16	5230	KENNEDY/JENKS CONSULTANTS	P/E 4/29/16 2015 UWMP	PV	145851	001	00701	9,608.40	101242
				Payment Amount					9,608.40	
73032	05/24/16	19777	L&J TECHNOLOGIES COMPANY	ELEC DRIP TRAP	PV	145992	001	00701	3,662.20	148449
				Payment Amount					3,662.20	
73033	05/24/16	3352	LAS VIRGENES MUNICIPAL WATER	REV-BLDG#8 RW 3/29-4/27/16	PV	145930	001	00701	132.22	2652/051116
				Payment Amount					132.22	

Batch Number - 244875  
Bank Account - 00146807 Cash-General

Payment Number	Payment Date	Address Number	Name	Payment Stub Message	Ty	Document Number	Lim	Co	Key	Amount	Invoice Number	
DISTRICT												
73034	05/24/16	20376	WYANT LAUTERMAN	JED SMITH P/S 4/6-5/5/16 Payment Amount	PV	145931	001	00101		29.47	0254/051116	
				RFND BAL - CLOSED A/C Payment Amount	PV	145955	001	00101		891.20	9997787	
73035	05/24/16	3164	LEMIEUX & O'NEILL	RETAINER-APR' 16 PROF SRV-APR'16 PROF SRV-APR'16 PROF SRV-APR'16 Payment Amount	PV	145842	001	00701		7,000.00	140-999M/0416	
				MILEAGE-ACWA WTRMISE 3/17/16 MILEAGE-ACWA WTR SYMP 4/21/16 Payment Amount	PV	145776	001	00701		29.05	031716	
73036	05/24/16	19396	JAY LEWITT		PV	145777	001	00701		29.05	042116	
73037	05/24/16	3483	DAVID LIPPMAN	CELL PHN EXP 3/4-4/3/16 EXP-CASA FRSHWTR TRUSTCNF 4/14 RFND-OJP MEAL TIP 4/26/16 Payment Amount	PV	145778	001	00701		92.35	7898/040316	
				APR'16 COMPOST ADS LEGAL ADS 4/14&4/21/16 LEGALAD-18" REW JNT BNDG RPR Payment Amount	PV	145783	001	00701		35.07	041416	
73038	05/24/16	2590	LOS ANGELES DAILY NEWS		PD	145784	001	00701		1.47-	042616	
				TRFFC RPT#916-02138 Payment Amount	PV	145821	001	00751		1,055.00	0000269315	
73039	05/24/16	5698	LOST HILLS/MALIBU		PV	145822	001	00701		874.60	0010790620	
					PV	145849	001	00701		1,261.60	0010791550	
				Payment Amount	PV	145831	001	00101		25.00	916-02138-222	

Batch Number - 244875

Bank Account - 00146807 Cash-General

Payment Number	Payment Date	Address Number	Name	Payment Stub Message	Document Ty	Document Number	Key Item	Key Co	Amount	Invoice Number
			SHERIFF'S STATION			-2224				
				Payment Amount					25.00	
73040	05/24/16	20377	RICHARD LUTHER	RFND BAL - CLOSED A/C	PV	145956	001	00101	4.72	044947
				Payment Amount					4.72	
73041	05/24/16	17295	MAILFINANCE	5/9-6/8/16 PSTG MCHN	PV	146031	001	00701	221.98	N5921945
				Payment Amount					221.98	
73042	05/24/16	2814	MCMMASTER-CARR SUPPLY CO	SS TUBING&FITTING GS	PV	145841	001	00751	401.01	56651412
				Payment Amount					401.01	
			Alt Payee							
			3197 MC MASTER-CARR							
			P. O. BOX 7690							
			CHICAGO IL 60680-7690							
				Payment Amount					401.01	
73043	05/24/16	19026	MNS ENGINEERS, INC.	8/25/15-3/5/16 6 CHNL MXG IMPRV	PV	145808	001	00701	979.87	66936
				Payment Amount					979.87	
73044	05/24/16	18940	MP PRINTING & MAILING	PREPMT-PSTG WTR QLTY RPT	PV	145775	001	00101	6,929.00	61013
				Payment Amount					6,929.00	
73045	05/24/16	2365	MSO TECHNOLOGIES	2/1-3/31/16 W/LK P/S UPGRD	PV	145715	001	00701	1,750.00	5205
				Payment Amount					1,750.00	
				2/1-3/31/16 W/LFP EXPSN	PV	145716	001	00701	1,750.00	5205
				Payment Amount					1,750.00	
				MAR'16 PLC&DO TSTG	PV	145819	001	00701	4,060.00	5223
				Payment Amount					4,060.00	
73046	05/24/16	8065	MWH AMERICAS, INC	RW STRG STD-DSN 3/16	PV	145888	001	00701	40,790.50	1711141
				Payment Amount					40,790.50	
				RW ENCINO RSV STD 3/16	PV	145889	001	00701	7,192.00	1711141.1
				Payment Amount					7,192.00	
73047	05/24/16	2842	NAPA AUTO PARTS	VEH#880&709 DIESL FLD	PV	145877	001	00701	29.41	813193
				Payment Amount					29.41	
73048	05/24/16	2302	OFFICE DEPOT	MISC OFFICE SUPPLIES	PV	146034	001	00701	222.60	835988375001
				Payment Amount					222.60	



Batch Number - 244875

Bank Account - 00146807 Cash-General

Payment Number	Payment Date	Address Number	Name	Payment Stub Message	Ty	Document Number	Key	Amount	Invoice Number
							itm Co		
73049	05/24/16	16372	OLIN CORPORATION - CHLOR ALKALI	EXPO MARKERS	PV	146035	001 00701	6.97	835988495001
				PHONE CLN	PV	146036	001 00701	50.62	837460952001
				PADS					
				LABLR, FILES, NAMETAG	PV	146037	001 00701	578.48	837460051001
				RUBBERBANDS	PV	146038	001 00701	24.61	837460148001
				Payment Amount			883.28		
				4,900 GAL	PV	145781	001 00701	2,671.55	2157269
				HYPOCHLORITE					
				4,956 GAL	PV	145856	001 00701	2,702.08	2161171
				HYPOCHLORITE					
				OLIN CORPORATION - CHLOR ALKALI					
				P.O. BOX 402766					
				ATLANTA GA 30384-2766					
73050	05/24/16	20368	MARTIN OLSON	RFND BAL -	PV	145888	001 00101	314.77	042579
				CLOSED A/C					
				Payment Amount			5,373.63		
73051	05/24/16	15824	OUTBACK FOOTWEAR	PRTCTV	PV	145926	001 00701	225.00	27708
				FTWR-S. BAIRD					
				Payment Amount			314.77		
73052	05/24/16	18946	PACIFIC ADVANCED CIVIL ENGINEERING, INC.	APR'16 SLDG WET WELL	PV	145820	001 00701	5,316.00	98035
				Payment Amount			225.00		
73053	05/24/16	18874	PACIFIC HYDROTECH CORPORATION	PMT#2-WLK P/S UPGRD	PV	145962	001 00701	29,650.00	10558/#2
				5%	PD	145963	001 00301	1,482.50-	10558/RTN#2
				RETENTION-PIE					
				5/5/16					
				Payment Amount			28,167.50		
73054	05/24/16	17860	SHERRI PANIAGUA	EXP-IPMA-HR CONF	PV	146021	001 00701	260.72	042916
				4/26--4/29/16					
				MILEAGE-CALPE	PV	146022	001 00701	68.90	050616
				LRA MTG					

Batch Number - 244875

Bank Account - 00146807 Cash-General

Payment Number	Payment Date	Address Number	Name	Payment Stub Message	Ty	Document Number	Key ltn Co	Amount	Invoice Number
73055	05/24/16	19164	DONALD PATTERSON	Payment Amount CELL PHN EXP 1/29-4/28/16	PV	145965	001 00701	329.62 255.97	CELL/FEB-APR1 8
73056	05/24/16	3481	DEBORAH PETERS	Payment Amount PW QTLY TOUR-LNCH TRAYS@5/14	PV	146020	001 00101	255.97 152.96	051416
73057	05/24/16	18084	PHOENIX CIVIL ENGINEERING, INC.	Payment Amount P/E 4/30/16 TWN LKS DRNG	PV	145993	001 00701	152.96 310.00	PHOE16-138
73058	05/24/16	8484	PRAXAIR DISTRIBUTION, INC	Payment Amount 4 AIR BOTTLES	PV	145791	001 00101	310.00 128.14	55145917
73059	05/24/16	20334	PRUDENTIAL OVERALL SUPPLY	Payment Amount 4/16 UNIFRMS,MATS/ TWLS@TAPIA 4/16 UNIFRMS,MATS/ TWLS@TAPIA 4/16 UNIFRMS,MATS/ TWLS@TAPIA 4/16 UNIFRMS,MATS/ TWLS@TAPIA 4/16 UNIFRMS,MATS/ TWLS@TAPIA 4/16 UNIFRMS,MATS/ TWLS@TAPIA	PV	145890	001 00701	482.59 52.70 54.31 56.10 54.31 53.60 54.31	550887637 55103753 170666143 170666143 170667715 170667715 170670121 170670121

Batch Number - 244875

Bank Account - 00146807 Cash-General

Payment Number	Date	Address Number	Name	Payment Stub Message	Ty	Document . . . Number	Key itm Co	Amount	Invoice Number
				TWLS@TAPIA					
	4/16			UNIFRMS,MATS/	PV	145893	001 00701	57.40	170671679
				TWLS@TAPIA					
	4/16			UNIFRMS,MATS/	PV	145893	002 00701	54.31	170671679
				TWLS@TAPIA					
	4/16			UNIFRMS,MATS/	PV	145894	001 00701	15.20	170666144
				TWLS@WLK					
	4/16			UNIFRMS,MATS/	PV	145894	002 00701	20.36	170666144
				TWLS@WLK					
	4/16			UNIFRMS,MATS/	PV	145895	001 00701	15.20	170667714
				TWLS@WLK					
	4/16			UNIFRMS,MATS/	PV	145895	002 00701	20.36	170667714
				TWLS@WLK					
	4/16			UNIFRMS,MATS/	PV	145896	001 00701	15.20	170670118
				TWLS@WLK					
	4/16			UNIFRMS,MATS/	PV	145896	002 00701	21.44	170670118
				TWLS@WLK					
	4/16			UNIFRMS,MATS/	PV	145897	001 00701	15.20	170671676
				TWLS@WLK					
	4/16			UNIFRMS,MATS/	PV	145897	002 00701	21.44	170671676
				TWLS@WLK					
	4/16			UNIFRMS,MATS/	PV	145898	001 00701	229.28	170666141
				TWLS@HQ					
	4/16			UNIFRMS,MATS/	PV	145899	001 00701	234.33	170667716
				TWLS@HQ					
	4/16			UNIFRMS,MATS/	PV	145900	001 00701	235.93	170670119
				TWLS@HQ					
	4/16			UNIFRMS,MATS/	PV	145901	001 00701	238.68	170671677
				TWLS@HQ					

Batch Number - 244875

Bank Account - 00146807 Cash-General

Payment Number	Date	Address Number	Name	Payment Stub Message	Document Ty	Item	Key Co	Amount	Invoice Number
				UNIFRMS,MATS/ TWLS@HQ					
				4/16	PV	145902 001	00701	24.00	170666142
				UNIFRMS,MATS/ TWLS@RLV					
				4/16	PV	145902 002	00701	30.83	170666142
				UNIFRMS,MATS/ TWLS@RLV					
				4/16	PV	145903 001	00701	24.00	170667713
				UNIFRMS,MATS/ TWLS@RLV					
				4/16	PV	145903 002	00701	30.83	170667713
				UNIFRMS,MATS/ TWLS@RLV					
				4/16	PV	145904 001	00701	24.00	170670120
				UNIFRMS,MATS/ TWLS@RLV					
				4/16	PV	145904 002	00701	29.03	170670120
				UNIFRMS,MATS/ TWLS@RLV					
				4/16	PV	145905 001	00701	24.00	170671678
				UNIFRMS,MATS/ TWLS@RLV					
				4/16	PV	145905 002	00701	29.03	170671678
				UNIFRMS,MATS/ TWLS@RLV					
				Payment Amount				1,735.38	
73060	05/24/16	13645	PSOMAS	MAR'16 STNDBY	PV	145789 001	00701	786.25	117682
				CHG&DEF PRGM					
				MAR'16 STNDBY	PV	145796 001	00701	40.00	117681
				CHG SRV					
				Payment Amount				826.25	
73061	05/24/16	2585	PURETEC	5/1-7/31/16	PV	145994 001	00701	225.00	1480207
				14" DI RNTL					
				5/1-7/31/16	PV	145995 001	00701	71.58	1480415
				8" DI RNTL					
				Payment Amount				296.58	
73062	05/24/16	16788	RADIO ACTIVITY	SCADA TRNSCVR	PV	145828 001	00101	1,120.00	0050616
				TSTG@6 LOCTNS					
				SCADA	PV	145887 001	00101	275.00	0051116
				TRANSCVR SVC					

Batch Number - 244875

Bank Account - 00146807 Cash-General

Payment Number	Payment Date	Address Number	Name	Payment Stub Message	Ty	Document Number	Key	Item	Co	Amount	Invoice Number
73063	05/24/16	20379	MITCHELL ROBE	Payment Amount RFND BAL - CLOSED A/C	PV	145958	001	00101		1,395.00 13.87	070077
73064	05/24/16	17174	ROTH STAFFING COMPANIES, LP	Payment Amount 4/25-4/29/16 E.M.AGUILAR	PV	145855	001	00701		799.20 799.20	13275087 13278047
73065	05/24/16	19832	NADINE ROTHERMEL	Payment Amount RFND BAL - CLOSED A/C	PV	145947	001	00101		1,598.40 67.81	054413
73066	05/24/16	20380	JASON RYAN	Payment Amount RFND BAL - CLOSED A/C	PV	145959	001	00101		56.48	067595
73067	05/24/16	20371	BRIAN SAKO	Payment Amount TURF RMVL REBATE	PV	145968	001	00101		1,884.00	500440
73068	05/24/16	20381	ALEJANDRA SANCHEZ	Payment Amount RFND BAL - CLOSED A/C	PV	145960	001	00101		1,884.00 98.16	067881
73069	05/24/16	6940	SECTRAN SECURITY, INC.	Payment Amount MAY'16 COURIER SVC	PV	146030	001	00701		296.40	16050643
73070	05/24/16	19688	SELLECK DEVELOPMENT GROUP, INC.	Payment Amount RFND BAL - CLOSED A/C	PV	145946	001	00101		296.40 232.81	052587
73071	05/24/16	8228	SEMELE GROUP, INC.	Payment Amount MAIN EXT REIMB AGRMT	PV	198550	001	00701		12,955.55 232.81	4472-028-028
73072	05/24/16	20193	SIMI VALLEY TIRE PROS	Payment Amount VEH#163 FLAT TIRE RPR	PV	145882	001	00701		12,955.55 195.00	1008867
73073	05/24/16	8752	SIMPLEXGRINNE LL LP	Payment Amount RLV FIRE ALARM SYS RPR	PV	145803	001	00751		1,001.00	82017142
73074	05/24/16	19169	SJM INDUSTRIAL RADIO	Payment Amount REPEATR LOANR@TAPIA	PV	145911	001	00751		1,001.00 150.00	38101

Batch Number - 244875

Bank Account - 00146807 Cash-General

Payment Number	Payment Date	Address Number	Name	Payment Stub Message	Ty	Document Number	Key ltm	Key Co	Amount	Invoice Number
73075	05/24/16	2945	SKAUG TRUCK BODY WORKS	Payment Amount VEH#174 TRCK BED&SIDE GATES	PV	145878	001	00701	150.00 2,693.63	37264
73076	05/24/16	20383	KAREN SOBEL	Payment Amount TURF RMVL REBATE	PV	145969	001	00101	1,076.00	230158
73077	05/24/16	19141	SOLARWINDS, INC.	Payment Amount ANNL MAINT-SLRWINDS WEB HELP	PV	145838	001	00701	1,076.00 640.00	IN273850
73078	05/24/16	3543	HOWARD SOMBERG	Payment Amount TURF RMVL REBATE	PV	145967	001	00101	3,374.00	250202
73079	05/24/16	2956	SOUTH COAST AIR QUALITY MGMT DIST	Payment Amount HOT SPOTS FEE-RLV#94009	PV	146014	001	00751	122.53 3,374.00	2946111
				HOT SPOTS FEE-TP #20457	PV	146015	001	00751	122.53	2944811
				HOT SPOTS FEE-WLK #54773	PV	146016	001	00101	122.53	2945222
				HOT SPOTS FEE-US#1 #63250	PV	146017	001	00130	122.53	2945287
				HOT SPOTS FEE-US#2 #66254	PV	146018	001	00130	122.53	2945371
				HOT SPOTS FEE-OPS #30439	PV	146019	001	00701	122.53	2944948
73080	05/24/16	19379	ANDREW SPEAR	Payment Amount MILEAGE/MEAL- LCW WKSHIP 5/4/16	PV	145913	001	00701	735.18 74.64	050416
73081	05/24/16	8212	STANSBERRY'S WELDING	Payment Amount WELDING 3" SPOOLS	PV	145912	001	00101	405.00	2146
73082	05/24/16	3789	T & T TRUCK &	Payment Amount 40-TN HYD	PV	145797	001	00701	405.00 1,170.00	0125613-IN

Batch Number - 244875

Bank Account - 00146807 Cash-General

Payment Number	Payment Date	Address Number	Name	Payment Stub Message	Ty	Document Number	Key Item	Co	Amount	Invoice Number
73083	05/24/16	19681	THE PUN GROUP, LLP	CRANE@RLV Payment Amount 4/16 AUDIT-LV YE 6/30/16	PV	145840	001	00701	15,000.00	1600113
73084	05/24/16	9505	TIRE MAN AGOURA	Payment Amount VEH#714 (4) NEW TIRES VEH#325 PRSSR MONTRG SNSR	PV	145870	001	00701	960.13	2051792
73085	05/24/16	18651	TOYOTA-LIFT OF LOS ANGELES	Payment Amount VEH#305 SVC&RPRS	PV	145790	001	00701	316.07	WO-347348
73086	05/24/16	19135	TRANSUNION RISK & ALTERNATIVE DATA SOLUT	Payment Amount VEH#202 P/M SVC VEH#134 P/M SVC VEH#723 P/M SVC	PV	145884	001	00701	113.70	WO-344454
73087	05/24/16	3006	UNDERGROUND SERVICE ALERT	Payment Amount ONLN SRCH BAD DBT 4/16	PV	145792	001	00701	123.00	97457/APR16
73088	05/24/16	16810	UNIFIRST CORPORATION	Payment Amount 166 NEW TICKET CHGS Payment Amount UNIFORM SRV-FINAL PMT	PV	145837	001	00701	249.00	420160411
73089	05/24/16	20369	BRANDI VALDEZ	Payment Amount RFND BAL - CLOSED A/C	PV	145869	001	00101	271.88	054866
73090	05/24/16	7370	VALIN CORPORATION	Payment Amount POLPROPYLEN FILTR Payment Amount 2 ADS DSPLY@4/28/16	PV	145857	001	00701	1,581.38	3134333
73091	05/24/16	2780	VALLEY NEWS GROUP	Payment Amount 2 ADS DSPLY@4/28/16	PV	145795	001	00101	460.00	4-28
				Payment Amount 2 ADS DSPLY@4/28/16	PV	145795	002	00101	110.00	4-28

Batch Number - 244875  
Bank Account - 00145807 Cash-General

Payment Number	Payment Date	Address Number	Name	Payment Subj. Message	Document Ty	Document Number	Key Item	Key Co	Amount	Invoice Number
73092	05/24/16	18923	VAULT ACCESS SOLUTIONS	DISPLAY AD@5/5-RAIN BRLS Payment Amount VAULT LIDS	PV	145929	001	00101	460.00	5-5
									1,030.00	
									28,470.00	223
73093	05/24/16	16623	VELOCITY TECHNOLOGY SOLUTIONS, INC.	Payment Amount JUN'16 DISASTR RECVRY	PV	146041	001	00701	3,114.00	313005
									3,114.00	
73094	05/24/16	13326	VILLA ESPERANZA SERVICES	Payment Amount APR'16 LANDSCAPE SRV	PV	145818	001	00701	1,293.71	LVMWD 2016-5
									3,592.51	LVMWD 2016-5
									663.78	LVMWD 2016-5
73095	05/24/16	2436	VINCE BARNES AUTOMOTIVE	Payment Amount VEH#147 OIL/FLTRS, TRANS COOLR VEH#900 OIL/FLTRS VEH#138 BRK PDS,EXHST ASSEMBLY VEH#878 SPRK PLGS,SERP BLT&OIL VEH#716 LGHT BR&AIR CMPRSSR	PV	145872	001	00701	191.23	021495
									5,550.00	
									103.28	021492
									1,076.12	021481
									434.75	021484
									991.63	021446
73096	05/24/16	3035	VWR SCIENTIFIC	Payment Amount LAB SUPPLIES	PV	145836	001	00701	1,002.73	8044796132
									2,797.01	
									73.43	8044796132

All Payee 3216 VWR INTERNATIONAL, INC  
P. O. BOX 640169



Batch Number - 244875  
Bank Account - 00146807 Cash-General

Payment Number	Payment Date	Address Number	Name	Payment Stub Message	Ty	Document Number	Key Item	Key Co	Amount	Invoice Number
PITTSBURGH PA 15264-0169										
73097	05/24/16	19885	W. LITTEN INC.	PaymentAmount VICTAULC PIPE TO 2ND CASTLE	PV	145683	001	00701	195.30	11080
				SRV 4/24-4/30/16@ RLV	PV	145941	001	00701	5,180.60	11079
				SRV 5/1-5/7/16@RL V	PV	145942	001	00701	4,542.60	11081
73098	05/24/16	16914	WECK LABORATORIES, INC.	PaymentAmount LAB SRV@TAPIA EFFL GRB	PV	145786	001	00701	217.00	W6D1791-LV
				LAB SRV@TAPIA EFFL	PV	145787	001	00701	500.00	W6D1762-LV
				COMPOSITE LAB SRV@TAPIA INFLNT	PV	145788	001	00701	272.00	W6D1764-LV
				LAB SRV@MALIBU CREEK	PV	145798	001	00701	4,592.00	W6D1767-LV
				LAB SRV@TAPIA PRCSS CTL	PV	145908	001	00701	195.00	W6E0145-LV
				LAB SRV@TAPIA PRCSS CTL	PV	145909	001	00701	195.00	W6E0146-LV
				LAB SRV@MC-DIAZIN ON	PV	145910	001	00701	960.00	W6E0135-LV
73099	05/24/16	3047	WESCO DISTRIBUTION, INC.	PaymentAmount PLUG MOLDS&END FTGS	PV	146029	001	00701	195.00	W6E0570-LV
				Alt Payee					7,126.00	
				6443 WESCO DISTRIBUTION, INC PO BOX 31001-0465 PASADENA CA 91110-0465	PV	145654	001	00701	214.67	548431
73100	05/24/16	20347	WH AGOURA 24	PaymentAmount RFND BAL -	PV	145949	001	00101	1,509.64	9997887

Batch Number - 244875

Bank Account - 00146807 Cash-General

Payment Number	Payment Date	Address Number	Name	Payment Stub Message	Ty	Document Number	Key	Item	Co	Amount	Invoice Number
			LP	CLOSED A/C							
73101	05/24/16	3507	WORDLAND	Payment Amount ANNL PRINTER MAINT	PV	145752	001 00701	001	00701	4,200.00	56267
73102	05/24/16	8510	WORK BOOT WAREHOUSE	Payment Amount PRTCTV FTWR-S.JACKSO N	PV	145927	001 00701	001	00701	175.60	2-23906
73103	05/24/16	20361	PAULINE YIK	Payment Amount TURF RMVL REBATE	PV	145833	001 00101	001	00101	1,760.00	660482
73104	05/24/16	19654	GIL ZAHAVI	Payment Amount RFND BAL - CLOSED A/C INTEREST	PV	145944	001 00101	001	00101	1,204.54	9997552
73105	05/24/16	6248	ZENNER PERFORMANCE METERS, INC.	Payment Amount 2" IRRIG METERS	PV	145945	001 00101	001	00101	.62	9997552/INT
				Payment Amount	PV	145858	001 00701	001	00701	1,179.74	0031587-IN
Total Amount of Payments Written										1,179.74	
Total Number of Payments Written										499,244.40	
										138	



**LAS VIRGENES MUNICIPAL WATER DISTRICT**  
4232 Las Virgenes Road, Calabasas CA 91302

**MINUTES**  
**REGULAR MEETING**

---

5:00 PM

May 10, 2016

**PLEDGE OF ALLEGIANCE**

The Pledge of Allegiance to the Flag was led by Lesli Stein.

**1. CALL TO ORDER AND ROLL CALL**

The meeting was called to order at **5:00 p.m.** by Board President Peterson in the Board Room at Las Virgenes Municipal Water District headquarters at 4232 Las Virgenes Road, Calabasas CA 91302. Josie Guzman, Clerk of the Board, conducted the roll call.

Present: Directors Charles Caspary, Jay Lewitt, Len Polan, Lee Renger, and Glen Peterson

Absent: None

Staff Present: David Pedersen, General Manager  
David Lippman, Director of Facilities and Operations  
Donald Patterson, Director of Finance and Administration  
Carlos Reyes, Director of Resource Conservation and Public Outreach  
Josie Guzman, Clerk of the Board  
Wayne Lemieux, District Counsel

**2. APPROVAL OF AGENDA**

Director Renger moved to approve the agenda as presented. Motion seconded by Director Lewitt. Motion carried unanimously.

### **3. PUBLIC COMMENTS**

None.

### **4. CONSENT CALENDAR**

**A Minutes: Special Meeting of April 18, 2016 and Regular Meeting of April 26, 2016 - Approve**

**B Directors' Per Diem – April 2016 - Ratify**

**C Financial Review: Third Quarter of Fiscal Year 2015-16**

**Receive and file the financial review for the third quarter of Fiscal Year 2015-16.**

**D Independent Auditor Services: Contract Amendment for Name Change**

**Authorize the General Manager to execute an amendment to the agreement for auditing services to reflect a name change from Pun & McGeady, LLP to the Pun Group, LLP.**

**E Annual Supply and Delivery of Ammonium Hydroxide: Award of Bid**

**Accept the bid from Airgas Specialty Products, Inc., and authorize the General Manager to approve an initial 13-month purchase order, in the amount of \$37,000, with four one-year renewal options, in the amount of \$34,106.10 per year, for the supply and delivery of ammonium hydroxide.**

**F List of Demands: May 10, 2016 - Approve**

Director Caspary moved to approve the Consent Calendar as presented. Motion seconded by Director Polan. Motion carried unanimously.

### **5. ILLUSTRATIVE AND/OR VERBAL PRESENTATION AGENDA ITEMS**

**A Poster Contest Awards Ceremony**

Tiffany Wright, Public Affairs Associate, provided introductory remarks and acknowledged school office managers, school principals, teachers, and family members for their support. She noted that the top five poster contest winners would have their original artwork submitted to Metropolitan Water District for the calendar contest.

Board President Peterson presented the awards to the top 12 finalists for this year's Water Awareness Poster Contest.

The Ann Dorgelo Water Awareness Perpetual Trophy was awarded to Bay Laurel Elementary School. Principal Steve Scifres and Ms. Kodama accepted the award.

## **B Legislative and Regulatory Updates**

General Manager David Pedersen reported that Governor Edmund G. Brown, Jr. issued Executive Order B-37-16, *Making Water Conservation a California Way of Life*. He noted that the Executive Order included actions to use water more wisely, eliminate water waste, strengthen local drought resilience, and improve agricultural water use efficiency and drought planning. He also noted that the Executive Order included provisions to make some of the water conservation measures permanent, extend the emergency declaration through January 31, 2017, and call upon the Department of Water Resources and the State Water Resources Control Board (Water Board) to develop a new, long-term framework for water use efficiency for beyond 20 by 2020. He stated there would be new permanent and mandatory targets established, which the District had already considered with the formation of the budget based rate structure. He noted that Governor Brown was also calling upon the Department of Water Resources and the Water Board to engage with water suppliers, environmental groups, and other stakeholders in preparing this framework by January 10, 2017. He also noted that the Water Board released a revised proposed framework for the emergency regulations, which would move away from conservation standards with the sliding scale based on 25 percent, require all wholesale and retail water suppliers to prepare supply and demand balances for the coming three years, and continue monthly reporting indefinitely. He noted that the new standards would become effective June 1, 2016, and the Water Board would receive comments up to May 18, 2016. He also reported that SB 814 (Hill) Drought: Excessive Water Use: Urban Retail Water Suppliers, had passed the Senate floor. He noted that this bill initially proposed stiff penalties for water wasting and would have mandated that water agencies impose a \$500 minimum penalty per unit of water. He stated that the bill was subsequently revised to provide a penalty of up \$500 per unit of water. He noted that the District would be in compliance with the proposed bill due to budget based rates and penalty structure. He also reported that S. 2848, the Water Resources Development Act of 2016 (WRDA) had passed through the Senate Environment and Public Works Committee with a 19-1 vote.

## **C Water Supply Conditions and Drought Response**

General Manager David Pedersen reported that Metropolitan Water District (MWD) lifted the Water Supply Allocation Program and instituted a Water Supply Alert. He stated that MWD anticipates adding 400,000 acre feet to storage this year. He also reported that the District achieved a 26 percent reduction in water usage for the month of April as compared to 2013, for a cumulative reduction of 28.3 percent.

### **6. TREASURER**

Director Lewitt stated that the Treasurer's report was in order.

### **7. BOARD OF DIRECTORS**

#### **A General District Election on November 8, 2016: Resolution No. 2492**

Pass, approve, and adopt proposed Resolution No. 2492, pertaining to a General District Election to be held in the District on Tuesday, November 8, 2016; and authorize the Board Secretary to submit certified copies of said resolution, completed Roster of Officeholders for Local Jurisdictions, and District Boundary Map to the Board of Supervisors and the Registrar-Recorder/County Clerk of the County of Los Angeles.

#### **RESOLUTION NO. 2492**

**A RESOLUTION OF THE BOARD OF DIRECTORS OF LAS VIRGENES MUNICIPAL WATER DISTRICT REQUESTING THE BOARD OF SUPERVISORS OF THE COUNTY OF LOS ANGELES TO PERMIT THE REGISTRAR-RECORDER/COUNTY CLERK TO RENDER ELECTION SERVICES FOR A GENERAL DISTRICT ELECTION TO BE HELD ON NOVEMBER 8, 2016**

(Reference is hereby made to Resolution No. 2492 on file in the District's Resolution Book and this reference the same is incorporated and made a part thereof.)

Director Renger moved to approve Item 7A as presented. Motion seconded by Director Lewitt. Motion carried unanimously.

### **8. FACILITIES AND OPERATIONS**

#### **A 2015 Urban Water Management Plan – Public Hearing**

**Conduct a public hearing to accept comments on the 2015 Urban Water Management Plan.**

Board President Peterson opened the Public Hearing at 5:39 p.m.

General Manager David Pedersen presented the report.

Catrina Paez, representing Kennedy/Jenks Consultants, provided a PowerPoint presentation and responded to questions posed by the Board.

Clerk of the Board/Deputy Secretary Josie Guzman noted that the City of Westlake Village submitted an email with no comments, and the City of Calabasas submitted comments related to projected growth.

There were no public comments.

Board President Peterson declared the Public Hearing closed at 5:58 p.m. The Board will consider adoption on May 24, 2016.

### **9. FINANCE AND ADMINISTRATION**

#### **A Claim from Stephen Heller on behalf of Stephen B. and Lily Ann Niefeld**

**Deny the claim from Stephen Heller on behalf of Stephen B. and Lily Ann Niefield.**

Director Renger moved to deny the claim. Motion seconded by Director Caspary.

General Manager David Pedersen responded to a question regarding the location of the vault cover by presenting an aerial photograph and noting that the vault cover is located outside of the District's service area boundary.

Motion carried unanimously.

## **10. NON-ACTION ITEMS**

### **A Organization Reports**

- (1) MWD Representative Report/Agenda(s)

Board President Peterson reported that the MWD Board discussed the purchase of the Delta Islands. He also reported that MWD held a two-day meeting to discuss the future of MWD and updating the Metropolitan Water District Act, which was originally adopted in the 1920's.

- (2) Other

### **B Director's Reports on Outside Meetings**

Director Polan reported that he attended the Association of California Water Agencies (ACWA) Spring Conference in Monterey, where he attended the Water Management Committee Meeting and sessions regarding the Delta Fix, Communications Committee Program, and engaging millennials.

Director Lewitt reported that he also attended the ACWA Spring Conference, where he attended the Federal Affairs Committee Meeting for an update on several bills. He also reported that he attended ethics training.

Board President Peterson reported that he also attended the ACWA Spring Conference and also attended the Communications Committee Program session. He noted that the Joint Powers Insurance Authority (JPIA) would now accept Las Virgenes Municipal Water District. He noted that the JPIA would continue to exclude the Central Basin Municipal Water District from the liability program. He also reported he attended the session regarding the Delta Fix.

Director Renger reported that he also attended the ACWA Spring Conference, where he attended a presentation by Sensus regarding automated meter infrastructure that can be used for meter reading and acoustic leak monitoring. He also reported that he attended a presentation by Sage Engineers and SunPower Corporation regarding solar power and a presentation regarding the drought's effect on trees.

## **C General Manager Reports**

### (1) General Business

General Manager David Pedersen noted the following events: the Solar Cup Challenge May 13th through 15th; potable water quarterly tour on May 14th; booth event for Agoura Hills Public Safety Day at the Agoura Hills Fire Station on May 14th; and Special JPA Meeting on May 11th.

### (2) Follow-Up Items

## **D Directors' Comments**

None.

## **11. FUTURE AGENDA ITEMS**

None.

## **12. PUBLIC COMMENTS**

None.

## **13. CLOSED SESSION**

The Board recessed to Closed Session at **6:26 p.m.** to discuss the following item:

### **A Conference with District Counsel – Existing Litigation (Government Code Section 54956.9(a)):**

1. Las Virgenes – Triunfo Joint Powers Authority v. United States Environmental Protection Agency and Heal the Bay, Inc. v. Lisa P. Jackson (TMDL cases)
2. Las Virgenes – Triunfo Joint Powers Authority v. United States Environmental Protection Agency (FOIA case)

## **14. OPEN SESSION AND ADJOURNMENT**

The Board reconvened to Open Session at **6:38 p.m.** District Counsel Wayne Lemieux reported there was no reportable action taken during the Closed Session.

Seeing no further business to come before the Board, the meeting was duly adjourned at **6:38 p.m.**



---

GLEN PETERSON, President  
Board of Directors  
Las Virgenes Municipal Water District

ATTEST:

---

CHARLES CASPARY, Secretary  
Board of Directors  
Las Virgenes Municipal Water District

(SEAL)



May 24, 2016 LVMWD Regular Board Meeting

TO: Board of Directors

FROM: Finance & Administration

**Subject : Cash and Investment Report for April 2016**

**SUMMARY:**

In April 2016, one investment was called and four investments were purchased. The average time to maturity for the portfolio increased to 2.4 years through the purchase \$4 million in bonds, maturing between April 13, 2020 and April 29, 2021 with current annualized yields between 1.25% and 2.00%. The District's total portfolio was valued at \$64,657,079 as of April 30, 2016, up 0.8% from March 31, 2016.

**RECOMMENDATION(S):**

Receive and file the Cash and Investment Report for April 2016.

**FISCAL IMPACT:**

No

**ITEM BUDGETED:**

No

**DISCUSSION:**

As of April 2016, the District held \$64,657,079 in its portfolio, up 1.6% year-over-year. The portfolio was also up slightly from the previous month's total of \$64,117,425. The majority of the funds were held in the District's investment accounts, which had an April 30, 2016 value of \$33,671,656. LAIF held the majority of the remaining funds in the amount of \$26,194,766. A small portion of the funds, \$2,013,053, were held in the pooled investment fund of CalTrust. A significant portion of remaining funds were held in a trustee account as required reserves for the bond refunding: \$2,760,955. The annualized yield for the District's investment portfolio was 1.22% in April 2016, up as compared to the prior month's return of 1.18%. The total yield

on the District's accounts was 0.90%, up from 0.71% year-over-year.

The following investment was called in April:

- 04/22 – FHLB purchased on 04/22/15, in the amount of \$1 million; 1.25%

The following investments were purchased in April:

- 4/4 – FHLMC callable in the amount of \$1 million; 1.25% up to 5.5%; matures 3/30/21
- 4/13 – FFCEB callable in the amount of \$1 million; 1.4%, matures 4/13/20
- 4/28 - State of California GO Bond in the amount of \$1 million; 1.5%; matures 4/1/21; Aa3/AA-
- 4/29 – FHLB callable in the amount of \$1 million; 2.0%; matures 4/29/21

The following transactions occurred in the District's LAIF account:

- |           |          |             |
|-----------|----------|-------------|
| • 4/4/16  | Withdraw | \$1,000,000 |
| • 4/13/16 | Withdraw | \$470,000   |
| • 4/15/16 | Interest | \$31,171.07 |
| • 4/29/16 | Withdraw | \$1,000,000 |

The District's investments are in compliance with the adopted Investment Policy, and sufficient funds are available to meet expenditures during the next six months from current rate revenue and funds held in LAIF.

#### Cash Analysis:

Another important aspect of the Monthly Cash and Investment Report is to monitor the District's performance compared to its adopted Financial Policies. Attachment B shows the District's total cash and investments as of April 30, 2016, and compares the balances to the adopted Financial Policies.

As can be seen by the analysis, as of April 30, 2016, the Potable Water Enterprise is \$10.2 million below the levels set forth in the District's Financial Policies. This is primarily due to a spend down of reserves for the Backbone Improvement Program and the use of \$2.7 million from the Rate Stabilization Fund in Fiscal Year 2015-16 to mitigate the effects of the drought on rates and in anticipation of the January 2016 rate structure change. The five-year rate plan was developed to re-build the reserves over the five-year period.

The Sanitation Enterprise has cash and investments that exceed the District's Financial Policies by \$12.4 million and the Recycled Water Enterprise has cash and investments that exceed the District's Financial Policy levels by \$13.1 million. These Enterprises are expected to incur significant expenses during the next five-year period in response to the need to comply with new National Pollution Discharge Elimination System (NPDES) permit requirements and the construction of a project to address seasonal storage needs in the Recycled Water Enterprise. These planned expenditures were also considered as part of the five-year rate plan that began in January 2016, and staff continues to explore additional funding options for these projects.

#### GOALS:

Ensure Effective Utilization of the Public's Assets and Money

Prepared by: Donald Patterson, Director of Finance and Administration

**ATTACHMENTS:**

Charts

April Investment Report

Attachment A

Attachment B

The District's total yield varies depending on the percentage of the portfolio in LAIF and CalTRUST versus the Investment Portfolio. If a higher percentage of the District's funds are in LAIF and CalTRUST, the lower the total yield since LAIF and CalTRUST are more liquid, more conservative, and have significantly lower yields than bonds held in the Investment Portfolio. As of April 2016, LAIF held 40.51% of the District's portfolio and the investment portfolio held 52.08%, the remainder was held in CalTRUST and Wells Fargo. As can be seen in the chart below, the total yield in April 2016 was 0.90%, 0.06% higher than March 2016 and up from 0.71% one year ago. The District's goal is to keep an amount equal to 6 months of operating budget in LAIF.

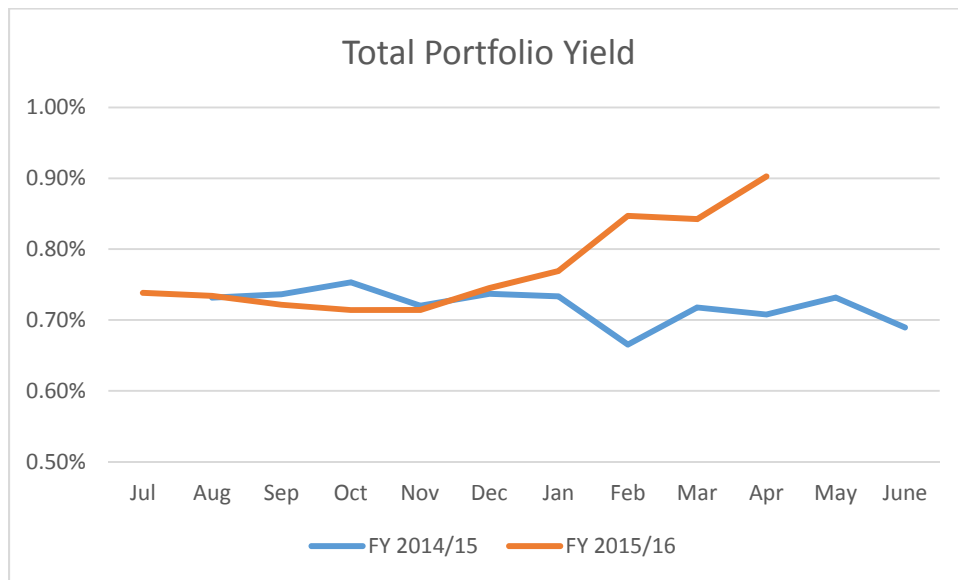

In April, the annualized yield for the District's Investment Portfolio was 1.22%, up from March's 1.18% and up 24 basis points from a year ago. The chart below shows annualized monthly yield of the current fiscal year compared with the same monthly yield over the previous fiscal year.

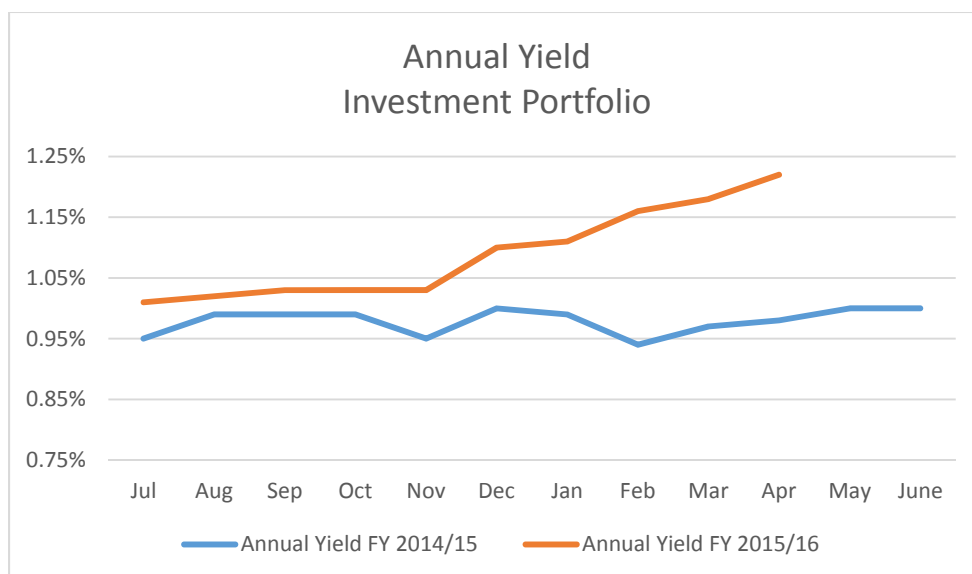

The following chart shows the average annualized LAIF and CalTRUST yields over the past twelve months. In April, the LAIF yield exceeded the CalTRUST yield by 2 basis points. The April LAIF yield was 0.53%, up from 0.28% a year ago and the CalTRUST yield was 0.51%, up from 0.37% from a year ago.

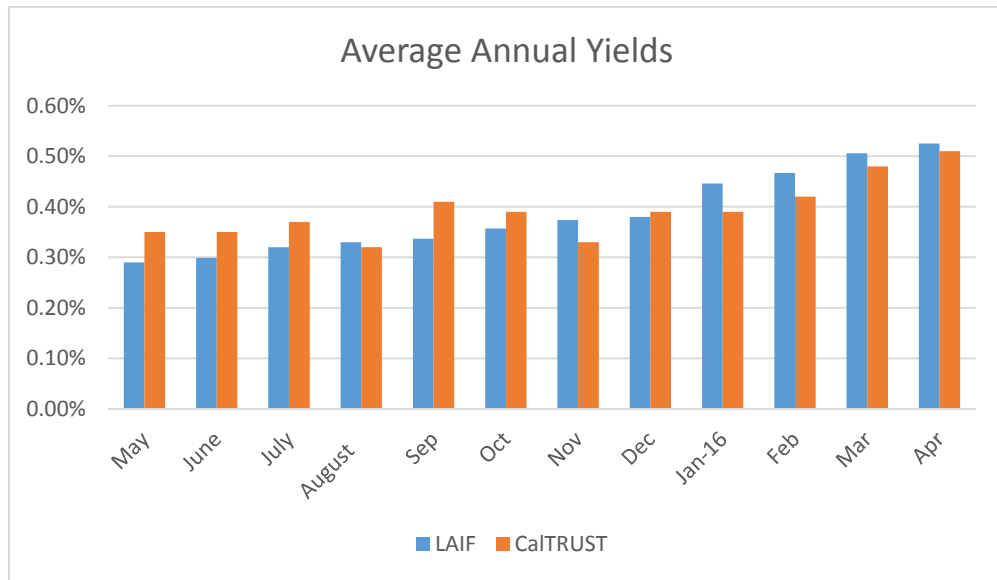

The District varies the time to maturity based on several factors including maintaining sufficient liquidity for anticipated capital expenditures, anticipated direction of future interest rates, and the quality of investments offered for a given maturity. In April, the average time to maturity was increased to 2.41 years from 2.20 years in March primarily due to the re-investment of called or matured securities. The District’s general target is 3.0 years.

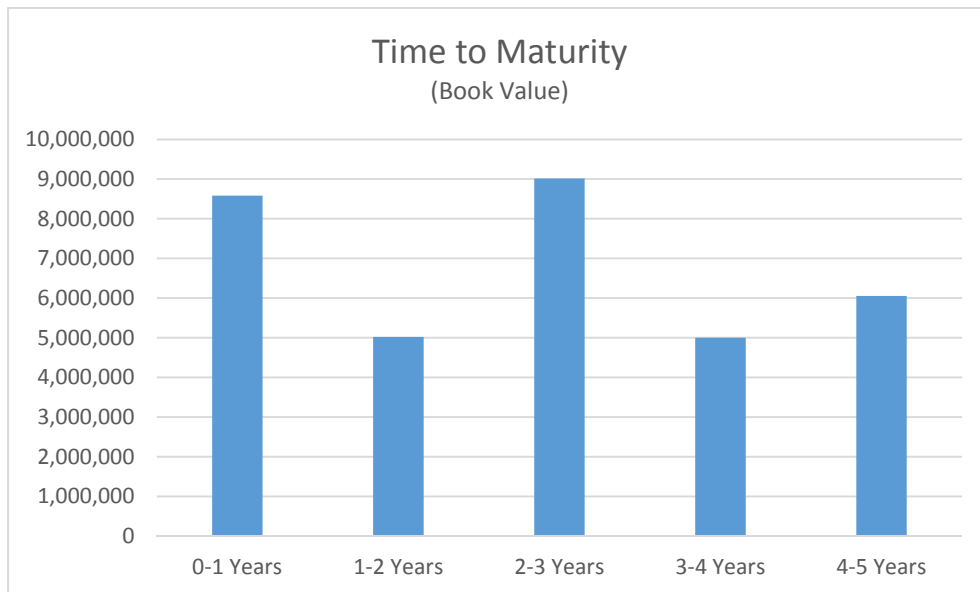

In order to benchmark how the District's portfolio is performing, it is useful to compare its investment portfolio with a comparable index. The District has historically compared its investment portfolio returns to the 2-Year and 3-Year Treasury notes. As shown in the chart below, the District's investment portfolio has generally mirrored the returns of the 3-Year Treasury. In November and December, Treasury Yields increased significantly as the Federal Reserve Bank Rate increased. The 3-year Treasury Notes hit 0.92% on April, 30, up from 0.87% on March 31, but still down from 1.31% at the start of January.

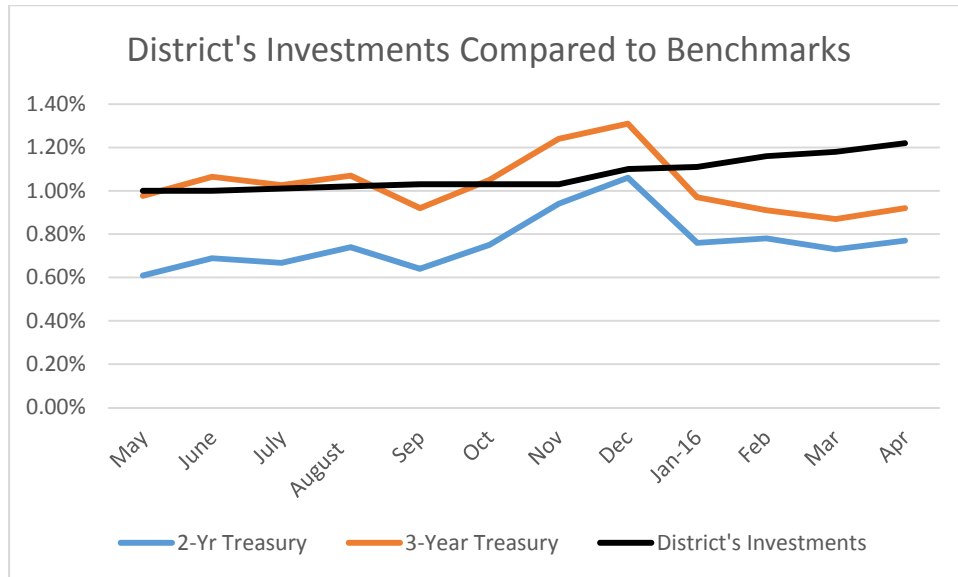

Equally important to monitoring performance is to monitor total portfolio value which includes the District's Investment Portfolio, LAIF and CalTRUST accounts. The chart below shows the Total Portfolio Value between 2009 and 2016. The chart demonstrates the effect of the Board's policy to minimize rate increases over the past 5 years and to utilize PAYGO for large capital projects by drawing down reserves. The significant reduction in 2014 is primarily because of the Torchwood Tank and the backbone improvement projects. In April, the District's portfolio increased 0.8% over March to \$64,657,079.

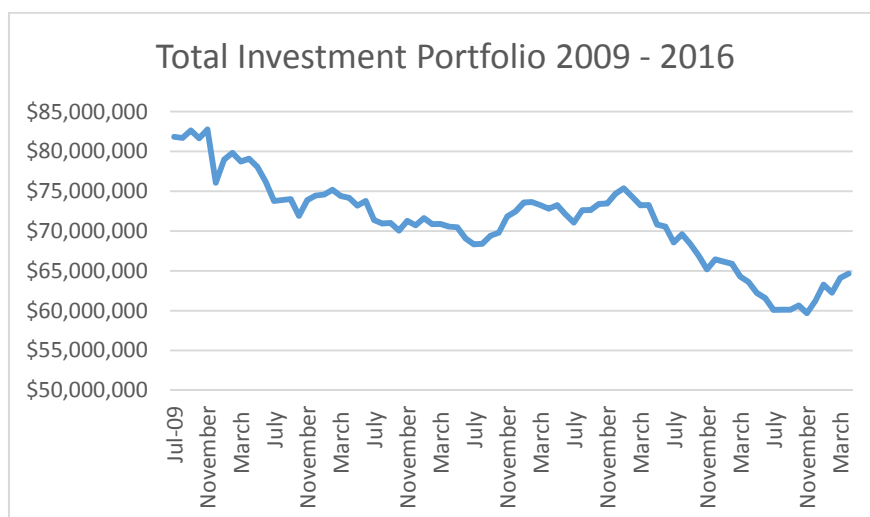

The chart below compares Total Portfolio Value in the current Fiscal Year, compared to the same period in the previous fiscal year.

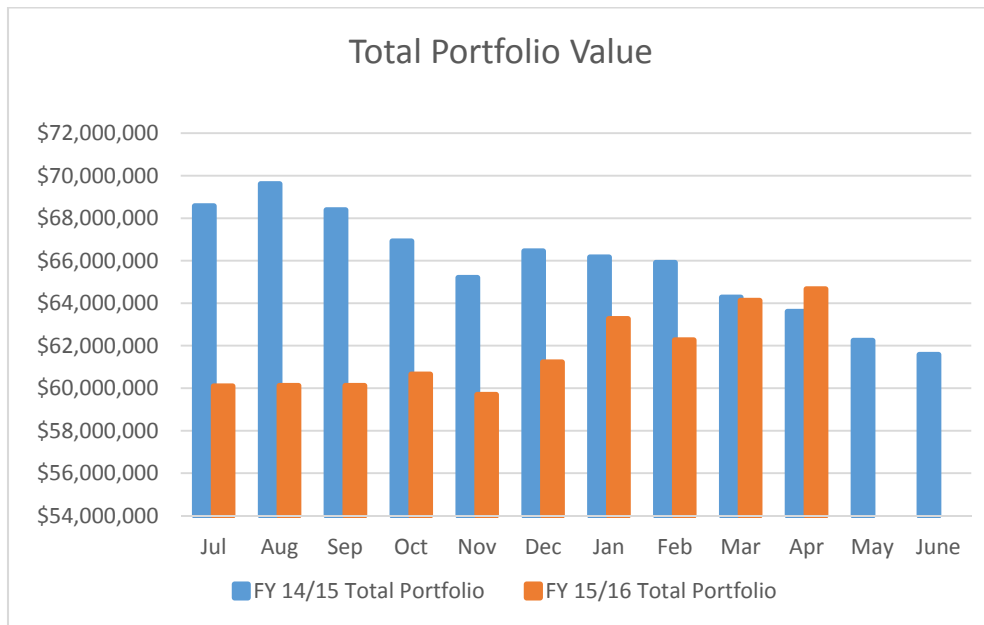

The chart below shows the value of the District’s Investment, LAIF and CalTRUST portfolios over the past twelve month period. The increase in LAIF since November reflects the District’s wait and see approach to how interest rates moved in response to December’s Federal Funds increase. In April, the District increased its investment portfolio due to positive interest rates offered during target maturity periods. In March, the value of LAIF increased as bonds were called and reinvested in issuances that settled in April.

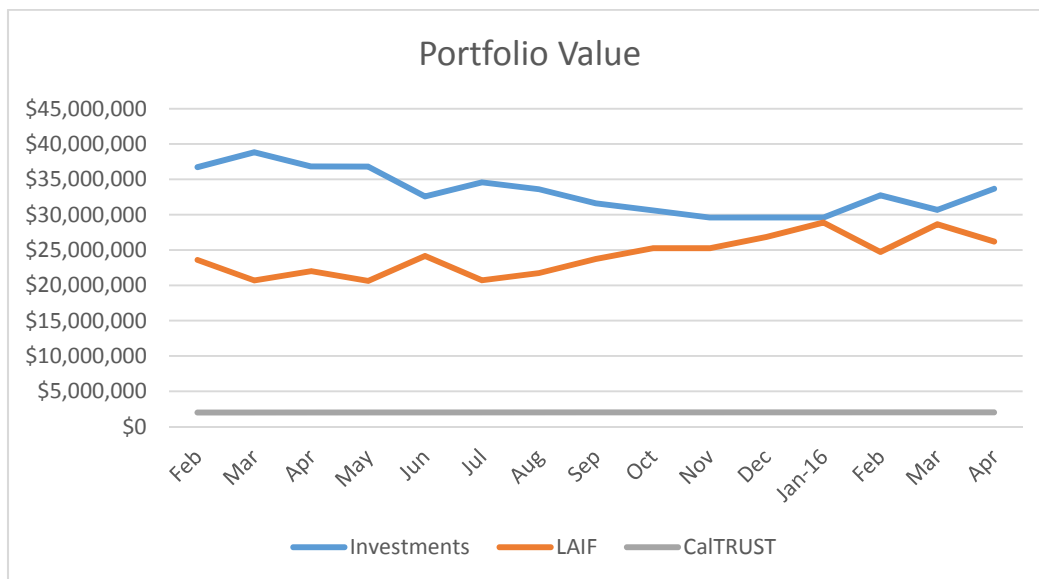



Date: May 12, 2016  
 To: David W. Pedersen, General Manager  
 From: Finance and Administration Department  
 Subject: Investment Report for the Month of April 2016

**Summary of Investments**

**Investments Maturing Within Six Months:**

Disc./Cpn Rate	Yield To Maturity	Yield To Call	Investment Type	Date Invested	Next Call Date	Date Matures	Book Value	Par Value	Market Value	Market Value Source
-- NONE --										
Sub-Total										
							0	0	0	
<b>Investments Maturing After Six Months:</b>										
0.625%	0.700%		FHLMC-Bullet	10/26/12		11/01/16	997,040	1,000,000	1,000,750	Custodian
0.690%	0.690%		PST-Muni Bond	03/26/13		11/01/16	1,000,000	1,000,000	999,610	Custodian
0.625%	0.625%		FNMA-Bullet	11/28/12		11/28/16	2,000,000	2,000,000	2,000,580	Custodian
0.600%	0.600%	0.600%	FFCB-Callable Coupon	12/13/12	Continuous	12/12/16	1,000,000	1,000,000	1,000,020	Custodian
0.832%	0.832%		ARLDEV-Muni Bond	06/03/13		12/15/16	1,585,000	1,585,000	1,584,334	Custodian
0.600%	0.600%		FFCB-Bullet	12/27/12		12/27/16	1,000,000	1,000,000	1,000,310	Custodian
1.270%	1.270%		FHLB-Bullet	03/30/12		03/02/17	1,000,000	1,000,000	1,005,540	Custodian
0.820%	0.860%	0.860%	FFCB-Callable Coupon	10/26/12	Continuous	07/11/17	998,000	1,000,000	1,000,000	Custodian
1.585%	1.100%		LVNSCD-Muni Bond	02/20/13		11/01/17	1,022,130	1,000,000	1,006,710	Custodian
0.750%	0.750%		FHLMC-Bullet	05/28/13		11/28/17	1,000,000	1,000,000	998,870	Custodian
1.000%	1.000%		FHLMC-Bullet	03/26/13		03/26/18	1,000,000	1,000,000	1,002,320	Custodian
1.020%	1.020%	1.043%	FHLMC-Callable Coupon	04/30/13	07/30/16	04/30/18	999,500	1,000,000	1,000,230	Custodian
0.950%	0.950%		FHLMC-Bullet	05/22/13		05/22/18	1,000,000	1,000,000	997,930	Custodian
0.75% & Up	1.117%	0.775%	FNMA-Callable Coupon	05/29/13	05/29/16	05/29/18	1,000,000	1,000,000	1,000,450	Custodian
1.250%	1.250%		FHLB-Bullet	06/26/13		06/26/18	1,000,000	1,000,000	1,007,740	Custodian
1.500%	1.500%	1.500%	FNMA-Callable Coupon	09/19/14	09/19/16	09/19/18	1,000,000	1,000,000	1,003,210	Custodian
1.300%	1.300%	1.300%	FHLB-Bullet	03/30/15		10/30/18	1,000,000	1,000,000	1,009,090	Custodian
1.500%	1.500%	1.500%	FHLB-Callable Coupon	03/13/15	03/13/17	03/13/19	1,000,000	1,000,000	1,003,560	Custodian
1.500%	1.500%	1.500%	FHLB-Callable Coupon	07/22/15	07/22/16	04/22/19	1,000,000	1,000,000	1,001,260	Custodian
1.550%	1.550%	1.550%	FNMA-Callable Coupon	12/10/15	06/10/16	06/10/19	1,000,000	1,000,000	1,000,430	Custodian
1.600%	1.600%	1.600%	FNMA-Callable Coupon	05/19/15	05/19/17	05/19/20	1,000,000	1,000,000	1,002,250	Custodian
1.150%	1.150%	1.150%	FFCB-Callable Coupon	02/23/16	05/23/16	11/23/18	1,000,000	1,000,000	999,450	Custodian
1.500%	0.983%		FHLB-Bullet	02/09/16		03/08/19	1,015,650	1,000,000	1,013,040	Custodian
1.350%	1.350%	1.350%	FNMA-Callable Coupon	02/26/16	08/26/16	08/26/19	1,000,000	1,000,000	997,140	Custodian

LVMWD Investment Report for the Month Ending April 30, 2016

Disc./Cpn Rate	Yield To Maturity	Yield To Call	Investment Type	Date Invested	Date Matures	Book Value	Par Value	Market Value	Market Value Source
<b>Investments Maturing After Six Months (continued):</b>									
1.375%	1.375%	1.376%	FHLMC-Callable Coupon	01/28/16	10/28/16	1,000,000	1,000,000	1,000,940	Custodian
1.300%	1.300%	1.300%	FNMA-Callable Coupon	02/24/16	02/24/17	1,000,000	1,000,000	996,840	Custodian
2.250%	1.732%		CONNECTICUT ST-MuniBoi	02/17/16	09/01/20	1,119,648	1,095,000	1,111,009	Custodian
2.427%	1.779%		NEWSCD-MuniBond	03/17/16	08/01/20	934,688	910,000	932,441	Custodian
1.25% & Up <sup>2</sup>	2.120%	1.250%	FHLMC-Callable Coupon	04/04/16	09/30/16	1,000,000	1,000,000	997,310	Custodian
1.400%	1.400%	1.400%	FFCB-Callable Coupon	04/13/16	04/13/17	1,000,000	1,000,000	999,280	Custodian
1.500%	1.500%		CAL ST-MuniBond	04/28/16	04/01/21	1,000,000	1,000,000	999,290	Custodian
2.000%	2.000%	2.000%	FHLB-Callable Coupon	04/29/16	07/29/16	1,000,000	1,000,000	1,002,380	Custodian
			Sub-Total			33,671,656	33,590,000	33,674,314	
			Total Investments			33,671,656	33,590,000	33,674,314	

Note: Gov. Agency Coupon Notes will distribute interest every six month.

1-CPNRT=0.75% to 5/16; 1% to 5/17; 2% to 11/17; thereafter 3%.

2-CPNRT=1.25% to 3/18; 1.75% to 9/19; 2.25% to 3/20; 3.5% to 9/20; thereafter 5.5%.

**Interest earnings for the month were as followed:**

	Amount Earned/Accrued	Current Yield
Refunding Revenue Bonds - Reserve Fund (Bank of New York Mellon) Investments	\$1,221	0.525%
Local Agency Investment Fund (LAIF)	31,519	1.220%
CalTrust Short-Term Fund	11,023	0.525%
Blackrock Liquidity Fund - US Treasury Money Market Fund (Union Bank)	1,153	0.510%
Sweep Accounts (Wells Fargo Bank/Bank of New York Mellon)	7	0.020%
	11	0.010%
<b>Total Earnings</b>	<b>\$44,934</b>	

**Schedule of Investment Balance Limitations (Per District investment policy)**

Total Amount Invested	% of Total	Max. Limit Allowed
\$33,671,656	52.08%	no limit
2,760,955	4.27%	1 yr debt pmt.
16,649	0.03%	no limit
26,194,766	40.51%	50,000,000
2,013,053	3.11%	no limit
<b>Total</b>	<b>100.00%</b>	

Note 1: The average weighted duration for investments, excluding LAIF, is 882 days, which is under the assumption that callable coupons will not be called and will be held until maturity.

Note 2: In April 2016, Joint Powers Authority's participation in investment is \$5,386,644.64, of which \$3,777,855.09 (or 70.13%) belongs to LV.

LVMWD Investment Report for the Month Ending April 30, 2016

Bank Account Balances as of April 30, 2016:

Bank Name	Account Type	Amount
Wells Fargo Bank	Checking	\$109,307 (Note 3)
Wells Fargo Bank	Sweep	756,817
Bank of New York Mellon	Money Market	391,013 (Fund is available for Debt Service Payment due on May 1, 2016)
	Total	<u>\$1,257,137</u>

Note 3: This is bank balance without adjusting for outstanding checks. The total amount of outstanding checks is unavailable at the time of reporting.

"All District investments are included in this report and all investments, except those relating to debt issues and deferred compensation programs funds, conform to District investment policy. All investment transactions within the period covered by this report, except for the exceptions noted above, conform to District investment policy. Deferred compensation program funds are not included in this report; their investment is directed by individual employees participating in the deferred compensation program and not by the District. Debt issue funds are included in this report; their investment is controlled by specific provisions of the issuance documents and not by the District."

"The deposits and investments of the District safeguard the principal and maintain the liquidity needs of the District, providing the District with the ability to meet expenditure requirements for the next six months. The maturity dates are compatible with foreseeable cash flow requirements. The deposits and investments can be easily and rapidly converted into cash without substantial loss of value."

Approved for May 24, 2016 Agenda:

 05/16/16  
David W. Pedersen, General Manager

I HEREBY CERTIFY THAT THE FOREGOING IS TRUE AND CORRECT

TO THE BEST OF MY KNOWLEDGE

Jay Lewitt, Treasurer

Definitions

- Disc./Cpn Rate – The yield paid by a fixed income security.
- Yield to Maturity – The rate of return of a security held to maturity when interest payments, market value and par value are considered.
- Yield to Call – The rate of return of a security held to call when interest payments, market value and par value are considered.
- Bullet – A fixed income security that cannot be redeemed by the issuer until the maturity date.
- Callable – A fixed income security that can be redeemed by the issuer before the maturity date.
- Book Value – The price paid for the security.
- Par Value – The face value of a security.
- Market Value – The current price of a security.
- Custodian – The financial institution that holds securities for an investor.

Investment Abbreviations

- FHLB – Federal Home Loan Bank
- FHLMC – Federal Home Loan Mortgage Corporation (Freddie Mac)
- FNMA – Federal National Mortgage Association (Fannie Mae)
- FFCB – Federal Farm Credit Bank
- Bonds
  - LVNSCD – Las Virgenes Unified School District
  - PST – Port of Seattle
  - ARLDEV – Arlington County Development Authority Revenue Bond
  - CON ST – State of Connecticut General Obligation Bond
  - NEWSCD – Newark, CA Unified School District
  - CAL ST – State of California General Obligation Bond

## LVMWD CASH &amp; INVESTMENT ANALYSIS - April 30, 2016

	Restricted Cash	Cash Held by Policy	Policy Requirement	Over (Short) Policy
101 - Potable Water Operations		1,061,053	8,245,415	(7,184,361)
201 - Potable Water Construction	52,202	4,088,323	4,360,000	(271,677)
301 - Potable Water Replacement		5,300,000	8,000,000	(2,700,000)
603 - Rate Stabilization Fund				
<b>Total Potable Water</b>	<b>52,202</b>	<b>10,449,377</b>	<b>20,605,415</b>	<b>(10,156,038)</b>
102 - Recycled Water Operations		10,094,764	1,066,799	9,027,966
203 - Recycled Water Construction	1,051,440			
302 - Recycled Water Replacement		4,292,431	200,000	4,092,431
<b>Total Recycled Water</b>	<b>1,051,440</b>	<b>14,387,195</b>	<b>1,266,799</b>	<b>13,120,397</b>
130 - Sanitation Operations		16,670,469	2,859,496	13,810,973
230 - Sanitation Construction	(5,091)			
330 - Sanitation Replacement		3,233,232	4,600,000	(1,366,768)
<b>Total Sanitation</b>	<b>(5,091)</b>	<b>19,903,701</b>	<b>7,459,496</b>	<b>12,444,206</b>
606 & 607 - Refunding Revenue Bonds - Reserve Fund	3,151,968			
701 - Vested Sick Leave Reserve	1,315,555			
720 - Insurance Reserve		3,311,962	3,300,587	11,376
JPA	5,454,640			
Prepaid Connection Fees & Undistributed Interest	6,257,848			
<i>Subtotal</i>	<u>17,278,562</u>	<u>48,052,236</u>		
<b>TOTAL</b>	<b>65,330,798</b>	<b>0</b>		

**Financial Policy** - Cash required to comply with District's adopted Financial Policy.

**Restricted Cash** - Revenue restricted to a particular purpose.

**Bond Covenants** - Money relating to bond financing that is restricted in use and required by promises made in bond documents. Funds are reconciled at year-end.



May 24, 2016 LVMWD Regular Board Meeting

TO: Board of Directors

FROM: Finance & Administration

---

**Subject : Supply and Delivery of Pressure Regulators: Award**

---

**SUMMARY:**

On April 12, 2016, the Board approved a Request for Bids for the annual supply and delivery of pressure regulators. Three bids were received and publicly opened. The lowest apparent bid was from Famcon Pipe & Supply, Inc. However, the bid was deemed non-responsive because the pressure regulator proposed did not meet the maximum working pressure rating required in the specifications. As a result, staff recommends the Board accept the next lowest bid from Ferguson Waterworks.

**RECOMMENDATION(S):**

Accept the bid from Ferguson Waterworks for the annual supply and delivery of pressure regulators and authorize the General Manager to approve an initial 13-month purchase order, in the amount of \$85,003.65, with four one-year renewal options for the same amount.

**FISCAL IMPACT:**

Yes

**ITEM BUDGETED:**

Yes

**FINANCIAL IMPACT:**

The total estimated annual cost to the District for pressure regulators is \$85,003.65. Sufficient funds for the purchase of pressure regulators are available in the adopted Fiscal Year 2015-16 Budget and will be proposed in future budgets.

**DISCUSSION:**

The Pressure Regulator Inspection and Replacement Program was implemented in Fiscal Year 2013-14; however, higher priority maintenance items delayed completion of the program. Staff has refocusing attention on the program, which requires the District's warehouse to stock large quantities of 1-inch and 1 1/4-inch pressure regulators. The program consists of conducting annual inspections of pressure regulators and replacing those that are failing or aged (10+ years).

It is anticipated that several hundred regulators will be replaced in Fiscal Year 2016-17. All items purchased will become part of the District's warehouse inventory with the actual costs expensed as the items are utilized. The initial purchase order is proposed for a 13-month period, intended to align the contract period with the fiscal year. Four one-year renewal options, in the same amounts as the initial purchase order, are recommended to allow continuation of the program.

**Bid Process:**

A Request for Bids was posted on the District's website, advertised in *The Daily News*, and sent to 11 different vendors who previously expressed an interest in waterworks bids. Three bid responses were received and publicly opened. The apparent low bid was submitted by Famcon Pipe & Supply, Inc., in the amount of \$84,543.13. However, the regulators proposed by Famcon bid did not meet the maximum working pressure rating required by the bid specifications. As a result, the Famcon bid was deemed non-responsive. The next lowest bid was submitted by Ferguson Waterworks, in the amount of \$85,003.65.

Attached is a copy of the Ferguson Waterworks bid.

**Bid Summary:**

<b><u>Bidder</u></b>	<b><u>Bid Total</u></b>
<b>Ferguson Waterworks</b>	<b>\$85,003.65</b>
HD Supply Waterworks Limited	\$86,367.79
Famcon Pipe & Supply, Inc.	\$84,543.13 (non-responsive)

**GOALS:**

Ensure Effective Utilization of the Public's Assets and Money

Prepared by: Gretchen Bullock, Purchasing Supervisor

**ATTACHMENTS:**

Pressure Regulators - Ferguson Bid

**Las Virgenes Municipal Water District  
Bid Form-Schedule  
Pressure Regulators—Annual Supply**

The undersigned states and declares as follows: that the bidder has carefully read and examined the Bid Documents; Bid Notice; Instruction to Bidders; Bid Specifications including exhibits; Bid Form-Schedule; and that the bidder will comply with the bid terms and conditions. The undersigned agrees to supply and deliver materials in strict conformity with the specifications and instructions enclosed with the Invitation for Bids for the prices set forth below in this bid schedule.

It is understood that this bid shall remain open and shall not be withdrawn for a period of at least ninety (90) days from the date prescribed for the opening of the bid.

It is further agreed that the materials/services to be furnished under this bid shall be delivered at such time and in such quantities as called for by the Las Virgenes Municipal Water District. The District may extend the term of this contract by written notice to the supplier at the end of the contract period.

CONTRACT TERM as follows: initial contract term shall be good for 13 months from May 1, 2016 through June 30, 2017. Four (4) additional one (1) year renewals may be negotiated at the District's option.

Materials to be furnished under this bid shall be delivered FOB Destination Freight Pre-Paid and Allowed to Las Virgenes Municipal Water District's Headquarters, 4232 Las Virgenes Road, Calabasas, CA 91302 in the manner set forth in the Bid Scope and Specifications.

All bidders are required to submit the following information with their bid

- Completed Bid Form-Schedule
- Product information/technical data sheet with schematic
- Contact information for three public entity customers bidder is currently supplying with Pressure Regulators

The bidder's authorized officer identified below hereby declares that the representations in this bid are true and correct and of my own personal knowledge, and that these representations are made under penalty of perjury under the laws of the State of California, and that I am duly authorized to bind this bidder to this bid.

---

*>>>continued on next page<<<*

---



Bid Item No.	Quantity	Unit of Measure UOM	Description Refer to Bid Scope & Specifications for detailed description	Unit Price	Extended Price
1.	350	Each	1" Pressure Regulator  Manufacturer: <i>WILKINS</i>  Part #: <i>NR3XLDUSCPHRSCL</i>  Preset PSI: <i>75</i>	<i>125<sup>40</sup></i>	<i>43890<sup>00</sup></i>
2.	150	Each	1 1/4" Pressure Regulator  Manufacturer: <i>WILKINS</i>  Part #: <i>NR3XLDUSCPHRSCL</i>  Preset PSI: <i>75</i>	<i>227<sup>30</sup></i>	<i>34095<sup>00</sup></i>
			CA Sales Tax (9 % as of 5/4/16)		<i>7018<sup>65</sup></i>
			Total Bid	\$	<i>85003<sup>65</sup></i>

Written Total Bid Amount:

*EIGHTY FIVE THOUSAND THREE DOLLARS AND SIXTY FIVE CENTS*

Manufacturer Preset PSI:

*75*

Notes or Exceptions:

*N/A*

Addendum Acknowledgement:

Addendum #1

Signed: \_\_\_\_\_

Addendum #2

Signed: \_\_\_\_\_

>>>continued on next page<<<

Bidder:

Ferguson Enterprises, Inc  
DBA Ferguson Waterworks

5-2-16

Corporate Name of Bidder

Date

By:

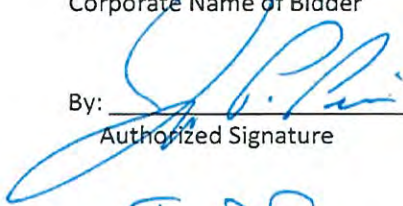

Title:

General Manager

Authorized Signature

Jon P. Price

jon.price@ferguson.com

Print Name

E-mail

858 - 391 - 3700

Phone

11909 Tech Center Ct. Pajaro CA 92064

760 - 807 - 6342

Address

Mobile

Local Address: 3681 Market St. Ventura CA

PH# 805-644-7279 93003



# Model NR3XL

Water Pressure Reducing Valve with Integral  
By-Pass Check Valve and Strainer

### Application

Ideal for use where Lead-Free\* valves are required. Designed for installation on potable water lines to reduce high inlet pressure to a lower outlet pressure. The Integral strainer makes this device most suitable for residential and commercial water systems that require frequent cleaning of sediment and debris. The direct acting integral by-pass design prevents buildup of excessive system pressure caused by thermal expansion. The balance piston design enables the regulator to react in a smooth and responsive manner to changes in system flow demand, while at the same time, providing protection from inlet pressure changes.

### Standards Compliance

- ASSE® Listed 1003
  - IAPMO® Listed
  - CSA® Certified
  - NSF® Listed - Standard 61 & 372\*
  - Certified to NSF/ANSI 372\* by IAPMO R&T
- (\*0.25% MAX. WEIGHTED AVERAGE LEAD CONTENT)

### Materials

Main valve body	Low Lead Cast bronze ASTM B 584
Bell housing	UV resistant polymer composite
Internals	Stainless steel, 300 Series
Stem	Low Lead Brass
Elastomers	EPDM (FDA approved) Buna nitrile (FDA approved)
Cartridge	Delrin™ (NSF Listed)
Springs	302 Stainless Steel
Strainer screen	300 Series Stainless Steel

### Features

Sizes:	1/2", 3/4", 1", 1-1/4", 1-1/2", 2"
Max. working water pressure (1/2" - 1-1/4")	400 psi
Minimum Inlet pressure =	80 psi as per UPC Code
Max. working water pressure (1-1/2" - 2")	300 psi
Max. working water temperature	140°F
Reduced pressure range (1/2" - 1-1/4")	15 to 75 psi
Reduced pressure range (1-1/2" - 2")	25 to 75 psi
Factory preset	50 psi
Threaded connections (FNPT)	ANSI B1.20.1
Copper connections (FC)	ANSI B16.22
CPVC tailpiece: Max.hot water temp.	140°F @ 100 psi
Cold water rated temp.	73.4°F @ 400 psi

### Dimensions & Weights (do not include pkg.)

SIZE		CONNECTIONS	DIMENSIONS (approximate)								WEIGHT	
In.	mm		A		B		C		D		lbs.	kg
1/2	15	SINGLE UNION	4 3/8	111	6 1/4	159	1 1/8	29	2 1/2	64	3	1.5
1/2	15	LESS UNION	3 1/2	89	6 1/4	159	1 1/8	29	2 1/2	64	3	1.5
1/2	15	DOUBLE UNION	5 1/4	133	6 1/4	159	1 1/8	29	2 1/2	64	3	1.5
3/4	20	SINGLE UNION	4 7/16	113	6 1/4	159	1 1/8	29	2 1/2	64	3	1.5
3/4	20	LESS UNION	3 1/2	89	6 1/4	159	1 1/8	29	2 1/2	64	3	1.5
3/4	20	DOUBLE UNION	5 3/8	137	6 1/4	159	1 1/8	29	2 1/2	64	3	1.5
3/4	20	DOUBLE MALE METER	3 5/8	92	6 1/4	159	1 1/8	29	2 1/2	64	3	1.5
1	25	SINGLE UNION	4 15/16	125	6 1/4	159	1 1/8	29	2 1/2	64	4	2
1	25	LESS UNION	4	102	6 1/4	159	1 1/8	29	2 1/2	64	3.5	1.6
1	25	DOUBLE UNION	5 15/16	151	6 1/4	159	1 1/8	29	2 1/2	64	4.5	2.1
1	25	DOUBLE MALE METER	4	102	7 3/4	197	1 3/16	30	3	76	4	2.0
1 1/4	32	SINGLE UNION	6 3/16	157	7 3/4	197	1 3/16	30	3	76	5.5	2.5
1 1/4	32	LESS UNION	6	127	7 3/4	197	1 3/16	30	3	76	5	2.3
1 1/4	32	DOUBLE UNION	7 3/8	187	7 3/4	197	1 3/16	30	3	76	6	2.7
1 1/2	40	SINGLE UNION	6 5/16	160	8 1/2	216	1 3/4	45	3 3/4	95	6.6	3
1 1/2	40	LESS UNION	6	127	8 1/2	216	1 3/4	45	3 3/4	95	5.5	2.5
1 1/2	40	DOUBLE UNION	7 1/2	191	8 1/2	216	1 3/4	45	3 3/4	95	7.7	3.5
2	50	SINGLE UNION	8 1/4	169	8 1/2	216	2	51	3 3/4	95	8.1	3.7
2	50	LESS UNION	6	127	8 1/2	216	2	51	3 3/4	95	6.7	3
2	50	DOUBLE UNION	7 1/2	191	8 1/2	216	2	51	3 3/4	95	9.5	4.3



### Options

(Suffixes can be combined)

- standard with single union FNPT connection and 20 mesh strainer screen
- C - with FC (copper sweat) union connection
- DM - with double male 3/4" & 1" meter threads connection with SS spring & sealed cage
- G - tapped with gauge
- DU - with double union connection (FNPT)
- DULU - with 2 integral FNPT connection (no union)
- PEX - with male barbed connection tailpiece for crossed-linked polyethylene tubing
- PEXF1960- with male barbed connection PEX tailpiece conforming to ASTM F1960
- SC - with ss adjustment bolt and lock nut with ss spring for below-ground installations
- P - tapped and plugged for gauge
- CPVC - CPVC tailpiece connection (3/4" - 1")
- HRSC - High Range 15-150 psi (1/2"-1-1/4" only) with sealed cage
- DUPF - with 2 Z-Bite™ push fit tailpiece connection 250 psi max pressure (1/2" - 1" only)
- DUPR - with 2 Z-Press™ press fit tailpiece connection 250 psi max pressure (3/4" - 2" only)
- DULUPF- with 2 integral Z-Bite™ push fit connections 250 psi max pressure
- DULUPR- with 2 integral Z-Press™ press fit connections 250 psi max pressure

### Accessories

- Repair kit
- 1" BR4DUSPC Special plastic spacer nipple
- 1-1/4" BR4DUSPC Steel pipe
- 1-1/2" NR3DUSPC Steel pipe
- 2" NR3DUSPC Steel pipe
- TPKXL Lead-Free Tailpiece kit
- TPKXLPF Z-Bite™ push fit Tailpiece kit 250 psi max pressure (1/2"-1" only)
- TPKXLPR Z-Press™ press fit Tailpiece kit 250 psi max pressure (3/4"-2" only)

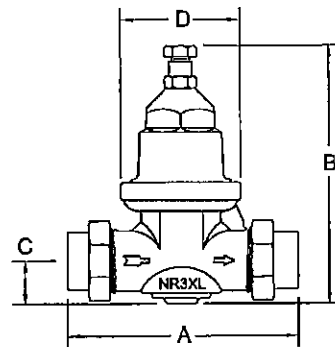

Zurn Industries, LLC | Wilkins  
1747 Commerce Way, Paso Robles, CA U.S.A. 93446 Ph. 855-883-9876, Fax 805-238-5766  
In Canada | Zurn Industries Limited  
3544 Nashua Drive, Mississauga, Ontario L4V 1L2 Ph. 905-405-8272, Fax 905-405-1292  
[www.zurn.com](http://www.zurn.com)

Rev. H  
Date: 3/16  
Document No. REG-NR3XL  
Product No. Model NR3XL

**Flow Characteristics**

◇ Rated Flow (established by approval agencies)

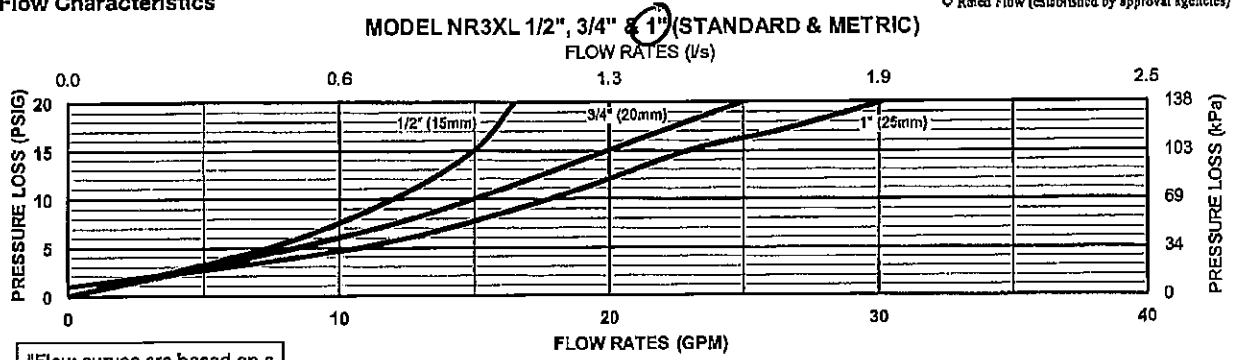

"Flow curves are based on a 50 psi pressure differential"

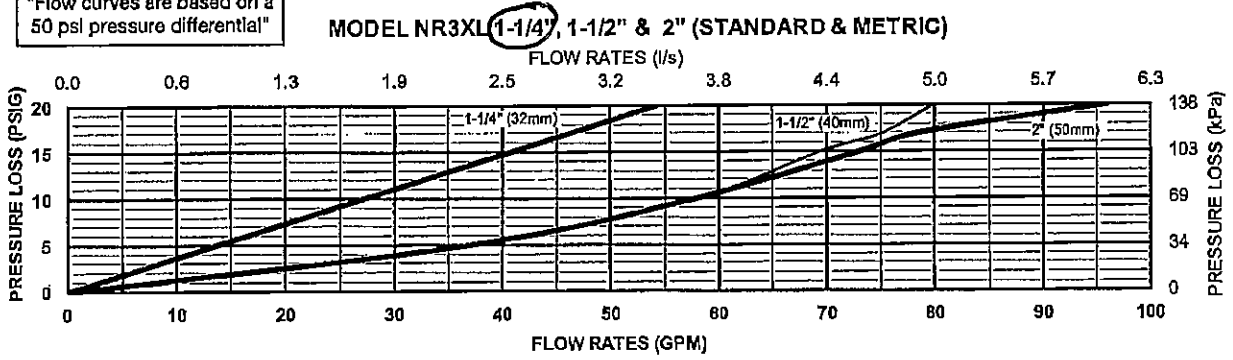

**Typical Installation**

Local codes shall govern installation requirements. Unless otherwise specified, the assembly shall be mounted in accordance with the latest edition of the Uniform Plumbing Code. The Model NR3XL may be installed in any position. If installed in a pit, vault, or inside application, specify the "SC" sealed cage option. The assembly shall be installed with sufficient side clearance for testing and maintenance. Multiple installations are recommended for wide demand variations or where the desired pressure reduction is more than 4 to 1 (ie: 200 psi inlet reduced to 50 psi outlet). **CAUTION:** Anytime a reducing valve is adjusted, a pressure gauge must be used downstream to verify correct pressure setting. Do not bottom adjustment bolt on bell housing.

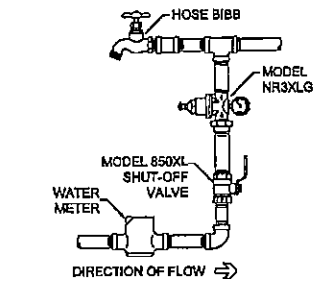

**OUTDOOR INSTALLATION**

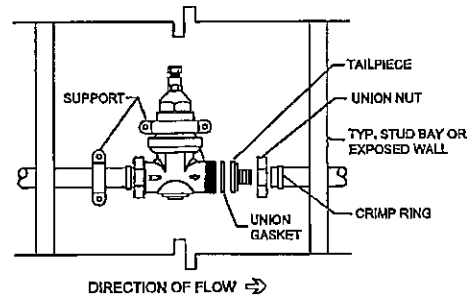

**NR3XLDUPEX INSTALLATION**

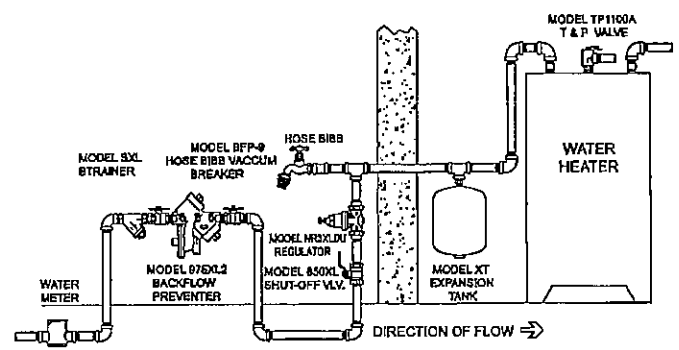

**TYPICAL INSTALLATION**

**Specifications**

The Water Pressure Reducing Valve shall be certified to NSF/ANSI 372 and ASSE® Listed 1003, available with single union, double union and less union end connections. The main body shall be low lead cast bronze (ASTM B 584) alloy. The bell shall be composite plastic. The cartridge shall be NSF® Listed acetal and incorporate an integral seat. The seat disc elastomer shall be NSF® Listed EPDM. The assembly shall be accessible for maintenance without removing the device from the line. The Water Pressure Reducing Valve shall be a ZURN WILKINS Model NR3XL.

Zurn Industries, LLC | Wilkins  
 1747 Commerce Way, Paso Robles, CA U.S.A. 93446 Ph. 855-683-9876, Fax 805-238-5766  
 In Canada | Zurn Industries Limited  
 3544 Nashua Drive, Mississauga, Ontario L4V 1L2 Ph. 905-405-8272, Fax 905-405-1292  
[www.zurn.com](http://www.zurn.com)

# WATER SUPPLY CONDITIONS CRA

As of: 05/09/2016

## 2016 Colorado River

**865,000 AF**  
69% of full CRA  
(Does not include storage withdrawals or exchanges)

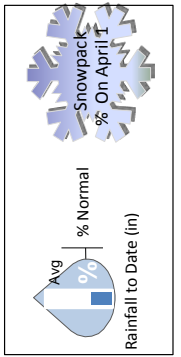
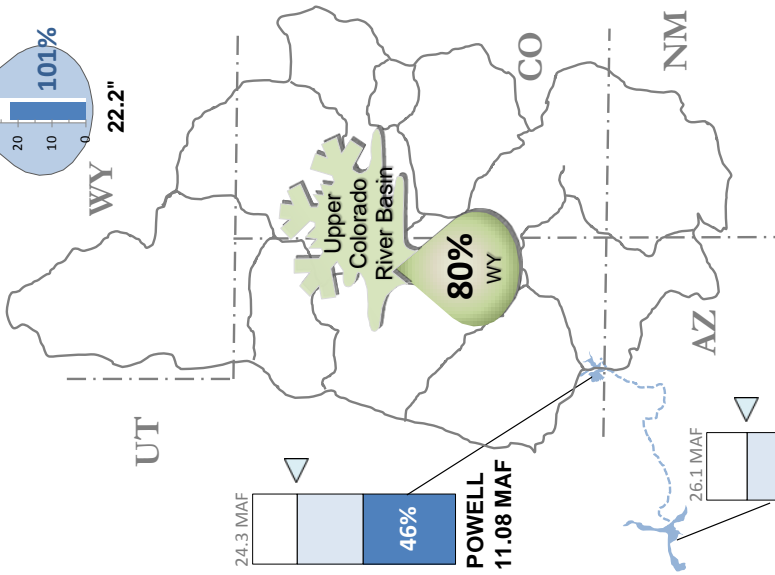
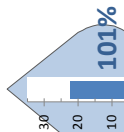
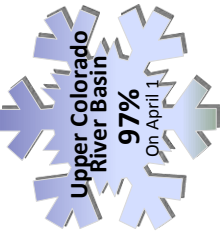

# 1997-98 vs. 2015-16 El Niño Signal

## Sea Surface Temperature

Pacific Ocean Niño Region 3.4

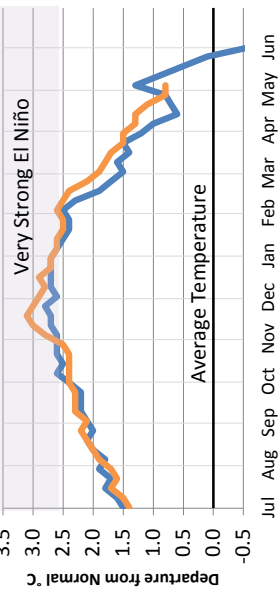

## Downtown Los Angeles Precip

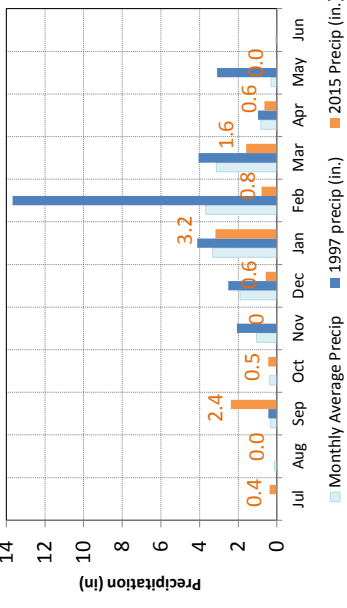

## Diamond Valley Lake Storage

Capacity: 810 TAF

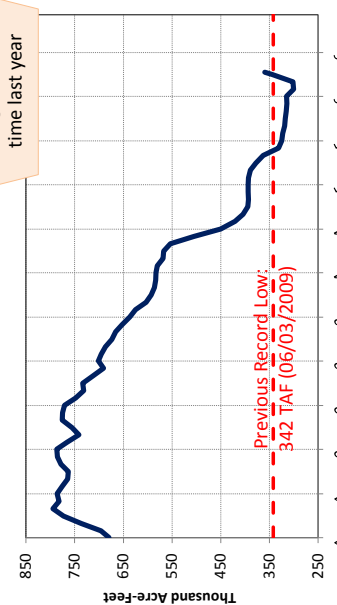

## Southern Sierra Snowpack

71% of Normal on April 1

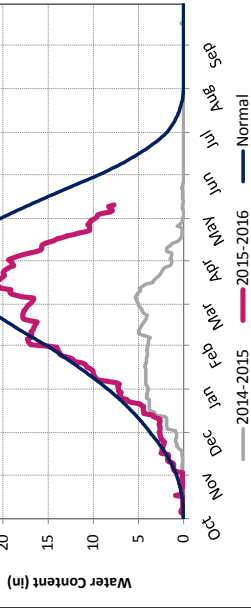

## MWD Storage Reserve Levels

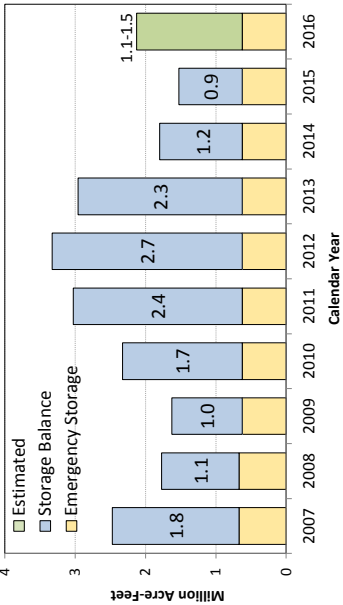

## Lake Shasta Reservoir Storage

Capacity: 4.55 MAF

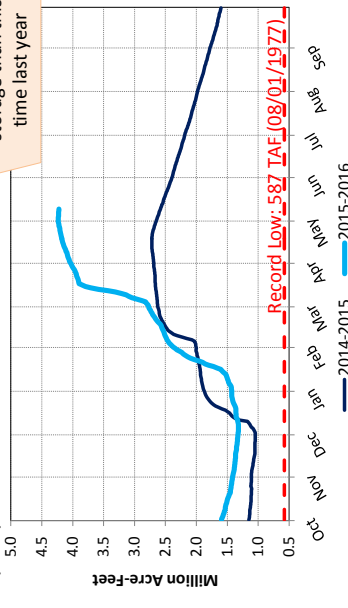

# WATER SUPPLY CONDITIONS SWP

As of: 05/09/2016

## 2016 SWP Allocation

**1,146,900 AF**  
60% of Table A

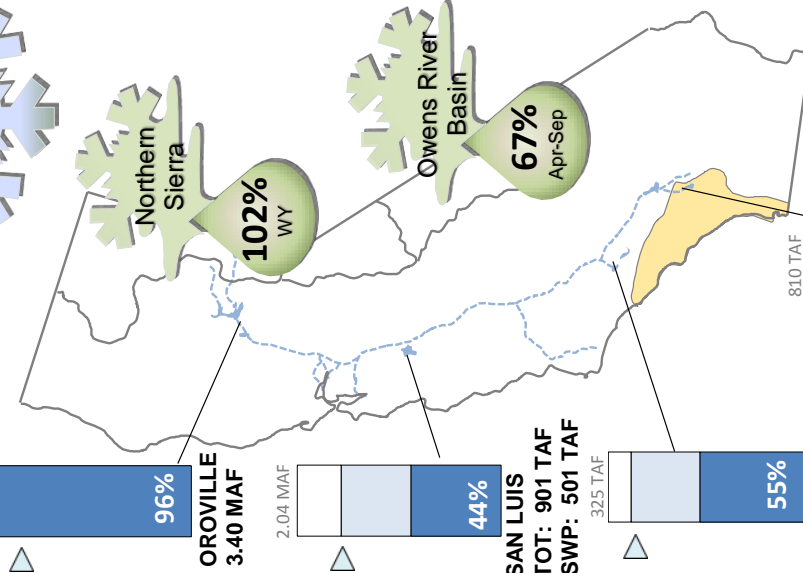
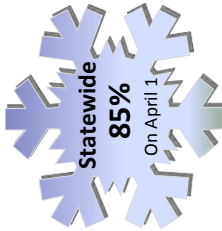

# State Water Project Resources

As of: 05/09/2016

## Northern Sierra Snowpack

95% of normal on April 1

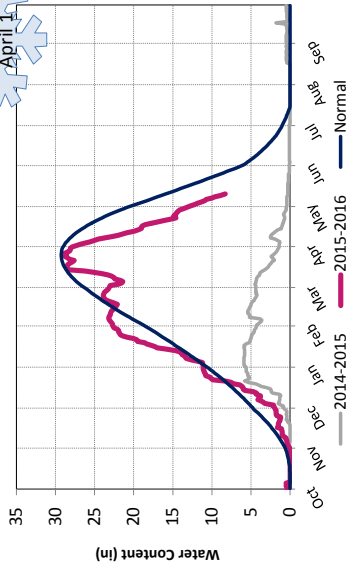

## 8 Station Index Precip

55.5 in. Water Year to Date

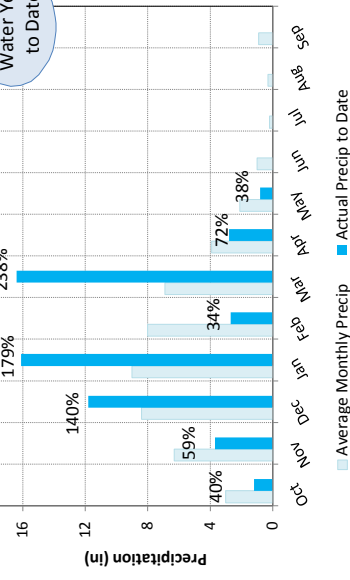

## 5 Station Index Precip

39.2 in. Water Year to Date

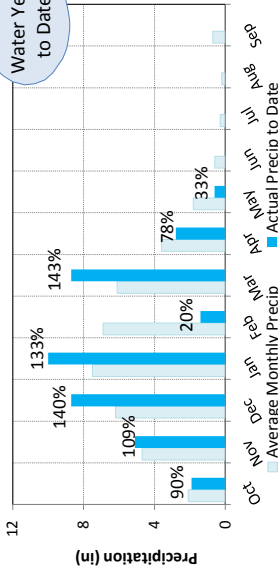

## Other SWP Contract Supplies for 2016 (AF)

Transfer Supplies	TBD
Multi Year Pool	7,000
Pool A/B (Purchased)	0
Article 56 (Prior Cal. Year(s) CO)	2,400

## Sacramento River Runoff

102% of normal (forecast)

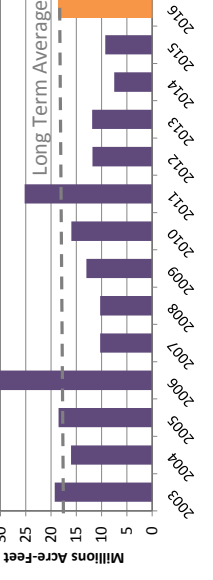

# Colorado River Resources

As of: 05/09/2016

## Northern Sierra Snowpack

97% of normal on April 1

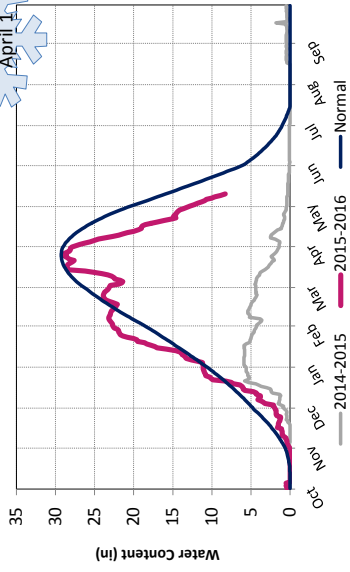

## Upper Colorado Basin Precip

22.2 in. Water Year to Date

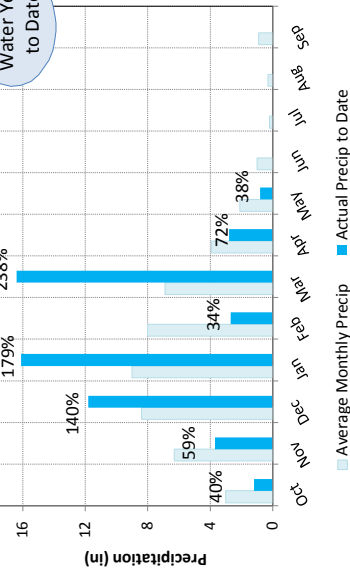

## Upper Colorado Basin Snowpack

97% of normal on April 1

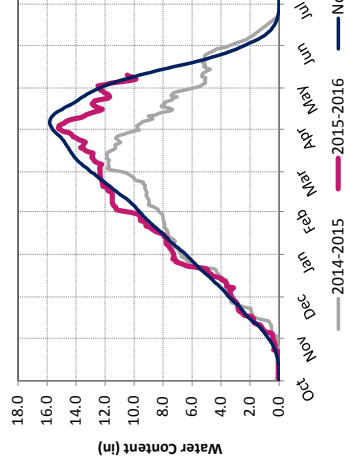

## Oroville Reservoir Storage

1.70 MAF more in storage than this time last year

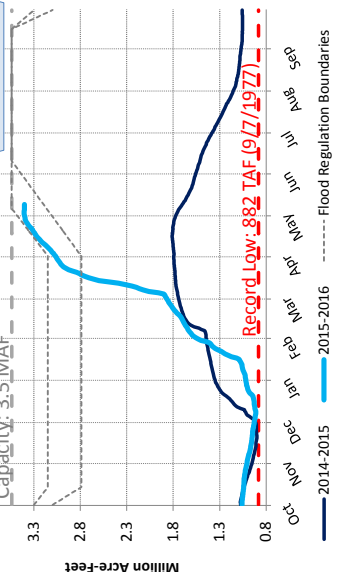

## Colorado River Ag Use Forecast

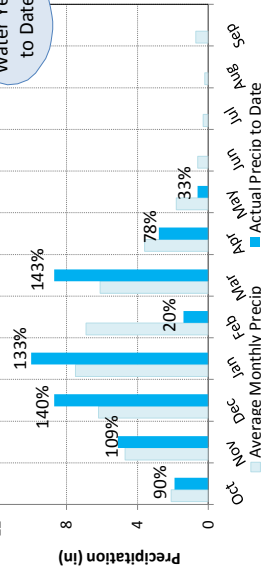

## Lake Powell Storage

227 TAF more in storage than this time last year

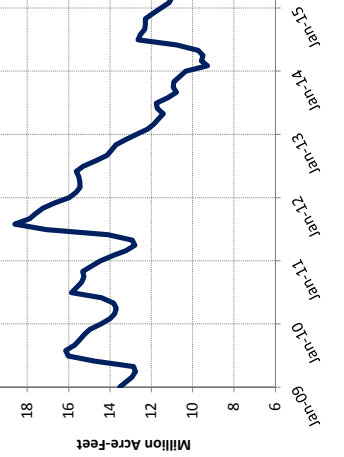

## San Luis Reservoir Storage

354 TAF less in SWP storage than this time last year

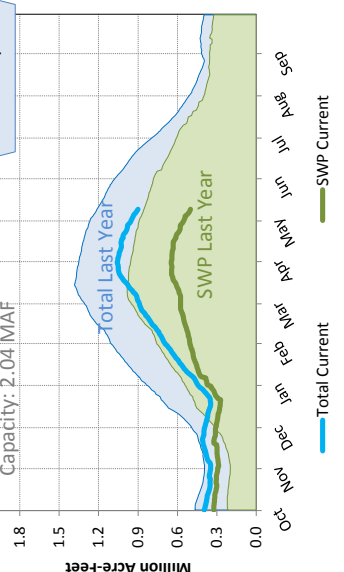

## Lake Mead Storage

202 TAF less in storage than this time last year

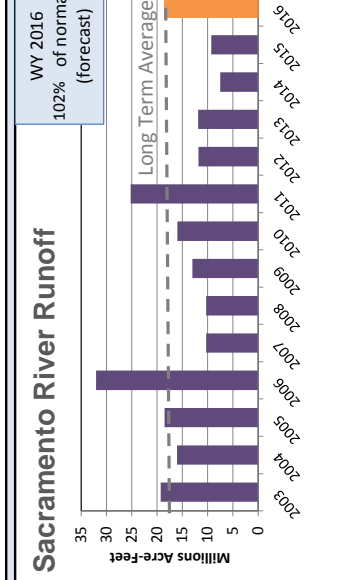

## Lake Mead Shortage/Surplus Outlook

	2017	2018	2019	2020	2021
Shortage	10%	56%	64%	64%	61%
Surplus	0%	<1%	4%	8%	12%

Likelihood based on results from the April 2016 USBR WOTM/Colorado River Simulation System model run

## Powell Unregulated Inflow

WY 2016 80% of normal (forecast)

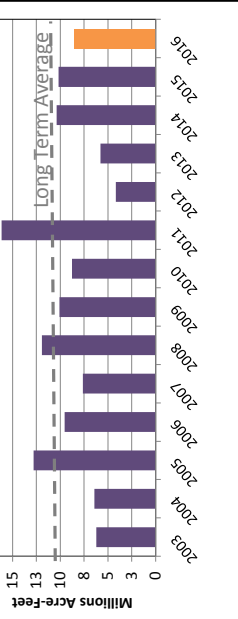

# Castaic Lake Storage

Combination Water/Calendar Year

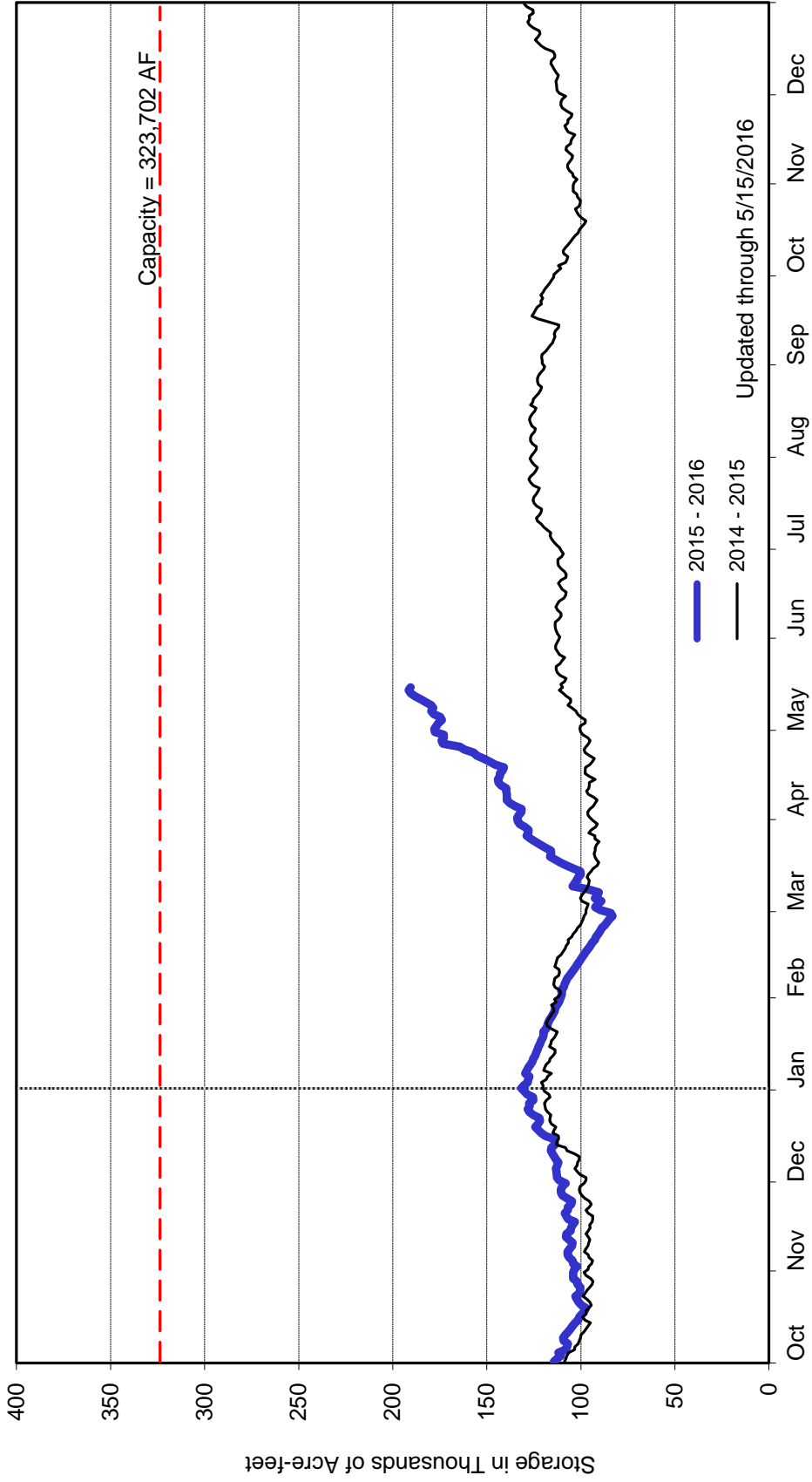





May 24, 2016 LVMWD Regular Board Meeting

TO: Board of Directors

FROM: Facilities & Operations

**Subject : 2015 Urban Water Management Plan: Adoption**

**SUMMARY:**

On March 1, 2016, a notice of preparation for the 2015 Urban Water Management Plan (UWMP) was sent to the Metropolitan Water District of Southern California, Triunfo Sanitation District, Calleguas Municipal Water District, the County of Los Angeles, and the cities within the District's service area. Also, copies of the draft 2015 UWMP were made available for public review at [www.lvmwd.com](http://www.lvmwd.com) and District Headquarters. A public hearing was held by the Board on May 10, 2016.

The City of Westlake Village acknowledged receipt of the draft report but had no comments. The City of Calabasas provided comments on population projections included in the 2015 UWMP; the final report incorporates changes to address these comments. No other comments on the 2015 UWMP have been received to-date. Staff will provide a verbal update on any final comments received prior to Board's adoption of the 2015 UWMP.

**RECOMMENDATION(S):**

Pass, approve and adopt Resolution No. 2493, adopting the 2015 Urban Water Management Plan.

**RESOLUTION NO. 2493**

**A RESOLUTION OF THE BOARD OF DIRECTORS OF THE LAS VIRGENES MUNICIPAL WATER DISTRICT ADOPTING THE 2015 URBAN WATER MANAGEMENT PLAN**

(Reference is hereby made to Resolution No. 2493 on file in the District's Resolution Book and by this reference the same is incorporated herein.)

**FISCAL IMPACT:**

No



**ITEM BUDGETED:**

Yes

**FINANCIAL IMPACT:**

There is no financial impact associated with this action.

**GOALS:**

Provide Safe and Quality Water with Reliable Services

Prepared by: John Zhao, P.E., Principal Engineer

**ATTACHMENTS:**

Proposed Resolution No. 2493

**RESOLUTION NO. 2493**

**A RESOLUTION OF THE BOARD OF DIRECTORS OF THE  
LAS VIRGENES MUNICIPAL WATER DISTRICT  
ADOPTING THE 2015 URBAN WATER MANAGEMENT PLAN**

**WHEREAS,** Las Virgenes Municipal Water District has completed an update to its 2010 Urban Water Management Plan (2015 UWMP), including the implementation of a plan to reduce water consumption by 20% by 2020; and

**WHEREAS,** Las Virgenes Municipal Water District has conducted a public hearing to solicit community input regarding the plan,

**NOW THEREFORE, BE IT RESOLVED** by the Board of Directors of Las Virgenes Municipal Water District that the 2015 Urban Water Management Plan, Report # 2728.00 is hereby adopted.

**PASSED, APPROVED AND ADOPTED** this 24th day of May 2016.

---

Glen Peterson  
President

ATTEST:

---

Charles P. Caspary  
Secretary

(SEAL)

APPROVED AS TO FORM:

---

Wayne K. Lemieux  
District Counsel



May 24, 2016 LVMWD Regular Board Meeting

TO: Board of Directors

FROM: Facilities & Operations

---

**Subject : Twin Lakes Tanks Drainage Project: Award of Construction Contract**

---

**SUMMARY:**

On March 8, 2016, the Board authorized the Call for Bids for the Twin Lakes Tanks Drainage Project. Eight bids were received and publically opened on May 11, 2016. The lowest responsive bid was submitted by Spiess Construction Company, Inc. (Spiess), in the amount of \$201,366, which was approximately 4% below the Engineer's Estimate. The Spiess bid had a minor irregularity because proof of registration with the Department of Industrial Relations (DIR) was not included with the bid package. However, it was confirmed that Spiess was registered with the DIR at the time of bidding, and District Legal Counsel determined the minor irregularity can be waived. Staff recommends award of a construction contract to Spiess.

**RECOMMENDATION(S):**

Find that the project is categorically exempt from the California Environmental Quality Act; waive a minor bid irregularity and award a construction contract to Spiess Construction Company, Inc., in the amount of \$201,366; approve an increase, in the amount of \$4,760, to the an existing contract with Phoenix Civil Engineering; and authorize the General Manager to execute a Temporary Construction and Permanent Easement Agreement for the Twin Lakes Tanks Drainage Project.

**FISCAL IMPACT:**

Yes

**ITEM BUDGETED:**

Yes

**FINANCIAL IMPACT:**

The total estimated project cost is \$300,263. No additional appropriation is required. The adopted Fiscal Year 2015-16 Budget provides partial funding, in the amount of \$263,348, for the project under CIP Job No. 10568. The proposed Fiscal Year 2016-17 Budget includes an additional \$42,421, as the construction contract spans both fiscal years.

Following is a summary of the total estimated project cost:

Construction Contract	\$201,366
Construction Contract Change Order Contingency (10%)	\$ 20,137
District Labor	\$ 24,000
G&A	\$ 48,000
Easement	\$ 2,000
<u>Design Services During Construction</u>	<u>\$ 4,760</u>
Total estimated project cost	\$300,263

## **DISCUSSION:**

### Background:

Twin Lakes Tank No. 1 was constructed in 1966, and Tank No. 2 was constructed in 1991. The original drainage facilities for the site were designed to discharge any surface water or accidental tank overflows to the north of the site. The water was to follow the natural land contours across several vacant private parcels and ultimately flow into the County's drainage system. Attached for reference is the site map showing the existing flow path.

Several nearby vacant private parcels have been developed since 1991. A tank overflow in 2014 due to a communication failure caused damages to one of the improved properties on Iverson Road. Modification of the tank overflow drainage system at the Twin Lakes Tank site is necessary to prevent potential future damages to the downstream properties. The completed design involves construction of piping to take any tank overflow and diverts it south into a Caltrans storm drain system under California State Route 118.

The existing catch basin drainage system at the Twin Lakes Tanks Site will be used to divert rain runoff to the north of the site, as is currently the case, because flows during a rain event are anticipated to be minimal given the small footprint of the site. Additionally, Caltrans limits diverting surface runoff to their storm drain system.

### Temporary Construction and Permanent Easement Agreement:

The proposed drainage pipeline will cross a private parcel (APN No. 2821-013-023), owned by ERP Operating Limited Partnership (ERP). As a result, a temporary construction and permanent easement is required for the project. ERP agrees to offer the easement, as described in the attached Temporary Construction and Permanent Easement Agreement, in exchange for reimbursement, in an amount not to exceed \$2,000, for its legal costs associated with drafting and reviewing the documents.

### Environmental Review:

The work is categorically exempt from the California Environmental Quality Act (CEQA), pursuant to Section 15301(b) of the CEQA Guidelines. The project involves a minor addition to an existing facility with no expansion of use. Attached is a Notice of Exemption that staff proposes to complete and file, pending Board approval of the CEQA determination.

Design Services during Construction:

On July 8, 2014, the Board awarded a design contract to Phoenix Civil Engineering, in the amount of \$40,955, which included services through bidding but not design support services during construction. Staff recommends the Board approve a \$4,760 increase in the existing contract with Phoenix for design services during construction. The work would include responding to contractor requests for information, reviewing submittals, attending meetings, and preparing record drawings.

Bid Summary:

After waiving one minor bid irregularity, the lowest responsive bid was submitted by Spiess Construction Company, Inc., in the amount of \$201,366, which was approximately 4% lower than the Engineer's Estimate of \$209,200.

Following is a summary of the eight bids received:

Spiess	\$ 201,366.00
Bosco	\$ 224,900.00
GSE	\$ 247,905.00
Blois	\$ 291,151.00
Toro	\$ 300,005.00
United Engineering	\$ 308,201.00
Zusser	\$ 315,600.00
Pyramid Building and Engineering	\$ 339,801.74

**GOALS:**

Construct, Manage and Maintain All Facilities and Provide Services to Assure System Reliability and Environmental Compatibility

Prepared by: Eric Maple, P.E., Associate Engineer

**ATTACHMENTS:**

Site Map  
Temporary Construction and Permanent Easement Agreement  
Notice of Exemption



Las Virgenes Municipal Water District is not responsible for the accuracy of this presentation. This presentation is for illustrative purposes only. Verify the physical location of all property lines, water lines and ancillary information prior to use.



Sources: Esri, DeLorme, HERE, USGS, Intermap, increment P Corp., NRCAN, Esri Japan, METI, Esri China (Hong Kong), Esri (Thailand), TomTom

# PROPOSED ROUTE



RECORDING REQUESTED BY  
AND WHEN RECORDED MAIL TO

Equity Residential  
Two North Riverside Plaza, Suite 400  
Chicago, Illinois 60606  
Attn: Caroline Hammond

SPACE ABOVE THIS LINE FOR RECORDER'S USE

Document Title: **TEMPORARY CONSTRUCTION AND PERMANENT EASEMENT AGREEMENT**

Grantor: ERP OPERATING LIMITED PARTNERSHIP

Grantee: LAS VIRGENES MUNICIPAL WATER DISTRICT

Legal Description: Portion of Section 12, Township 2 North, Range 17 West, San Bernadino Meridian, Los Angeles County, California

Full Legal Description: See Exhibit A attached

Assessor's Tax Parcel No.: 2821-013-023

Reference Nos of Documents Released or Assigned: N/A

THIS TEMPORARY CONSTRUCTION AND PERMANENT EASEMENT AGREEMENT (this "Agreement"), made as of the 25 day of April, 2016 (the "Effective Date"), by and between ERP OPERATING LIMITED PARTNERSHIP, an Illinois limited partnership, as Grantor, and LAS VIRGENES MUNICIPAL WATER DISTRICT, a quasi-municipal corporation of the State of California, as Grantee. The designation Grantor and Grantee as used herein shall further include their respective successors, assigns and future owners of the real property subject to this Agreement and shall include singular, plural, masculine, feminine or neuter as required by context.

#### RECITALS

A. Grantor is the owner of the unimproved real property located in the City of Los Angeles, County of Los Angeles, State of California, legally described on Exhibit A attached hereto and incorporated herein by this reference, being located north of California State Highway 118 and west of 11450 Poema Place, Chatsworth, Los Angeles County, California ("Grantor's Property").

B. Grantee desires to construct and maintain a drainage pipeline and related facilities (collectively, the "Grantee Improvements") over, across and under Grantor's Property to connect to its existing tank facilities located north of Grantor's Property

## AGREEMENT

**NOW, THEREFORE**, for good and valuable consideration, the receipt and adequacy of which are hereby acknowledged, the parties agree as follows

1. **TEMPORARY CONSTRUCTION EASEMENTS.** Grantor hereby grants to Grantee a non-exclusive temporary construction easement upon those areas of Grantor's Property legally described in Exhibit B and depicted graphically in Exhibit C attached hereto (the "Temporary Construction Easement"). The Temporary Construction Easement is granted solely for the purpose of allowing the Grantee to construct a drainage pipeline and related facilities upon Grantor's Property (the "Work"). The Temporary Construction Easement not commence until Grantee shall have provided Grantor with the proof of insurance required by Section 4 of this Agreement and will terminate upon the completion of Grantee's construction but in no event later than March 31, 2017. Grantee has furnished Grantor with plans and specifications for the Work.

(a) In addition to satisfying all of the requirements of Section 4 of this Agreement, Grantee will provide at least two working days advance notice prior to entering upon Grantor's Property and commencing the performance of the Work.

(b) Following notice and Grantor's review and approval, Grantee will cause the Work to be constructed **strictly** in accordance with the Plans. Grantee will not suffer or permit any material changes to be made to the Plans without Grantor's prior review and approval. Grantee shall, at its own cost and expense, be responsible for performing the Work in accordance with sound and generally accepted engineering and construction practices and procedures, and in accordance with any standards and specifications which may be prescribed by any governmental or quasi-governmental body or authority having jurisdiction. Grantee shall be responsible for obtaining and maintaining any and all required permits and approvals applicable to the Work and shall pay all fees and expenses in connection with the Work. Within ten (10) days after completion of the Work, Grantee shall, at its sole cost and expense and in an expeditious and workmanlike manner, restore Grantor's Property to mitigate the effects of any erosion damage or susceptibility to erosion and repair to prior condition any ingress and egress routes or facilities if damaged by Grantee's or its contractors' activity.

(c) All Work shall be conducted solely during business hours (8:00 a.m. to 4:30 p.m. Mondays through Fridays, excepting legal holidays).

(d) Grantee hereby acknowledges its understanding that gas mains and lines, water piping, storm and sanitary sewers, electrical transmission, communications and other utility systems, facilities or easements may lie within the Easements granted herein. Grantee shall be solely responsible, at its own cost and expense, for verifying and locating such existing easements, systems and facilities in each instance in which it performs any Work. Notwithstanding the foregoing, Grantor agrees to reasonably cooperate with Grantee by making available all information in Grantor's possession. Grantee hereby expressly agrees that its rights hereunder shall be subject to other existing easements, improvements, covenants, encumbrances, utilities and other matters of record in Los Angeles County, California and Grantor's Property. Grantee hereby expressly agrees to avoid any damage to or interference with such utilities or any other utilities and expressly agrees that in the event of any damage to or interference with any such or other utilities or improvements or with any other encumbrances, utilities, or matters of record, or easement rights, such damage or interference shall be rectified at Grantee's sole cost and expense. Grantee further agrees to cooperate with all other grantees having or acquiring similar rights within or serving Grantor's Property.

2. **PERMANENT EASEMENT; ACCESS AND MAINTENANCE.** Upon completion of construction of Grantee's Improvements, Grantee will cause a legal description and graphic depiction of that portion of Grantor's Property in which the as built Grantee Improvements are located (the "Permanent Easement Area"). Such legal description and graphic depiction will be attached hereto as Exhibit B and Exhibit C, respectively, to replace said Exhibits attached upon execution of this Agreement. So long as the Grantee Improvements remain upon Grantor's Property, Grantee will at all times be responsible to maintain the Grantee Improvements in good order, condition and repair. Grantor may, but will not be obligated to, provide notice to Grantee from time to time that one or more of the Grantee



Improvements are in need of repair and maintenance, and promptly following such notice from Grantor, Grantee will arrange to perform such maintenance and repair in accordance with the terms and provisions of this Agreement. The Easements include rights of ingress and egress across Grantor's Property for the purpose of maintenance and repair of the Grantee Improvements, including access to Grantor's Property by way of the access gate and road in Summerset Village on parcel number 2821-013-020 that leads to Grantor's Property; provided, however, that Grantee shall provide Grantor with not less than two working days prior notice of its request for access to any of the Grantee Improvements for the purpose of conducting repair or maintenance. Such notice will include a detailed description of the exact nature of the repair or maintenance work Grantee intends to perform upon the subject Grantee Improvements, together with plans and specifications for such work. All repair and maintenance work required for the Grantee Improvements will be subject to the same requirements that apply to the Work in Sections 1 and 3 through 5 of this Agreement.

**3. GRANTEE'S INDEMNITY.** Grantee will indemnify, defend and hold Grantor, Equity Residential, Equity Residential Management, L.L.C., their subsidiaries, affiliates, trustees, directors, officers, shareholders, employees, agents, members, partners, successors and assigns ("Indemnified Parties") from and against any and all claims, expenses (including, without limitation, attorneys' fees and disbursements), demands, liabilities, injuries, damages and actions, known or unknown, directly or indirectly, which arise out of, are alleged to have arisen out of, relate to, or are in connection with, any act or omission of Grantee, its contractors, or any subcontractor retained by Grantee or its contractors, or any of their respective agents, servants, or employees in connection with the existence, repair and maintenance of Grantee's Improvements, any Work to be performed from time to time and any other obligations contemplated in this Agreement. The obligations under this Section 3 shall survive termination of this Agreement. If any mechanic's or materialmen's lien is filed against Grantor's Property for work or materials done or furnished to Grantee in connection with the Work, the lien shall be discharged by Grantee within thirty (30) days of the date of receipt by Grantee of actual notice of such lien solely at Grantee's expense, by paying off or bonding over the lien. If Grantee shall fail to discharge such lien, Grantor may do so and shall be entitled to collect from Grantee costs reasonably incurred by Grantor to discharge such lien. The terms of this Section shall survive termination of this Agreement.

**4. INSURANCE.** Prior to commencing the Work or any repair and maintenance work on Grantee's Improvement under the permanent easement granted by Section 2 of this Agreement, **Grantee** shall obtain and maintain in full force, at **Grantee's** own expense, insurance as provided in the Section against claims which may arise out of or result from the performance of the Work by the **Grantee**, its Contractor and Subcontractors of any tier, or by anyone directly or indirectly employed by any of them, or by anyone for whose acts any of them may be liable. So long as Grantee's Contractor's insurance provided coverage for all acts and omissions of all of its Subcontractors of any tier, or by anyone directly or indirectly employed by Grantee's Contractor, such Subcontractors and others need not provide the insurance required by this Section 4. All insurance shall be written by companies that are authorized to write business in the State in which work is to be performed and have, at all times a Best's rating of "A- X" or better by AM Best & Company, and with coverage and policy limits as Owner may reasonably require (unless otherwise specified herein):

- 1 Commercial General Liability insurance written on Insurance Services Office ("ISO") Commercial General Liability Coverage "occurrence" form CG 00 01 or another Commercial General Liability "occurrence" form providing equivalent coverage and including Broad Form Comprehensive General Liability coverage, blanket contractual liability coverage, Independent Contractors coverage, coverage for bodily injury (including death), property damage (including loss of use thereof) and products and completed operations with limits of not less than \$25,000,000 per occurrence. Limits may be provided in a "layered" program utilizing primary, umbrella or excess liability policies and shall maintain coverage for at least 3 years following completion of the Work or any repair and maintenance work on Grantee's Improvement under the permanent easement; provided, however, that (i) Grantee's Contractors are required to maintain coverage for at least one year in lieu of three years; (ii) Grantee's Contractor's policy limits may equal not less than \$10,000,000 per occurrence; and (iii) Grantee's policy limits may decrease to \$10,000,000 per occurrence for the second and third years following completion of the Work.

2. Commercial auto liability for all owned, hired and non-owned vehicles brought onto Owner's premises with combined single limits of not less than \$1,000,000 per occurrence
3. Worker's Compensation insurance as required by the State in which the Work is being performed
4. Employer's liability insurance on all employees, for occupational accidents or disease, with limits of not less than \$1,000,000 per occurrence. In the States of Washington and Ohio (or other so-called Monopolistic States), such coverage to be provided through a Stop Gap Liability Endorsement to the Commercial General Liability Policy
5. Equipment and Personal Property insurance adequate to cover the value of all tools and equipment, including rentals, used in performing the Work
6. Any other insurance required by applicable federal state, or local laws

In each policy of insurance described above, **Grantee** must be the named insured. **Grantee** shall name Owner, ERP Operating Limited Partnership, Equity Residential, Equity Residential Management, L.L.C., ERP Holding Co., Inc., their affiliates and agents (including the owner of any individual property) as Additional Insureds under the policies required in clauses 1, 2 & 4 above. All policies shall provide for (i) at least thirty (30) days written notice to **Grantee** and Owner prior to cancellation, and (ii) at least ten (10) days written notice to Grantee and Owner for cancellation due to non-payment of applicable premiums. All policies of insurance shall contain full Waivers of Subrogation in favor of Owner and related parties and must not contain Exclusions for Work performed on Residential properties. Grantee's insurance coverage shall be primary insurance with respect to any other insurance or self-insurance programs maintained by Owner related parties, and such other insurance or self-insurance programs shall be excess and non-contributory. **Grantee** shall deliver to Owner a certificate of insurance the coverage provided by each policy and provide replacement certificates fifteen (15) days prior to the expiration of any required coverage.

Insurance policies shall not have deductibles or self-insurance retentions greater than \$100,000 unless approved in writing by Owner. Notwithstanding anything to the contrary herein, **Grantee**, at its sole cost and expense, shall be responsible for the payment of any deductibles or retentions associated with the insurance set forth in these requirements, without reimbursement from Owner.

**Grantee** shall fully cooperate with Owner in connection with any claim against Owner that is in whole or in part caused by **Grantee**, its Contractor or any of its Subcontractors.

**5. NOTICES** Any notice required or permitted hereunder shall be in writing and shall be deemed to have been received either (a) when delivered by hand and the party giving such notice has received a signed receipt thereof, or (b) one business day after the date deposited with a nationally recognized overnight courier service (e.g., Federal Express) addressed as follows (or addressed in such other manner as the party being notified shall have requested by written notice to the other party):

If to Grantor:

ERP Operating Limited Partnership  
 c/o Equity Residential  
 6100 Center Drive, Suite 750  
 Los Angeles, CA 90045  
 Attention: Julio Morales, Vice President - Investments

With a copy to:  
 ERP Operating Limited Partnership  
 c/o Equity Residential  
 Two North Riverside Plaza, Suite 400  
 Chicago, 60606-2639

Attention: General Counsel

If to Grantee: Las Virgenes Municipal Water District  
4232 Las Virgenes Road  
Calabasas, California 91302  
Attention: Eric Maple

**6. REMEDIES AND ENFORCEMENT.**

(a) All and Equitable Remedies Available In the event of a breach or threatened breach by any party of any of the terms, covenants, restrictions or conditions hereof, the other party shall be entitled forthwith to adequate relief by injunction and all such other available legal and equitable remedies from the consequences of such breach, including payment of any amounts due specific performance.

(b) Remedies Cumulative The remedies specified herein shall be cumulative and in addition to all other remedies permitted at law or in equity.

**7. MISCELLANEOUS.**

(a) Attorneys' Fees In the event a party institutes any legal action or proceeding for the enforcement of any right or obligation herein contained, the prevailing party after a final adjudication shall be entitled to recover its costs and reasonable attorneys' fees incurred in the preparation and prosecution of such action or proceeding

(b) Recording; Amendment This Agreement will not be recorded until such time as the Grantee Improvements have been completed and the Exhibits contemplated for the Permanent Easement Area have been completed and attached hereto. At such time, Grantee may request Grantor to record this Agreement at Grantee's expense, whereupon Grantor will provide a copy of the recorded document to Grantee. The parties agree that the provisions of this Agreement may be modified or amended, in whole or in part, or terminated, only by the written consent of both Grantor and Grantee, evidenced by a document that has been fully executed and acknowledged by both Grantor and Grantee and recorded in the official records of Los Angeles County, California.

(c) No Waiver No waiver of any default of any obligation by any party hereto shall be implied from any omission by the other party to take any action with respect to such default

(d) No Agency Nothing in this Agreement shall deemed or construed by either party or by any third person to create the relationship of principal and agent or of limited or general partners or of joint venturers or of any other association between the parties

(e) Covenants to Run with Land It is intended that each of the easements, covenants, conditions, restrictions, rights and obligations set forth herein shall run with the land and create equitable servitudes in favor of the real property benefited thereby, shall bind every person having any fee, leasehold or other interest therein and shall inure to the benefit of the respective parties and their successors, assigns, heirs, personal representatives

(g) Separability Each provision of this Agreement and the application thereof to Grantor's Property and Grantee's Property are hereby declared to be independent of and severable from the remainder of this Agreement. If any provision contained herein shall be held to be invalid or to be unenforceable or not to run with the land, such holding shall not affect the validity or enforceability of the remainder of this Agreement. In the event the validity or enforceability of any provision of this Agreement is held to be dependent upon the existence of a specific legal description, the parties agree to promptly cause such legal description to be prepared.

(h) Time of Essence Time is of the essence of this Agreement.

(i) Entire Agreement This Agreement contains the complete understanding and agreement of the parties hereto with respect to all matters referred to herein, and all prior representations, negotiations, and understandings are hereby superseded.

(j) Counterparts This Agreement may be executed in counterparts, which, when taken together, shall constitute one Agreement. However, this Agreement shall not be effective unless and until all counterpart signatures have been obtained.

(k) Governing Law. This Agreement shall be governed by, construed in accordance with, and interpreted under the law of the State of California.

IN WITNESS WHEREOF, the Grantor and Grantee have executed this Agreement by their duly authorized representatives, to be effective as of the day and year first above written

GRANTOR:

**ERP OPERATING LIMITED PARTNERSHIP**, an Illinois limited partnership

By: Equity Residential, a Maryland real estate investment trust, its general partner

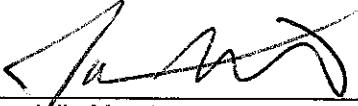
By:   
Name: Julio Morales  
Title: Vice President

GRANTEE:

**LAS VIRGENES WATER DISTRICT**, a California quasi-municipal Corporation

By: \_\_\_\_\_  
Name: \_\_\_\_\_  
Title: \_\_\_\_\_

**EXHIBIT A**

**GRANTOR'S PROPERTY**

THAT PORTION OF SECTION 1, TOWNSHIP 2 NORTH, RANGE 17 WEST, SAN BERNARDINO MERIDIAN, IN THE COUNTY OF LOS ANGELES, STATE OF CALIFORNIA, ACCORDING TO THE OFFICIAL PLAT THEREOF, DESCRIBED AS FOLLOWS:

BEGINNING AT A POINT IN THE EAST LINE OF SAID SECTION, DISTANT THEREON SOUTH 0 DEGREES 12 MINUTES 28 SECONDS WEST 653.42 FEET FROM THE NORTHEAST CORNER; THENCE

NORTH 89 DEGREES 47 MINUTES 32 SECONDS WEST 693.39 FEET; THENCE NORTH 7 DEGREES 56 MINUTES 38 SECONDS WEST 507.61 FEET TO THE TRUE POINT OF BEGINNING OF THIS DESCRIPTION; THENCE SOUTH 57 DEGREES 43 MINUTES 55 SECONDS WEST 58.31 FEET; THENCE NORTH 80 DEGREES 10 MINUTES 59 SECONDS WEST 17.42 FEET; THENCE SOUTH 74 DEGREES 24 MINUTES 43 SECONDS WEST 123.73 FEET; THENCE SOUTH 19 DEGREES 42 MINUTES 09 SECONDS WEST 45.29 FEET; THENCE SOUTH 80 DEGREES 38 MINUTES 16 SECONDS WEST 29.00 FEET; THENCE NORTH 48 DEGREES 38 MINUTES 12 SECONDS WEST 47.40 FEET; THENCE SOUTH 77 DEGREES 31 MINUTES 42 SECONDS WEST 266.03 FEET TO A POINT IN THE EASTERLY BOUNDARY LINE OF PARCEL 1, AS DESCRIBED IN THE DEED RECORDED OCTOBER 25, 1965 AS INSTRUMENT NO. 874 IN BOOK D-3091 PAGE 856 OF OFFICIAL RECORDS OF SAID COUNTY; THENCE NORTH 0 DEGREES 59 MINUTES 06 SECONDS EAST 314.97 FEET, MORE OR LESS, ALONG SAID LAST MENTIONED EASTERLY BOUNDARY LINE TO A POINT IN THE NORTHERLY BOUNDARY LINE OF SAID SECTION; THENCE NORTH 89 DEGREES 27 MINUTES 08 SECONDS EAST 549.43 FEET, MORE OR LESS, TO A LINE WHICH BEARS SOUTH 7 DEGREES 33 MINUTES 19 SECONDS EAST AND WHICH PASSES THROUGH THE TRUE POINT OF BEGINNING OF THIS DESCRIPTION; THENCE ALONG SAID LINE SOUTH 7 DEGREES 33 MINUTES 19 SECONDS EAST TO THE TRUE POINT OF BEGINNING.

**EXHIBIT B**  
**EASEMENT AREA**

**LEGAL DESCRIPTION**

Being a strip of land, 40.00 feet wide, in the unincorporated territory of the County of Los Angeles, State of California, over a portion of Lot 5 of Tract No. 34108, as shown on the Map filed in Book 1070, Pages 92 through 99, inclusive of Maps, in the office of the County Recorder of Los Angeles County, the centerline of said strip of land described as follows:  
Beginning at a point in the northwesterly line of said Lot 5, said point bears North 65°37'39" East 903.34 feet from the northwesterly corner of said Lot; thence,  
1st: South 6°09'39" West 18.10 feet; thence,  
2nd: South 16°20'21" East 107.28 feet; thence,  
3rd: South 5°05'21" East 66.93 feet; thence,  
4th: South 50°05'21" East 75.65 feet; thence,  
5th: South 5°05'21" East 148.82 feet; thence,  
6th: South 50°05'21" East 68.86 feet; thence,  
7th: South 72°35'21" East 60.34 feet to the intersection with the southerly line of said Lot 5, being also the northerly line of State Highway 118, shown on said Tract Map as "Simi Valley – San Fernando Valley Freeway".  
The sidelines of said strip of land to be lengthened or shortened to terminate northerly and southerly in the boundary of said Lot 5.

**EXHIBIT C**  
**EASEMENT AREA GRAPHIC**



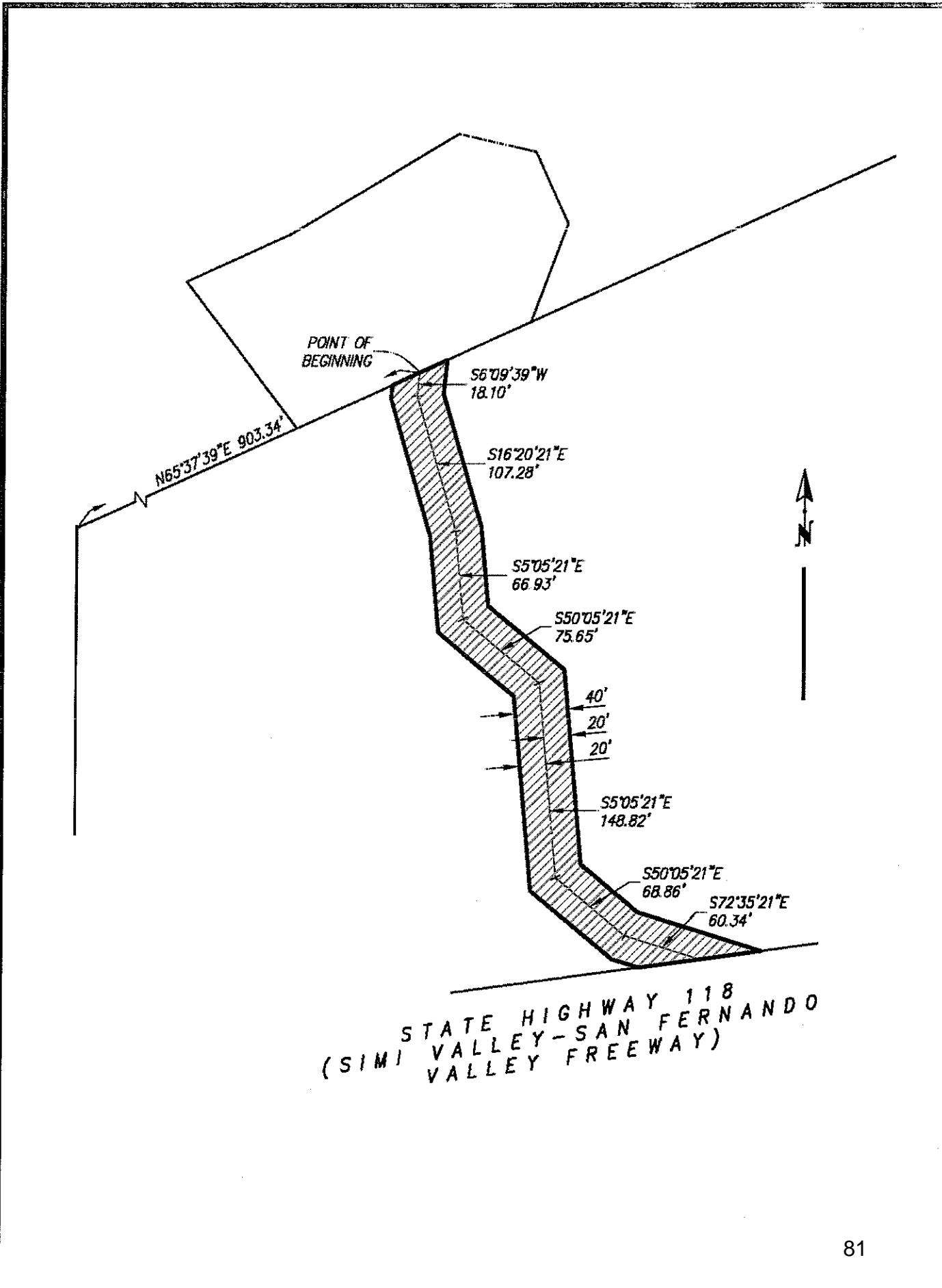

REF :  
15186  
LOT 1  
DWG  
DATE :  
12/22/2015

TWIN  
LAK  
EST  
ANK  
SITE

SCALE 1=100'

LOT 5  
TRACT No  
34108

PREPARED BY:  
BENNER AND CARPENTER, INC.  
506 EAST MAIN STREET SANTA PAULA, CA 93060 (805) 525-3396

**SKETCH TO ACCOMPANY LEGAL DESCRIPTION**

# Notice of Exemption

Form D

**To:** Office of Planning and Research  
P.O. Box 3044, Room 212  
Sacramento, CA 95812-3044

**From:** (Public Agency) \_\_\_\_\_

County Clerk  
County of \_\_\_\_\_

\_\_\_\_\_  
\_\_\_\_\_  
(Address)

Project Title: \_\_\_\_\_

Project Location - Specific: \_\_\_\_\_

Project Location – City: \_\_\_\_\_ Project Location – County: \_\_\_\_\_

Description of Nature, Purpose and Beneficiaries of Project: \_\_\_\_\_

Name of Public Agency Approving Project: \_\_\_\_\_

Name of Person or Agency Carrying Out Project: \_\_\_\_\_

Exempt Status: **(check one)**

Ministerial (Sec. 21080(b)(1); 15268);

Declared Emergency (Sec. 21080(b)(3); 15269(a));

Emergency Project (Sec. 21080(b)(4); 15269(b)(c));

Categorical Exemption. State type and section number: \_\_\_\_\_

Statutory Exemptions. State code number: \_\_\_\_\_

Reasons why project is exempt: \_\_\_\_\_

Lead Agency

Contact Person: \_\_\_\_\_ Area Code/Telephone/Extension: \_\_\_\_\_

**If filed by applicant:**

1. Attach certified document of exemption finding.

2. Has a Notice of Exemption been filed by the public agency approving the project?      Yes      No

Signature: \_\_\_\_\_ Date: \_\_\_\_\_ Title: \_\_\_\_\_

Signed by Lead Agency

Date received for filing at OPR: \_\_\_\_\_

Signed by Applicant

Revised 2005