



LAS VIRGENES MUNICIPAL WATER DISTRICT
4232 Las Virgenes Road, Calabasas, CA 91302

AGENDA
REGULAR MEETING

Members of the public wishing to address the Board of Directors are advised that a statement of Public Comment Protocols is available from the Clerk of the Board. Prior to speaking, each speaker is asked to review these protocols and **MUST** complete a speakers' card and hand it to the Clerk of the Board. Speakers will be recognized in the order cards are received.

The **Public Comments** agenda item is presented to allow the public to address the Board on matters not on the agenda. The public may present comments on any agenda item at the time the item is called upon for discussion.

Materials prepared by the District in connection with subject matter on the agenda are available for public inspection at 4232 Las Virgenes Road, Calabasas, CA 91302. Materials prepared by the District and distributed to the Board during this meeting are available for public inspection at the meeting or as soon thereafter as possible. Materials presented to the Board by the public will be maintained as part of the records of these proceedings and are available upon written request to the Clerk of the Board.

5:00 PM

April 26, 2016

PLEDGE OF ALLEGIANCE

- 1 **CALL TO ORDER AND ROLL CALL**
- 2 **APPROVAL OF AGENDA**
- 3 **PUBLIC COMMENTS**

Members of the public may now address the Board of Directors **ON MATTERS NOT APPEARING ON THE AGENDA**, but within the jurisdiction of the Board. No action shall be taken on any matter not appearing on the agenda unless authorized by Subdivision (b) of Government Code Section 54954.2

4 **CONSENT CALENDAR**

A **List of Demands: April 26, 2016 (Pg. 4)**

Approve

B **Minutes: Regular Meeting of April 12, 2016 (Pg. 33)**

Approve

C **Cash and Investment Report for March 2016 (Pg. 43)**

Receive and file the Cash and Investment Report for March 2016.

5 **ILLUSTRATIVE AND/OR VERBAL PRESENTATION AGENDA ITEMS**

A **Legislative and Regulatory Updates**

B **Water Supply Conditions and Drought Response (Pg. 55)**

6 **TREASURER**

7 **FACILITIES AND OPERATIONS**

A **Las Virgenes-Calleguas Interconnection Project: Memorandum of Understanding for Proposition 84 Integrated Regional Water Management Program Implementation Grant (Pg. 65)**

Authorize the General Manager to execute a Memorandum of Understanding with the Los Angeles County Flood Control District, in a form approved by District Legal Counsel, for a Proposition 84 Integrated Regional Water Management Program Implementation Grant for the Las Virgenes-Calleguas Interconnection Project.

B **Replacement of Construction Service Truck: Purchase Orders (Pg. 93)**

Authorize the General Manager to issue purchase orders to Velocity Truck Centers of Oxnard/Los Angeles Truck Centers, LLC, in the amount of \$89,979.48, for a Freightliner M2 106 Cab and Chassis, and Skaug Truck Body Works of San Fernando, in the amount of \$41,724.98, for the purchase and installation of a custom-matched utility body; and declare Vehicle No. 136 as surplus equipment for salvage.

C **Lost Hills Interchange 10-inch Recycled Water Main Relocation Project: Change Order No. 1 (Pg. 98)**

Authorize the General Manager to approve Change Order No. 1, in the amount of \$121,918.72, for the Lost Hills Interchange 10-inch Recycled Water Main Relocation Project.

8 **RESOURCE CONSERVATION AND PUBLIC OUTREACH**

A **Proposed Policy for Temporary Meter Service (Pg. 108)**

Approve the proposed Policy for Temporary Meter Service.

9 **INFORMATION ITEMS**

A **Saddletree Tank Rehabilitation Project: Change Order No. 1 (Pg. 111)**

10 **NON-ACTION ITEMS**

A **Organization Reports**

(1) MWD Representative Report

(2) Other

B **Director's Reports on Outside Meetings**

C **General Manager Reports**

(1) General Business

(2) Follow-Up Items

D **Director's Comments**

11 **FUTURE AGENDA ITEMS**

12 **PUBLIC COMMENTS**

Members of the public may now address the Board of Directors **ON MATTERS NOT APPEARING ON THE AGENDA**, but within the jurisdiction of the Board. No action shall be taken on any matter not appearing on the agenda unless authorized by Subdivision (b) of Government Code Section 54954.2

13 **CLOSED SESSION**

A **Conference with District Counsel – Existing Litigation (Government Code Section 54956.9(a)):**

1. Las Virgenes - Triunfo Joint Powers Authority v. United States Environmental Protection Agency and Heal the Bay, Inc. v. Lisa P. Jackson (TMDL cases)
2. Las Virgenes - Triunfo Joint Powers Authority v. United States Environmental Protection Agency (FOIA case)

B **Conference with District Counsel – Public Employee Performance Evaluation (Government Code Section 54957):**

Title: General Manager

14 **OPEN SESSION AND ADJOURNMENT**

Pursuant to Section 202 of the Americans with Disabilities Act of 1990 (42 U.S.C. Sec. 12132), and applicable federal rules and regulations, requests for a disability-related modification or accommodation, including auxiliary aids or services, in order to attend or participate in a meeting, should be made to the Executive Assistant/Clerk of the Board in advance of the meeting to ensure availability of the requested service or accommodation. Notices, agendas, and public documents related to the Board meetings can be made available in appropriate alternative format upon request.

LAS VIRGENES MUNICIPAL WATER DISTRICT

To: JAY LEWITT, TREASURER

Payments for Board Meeting of: April 26, 2016

Upon certification by the Treasurer the checks and wire transfers were correct and supporting documents available, it is recommended the following demands on the various funds be approved and payments authorized.

Wells Fargo Bank A/C No. 4806-994448

Checks Nos. 72703 through 72836 were issued in the total amount of \$ 744,379.83

Payments through wire transfers as follows:

None

Total payments \$ 744,379.83

(Reference is hereby made to these demands on file in the District's Check Register and by this reference the same is incorporated herein and made a part hereof.)

**CHECK LISTING FOR BOARD MEETING
04/26/16**

Company Name	Company No.	Check No.	Check No.	Check No.	Total
		72703 thru 72721 04/12/16	72722 thru 72740 04/19/16	72741 thru 72836 04/26/16	
		Amount	Amount	Amount	
Potable Water Operations	101	65,279.43	4,364.70	69,030.30	138,674.43
Recycled Water Operations	102	348.25			348.25
Sanitation Operations	130	4,701.51	1,617.67	1,937.00	8,256.18
Potable Water Construction	201				0.00
Water Conservation Construction	203				0.00
Potable Water Replacement	301	5,323.21	9,100.00	50,847.41	65,270.62
Reclaimed Water Replace	302				0.00
Internal Service	701	20,556.35	28,729.86	69,769.02	119,055.23
JPA Operations	751	95,522.25	32,264.15	100,389.37	228,175.77
JPA Construction	752			16,020.20	16,020.20
JPA Replacement	754			172,852.36	172,852.36
Total Printed		191,731.00	76,076.38	480,845.66	748,653.04
Voided Checks / payment stopped:					
Ck#72685	101	(3,484.00)			(3,484.00)
Ck#71603	701	(789.21)			(789.21)
Total Voids		(4,273.21)	0.00	0.00	(4,273.21)
Net Total		187,457.79	76,076.38	480,845.66	744,379.83

Batch Number -	243983	Bank Account -	00146807	Cash-General	Las Virgenes Municipal Water APV Auto Payment Register					
Payment Number	Payment Date	Address Number	Name	Payment Stub Message	Document Ty	Document Number	Key Item	Key Co	Amount	Invoice Number
72703	04/12/16	16051	ACCURATE TELECOM INC.	REDUNDT MITEL PHN CNTRLR	PV	145281	001	00701	5,323.21	15901
72704	04/12/16	7965	B&B PALLET CO.	REDUNDT MITEL PHN CNTRLR Payment Amount	PV	145286	001	00701	2,500.00	15902
				55 YDS WOOD CHIPS	PV	145249	001	00701	638.00	114912
				55 YDS WOOD CHIPS	PV	145250	001	00701	638.00	114913
72705	04/12/16	6680	CHATEAU PARK HOA	CLAIM-LATERAL LN 10/22/15 Payment Amount	PV	145255	001	00701	144.41	CLAIM102215
72706	04/12/16	9244	CHEMTRADE CHEMICALS US LLC	11.62 TN.ALUM SULFATE	PV	145248	001	00701	3,137.40	91776070
				DEPT #771807, P. O. BOX 77000 DETROIT MI 48277-1807						
72707	04/12/16	17918	EARTHLINK BUSINESS CO.	APR'16 MPLS LINES	PV	145258	001	00701	4,286.95	1318062504011 60
72708	04/12/16	2658	FEDERAL EXPRESS CORP	1 PKG DEL 3/23/16	PV	145254	001	00701	7.17	5-370-20308
72709	04/12/16	20146	FUSIONSTORM	JUNIPR SWITCH	PV	145244	001	00701	562.50	INV275088
72710	04/12/16	6770	G.I. INDUSTRIES	3/16-3/28/16 RLV DISP 4/16 SHOP&HQ DISP 4/16 WLK DISP 4/16 RLV DISP	PV	145325	001	00701	224.18	2766538-0283-1
					PV	145326	001	00701	626.90	2766665-0283-2
					PV	145327	001	00701	236.04	2411974-0283-7
					PV	145328	001	00701	85.08	2766663-0283-7
					PV	145330	001	00701	686.40	2525943-0283-5
					PV	145331	001	00701	633.65	2525942-0283-

Batch Number - 243983
Bank Account - 00146807 Cash-General

Payment Number	Payment Date	Address Number	Name	Payment Stub Message	Ty	Document Number	Key	Amount	Invoice Number
				DISP					7
				4/16 RLV FARM	PV	145332	001 00701	85.08	2766664-0283-
				DISP					5
				Alt Payee 6771 G.I. INDUSTRIES P. O. BOX 541065 LOS ANGELES CA 90054-1065					
				Payment Amount 2,577.33					
72711	04/12/16	20318	ROBERT GLASSON	MILEAGE-WNDRW	PV	145253	001 00701	92.88	021116
				R TRNG					
				2/7~11/16					
				Payment Amount 92.88					
72712	04/12/16	18862	MALIBU CANYON APTS	REFUND-INCOR	PV	145302	001 00101	2,341.55	048163-500721
				PMTS APL					
				Payment Amount 2,341.55					
72713	04/12/16	2814	MCMaster-CARR SUPPLY CO	VEH#911 TOOLS	PV	145279	001 00701	1,058.93	54041573
				Alt Payee 3197 MC MASTER-CARR P. O. BOX 7690 CHICAGO IL. 60680-7690					
				Payment Amount 1,058.93					
72714	04/12/16	20329	SHARLEEN SCHWARTZ	TURF RMVL	PV	145179	001 00101	3,484.00	850082
				REBATE					
				Payment Amount 3,484.00					
72715	04/12/16	19169	SJM INDUSTRIAL RADIO	MOTROLA	PV	145251	001 00701	948.30	229584
				SL7550&CHRGR					
				Payment Amount 15.00					
				FREIGHT					
				MARS RADIO					
				SVC RPR					
				PTT PAD,					
				BEZEL&BATT					
				CVR					
				BATTERY CVR,					
				BELT CLIP&MAH					
				BATT					
				Payment Amount 88.48					
				VEH#8238850					
				RADIO RPR					
				VEH#7148892					
				RADIO RPR					
				Payment Amount 529.64					
				VEH#801,802,8					
				RADIO RPR					
				Payment Amount 769.64					
				RADIO RPR					
				Payment Amount 769.64					

Batch Number - 243983

Bank Account - 00146807 Cash-General

Payment Number	Payment Date	Address Number	Name	Payment Stub Message	Ty	Document Number	Key	Key	Co	Amount	Invoice Number
				11,868 RADIO							
				RPR							
				VEH#814,870,3	PV	145300	001	00701		723.86	229716
				17 RADIO RPR							
				Payment Amount					4,419.56		
72716	04/12/16	2957	SOUTHERN CALIFORNIA EDISON	ENERGY-MAR'16	PV	145278	001	00101		2,224.79	2869/040516
				ENERGY-MAR'16	PV	145278	002	00101		26.25	2869/040516
				ENERGY-MAR'16	PV	145278	003	00101		313.71	2869/040516
				ENERGY-MAR'16	PV	145278	004	00101		25.08	2869/040516
				ENERGY-MAR'16	PV	145278	005	00101		25.08	2869/040516
				ENERGY-MAR'16	PV	145278	006	00101		69.20	2869/040516
				ENERGY-MAR'16	PV	145278	007	00101		18.95	2869/040516
				ENERGY-MAR'16	PV	145278	008	00101		16.25	2869/040516
				ENERGY-MAR'16	PV	145278	009	00101		10.84	2869/040516
				ENERGY-MAR'16	PV	145278	010	00101		25.08	2869/040516
				ENERGY-MAR'16	PV	145278	011	00101		28.68	2869/040516
				ENERGY-MAR'16	PV	145278	012	00101		26.25	2869/040516
				ENERGY-MAR'16	PV	145278	013	00101		2,174.33	2869/040516
				ENERGY-MAR'16	PV	145278	014	00101		4,695.13	2869/040516
				ENERGY-MAR'16	PV	145278	015	00101		52.42	2869/040516
				ENERGY-MAR'16	PV	145278	016	00101		3,517.54	2869/040516
				ENERGY-MAR'16	PV	145278	017	00101		6,308.67	2869/040516
				ENERGY-MAR'16	PV	145278	018	00101		24.76	2869/040516
				ENERGY-MAR'16	PV	145278	019	00101		91.31	2869/040516
				ENERGY-MAR'16	PV	145278	020	00101		3,271.62	2869/040516
				ENERGY-MAR'16	PV	145278	021	00101		12,764.25	2869/040516
				ENERGY-MAR'16	PV	145278	022	00101		51,056.98	2869/040516
				ENERGY-MAR'16	PV	145278	023	00101		27.53	2869/040516
				ENERGY-MAR'16	PV	145278	024	00101		670.05	2869/040516
				ENERGY-MAR'16	PV	145278	025	00101		811.85	2869/040516
				ENERGY-MAR'16	PV	145278	026	00101		4,586.55	2869/040516
				ENERGY-MAR'16	PV	145278	027	00101		378.19	2869/040516
				ENERGY-MAR'16	PV	145278	028	00101		241.92	2869/040516
				ENERGY-MAR'16	PV	145278	029	00101		582.14	2869/040516
				ENERGY-MAR'16	PV	145278	030	00101		2,234.91	2869/040516
				ENERGY-MAR'16	PV	145278	031	00101		28.28	2869/040516
				ENERGY-MAR'16	PV	145278	032	00101		1,218.86	2869/040516
				ENERGY-MAR'16	PV	145278	033	00101		29.72	2869/040516
				ENERGY-MAR'16	PV	145278	034	00101		266.61	2869/040516

Las Virgenes Municipal Water
 A/P Auto Payment Register

Batch Number - 243983
 Bank Account - 00146807 Cash-General

Payment Number	Payment Date	Address Number	Name	Payment Stub Message	Ty	Document Number	Key Item	Co	Amount	Invoice Number
				ENERGY-MAR'16	PV	145278	035	00101	27.27	2869/040516
				ENERGY-MAR'16	PV	145278	036	00101	5,065.76	2869/040516
				ENERGY-MAR'16	PV	145278	037	00101	2,338.33	2869/040516
				ENERGY-MAR'16	PV	145278	038	00101	5,287.22	2869/040516
				ENERGY-MAR'16	PV	145278	039	00101	1,980.57	2869/040516
				ENERGY-MAR'16	PV	145278	040	00101	1,403.73	2869/040516
				ENERGY-MAR'16	PV	145278	041	00101	2,527.18	2869/040516
				ENERGY-MAR'16	PV	145278	042	00101	8,654.56	2869/040516
				ENERGY-MAR'16	PV	145278	043	00101	2,454.26	2869/040516
				ENERGY-MAR'16	PV	145278	044	00101	2,990.74	2869/040516
				ENERGY-MAR'16	PV	145278	045	00101	73.73	2869/040516
				ENERGY-MAR'16	PV	145278	046	00101	341.42	2869/040516
				ENERGY-MAR'16	PV	145278	047	00101	141.54	2869/040516
				ENERGY-MAR'16	PV	145278	048	00101	45.04	2869/040516
				ENERGY-MAR'16	PV	145278	049	00101	676.99	2869/040516
				ENERGY-MAR'16	PV	145278	050	00101	1,356.38	2869/040516
				ENERGY-MAR'16	PV	145278	051	00101	3,162.27	2869/040516
				ENERGY-MAR'16	PV	145278	052	00101	25.08	2869/040516
				ENERGY-MAR'16	PV	145278	053	00101	28.43	2869/040516
				ENERGY-MAR'16	PV	145278	054	00101	27.15	2869/040516
				ENERGY-MAR'16	PV	145278	055	00101	77.08	2869/040516
				ENERGY-MAR'16	PV	145278	056	00101	29.03	2869/040516
				ENERGY-MAR'16	PV	145278	057	00101	567.04	2869/040516
				ENERGY-MAR'16	PV	145278	058	00101	14.00	2869/040516
				ENERGY-MAR'16	PV	145278	059	00101	13.99	2869/040516
				ENERGY-MAR'16	PV	145278	060	00101	334.26	2869/040516
				ENERGY-MAR'16	PV	145278	061	00101	32.67	2869/040516
				ENERGY-MAR'16	PV	145278	062	00101	327.81	2869/040516
				ENERGY-MAR'16	PV	145278	063	00101	2,158.75	2869/040516
				ENERGY-MAR'16	PV	145278	064	00101	1,249.77	2869/040516
				ENERGY-MAR'16	PV	145278	065	00101	624.89	2869/040516
				Payment Amount				141,880.72		
72717	04/12/16	2957	SOUTHERN CALIFORNIA EDISON	RLV COMPST	PV	145280	001	00751	17,578.80	5165-46/04051
				PLNT						6
				3/2-4/1/16						
				Payment Amount				17,578.80		
				CONDUIT	PV	145246	001	00101	14.30	8400/040116
				2/24-3/24/16						
				Payment Amount				14.30		
72719	04/12/16	8645	SOUTHERN CALIFORNIA GAS CO	ANIV GIFTS-3	PV	145252	001	00701	400.29	030246-16

Batch Number - 243983
 Bank Account - 00146807 Cash-General

Payment Number	Payment Date	Address Number	Name	Payment Stub Message	Ty	Document Number	Key Item	Co	Amount	Invoice Number
EMPLOYEES										
72720	04/12/16	19135	CALIFORNIA TROPHY COMPANY	Payment Amount ONLN SRCH BAD DBT-3/16	PV	145245	001	00701	400.29 123.00	974571/MAR16
72721	04/12/16	2780	RISK & ALTERNATIVE DATA SOLUT VALLEY NEWS GROUP	Payment Amount AD-MWD SHUTDOWN 3/31/16 AD-REDESIGN GARDN 3/24/16	PV	145256	001	00101	210.00 310.00	3-31 3-25
									520.00	
Total Amount of Payments Written									191,731.00	
Total Number of Payments Written									19	

Batch Number - 244139
 Bank Account - 00146807 Cash-General

Payment Number	Payment Date	Address Number	Name	Payment Stub Message	Document Ty	Document Num	Key Item	Key Co	Amount	Invoice Number
72722	04/19/16	8560	ADVANCED UTILITY SYSTEMS	CIS BDGT BSD RTE PROGRAMG	PV	145361	001	00701	9,100.00	XT00112615
									9,100.00	
72723	04/19/16	2869	AT&T	SRV 4/5-5/4/16	PV	145434	001	00701	543.30	9065/040516
				SRV 4/5-5/4/16	PV	145435	001	00101	109.85	9054/040516
				SRV 4/7-5/6/16	PV	145436	001	00101	33.29	0124/040716
				SRV 4/7-5/6/16	PV	145437	001	00101	67.60	0123/040716
				SRV 4/5-5/4/16	PV	145438	001	00701	543.67	9268/040516
				SRV 4/7-5/6/16	PV	145439	001	00701	85.81	7721/040716
				SRV 4/7-5/6/16	PV	145440	001	00701	117.71	7720/040716
				SRV 4/7-5/6/16	PV	145441	001	00701	117.71	7719/040716
				SRV 4/7-5/6/16	PV	145442	001	00130	101.19	2220/040716
				SRV 4/7-5/6/16	PV	145443	001	00101	408.83	2043/040716
				SRV 4/7-5/6/16	PV	145444	001	00101	202.38	2045/040716
				SRV 4/5-5/4/16	PV	145446	001	00101	20.12	0051/040516
				SRV 4/5-5/4/16	PV	145446	002	00101	263.79	0051/040516
				SRV 4/5-5/4/16	PV	145446	003	00101	103.54	0051/040516
				SRV 4/5-5/4/16	PV	145446	004	00101	117.46	0051/040516
				SRV 4/5-5/4/16	PV	145446	005	00101	1,073.43	0051/040516
				SRV 4/5-5/4/16	PV	145446	006	00101	6,511.48	0051/040516
				SRV 4/5-5/4/16	PV	145446	007	00101	1,264.99	0051/040516
				SRV 4/5-5/4/16	PV	145446	008	00101	101.61	0051/040516

Batch Number - 244139
Bank Account - 00146807 Cash-General

Payment Number	Payment Date	Address Number	Name	Payment Stub Message	Document Number	Key Item	Key Co	Amount	Invoice Number
	4/5-5/4/16								
	SRV			PV	145446	009	00101	83.54	0051/040516
	4/5-5/4/16								
	SRV			PV	145446	010	00101	544.35	0051/040516
	4/5-5/4/16								
	SRV			PV	145446	011	00101	490.98	0051/040516
	4/5-5/4/16								
	SRV			PV	145446	012	00101	1,295.48	0051/040516
	4/5-5/4/16								
	SRV			PV	145446	013	00101	46.69	0051/040516
	4/5-5/4/16								
	SRV			PV	145446	014	00101	101.61	0051/040516
	4/5-5/4/16								
	SRV			PV	145446	015	00101	101.61	0051/040516
	4/5-5/4/16								
	SRV			PV	145446	016	00101	101.82	0051/040516
	4/5-5/4/16								
	SRV			PV	145446	017	00101	101.61	0051/040516
	4/5-5/4/16								
	SRV			PV	145446	018	00101	102.24	0051/040516
	4/5-5/4/16								
	SRV			PV	145446	019	00101	101.61	0051/040516
	4/5-5/4/16								
	SRV			PV	145446	020	00101	101.61	0051/040516
	4/5-5/4/16								
	SRV			PV	145446	021	00101	101.61	0051/040516
	4/5-5/4/16								
	SRV			PV	145446	022	00101	101.61	0051/040516
	4/5-5/4/16								
	SRV			PV	145446	023	00101	101.61	0051/040516
	4/5-5/4/16								
	SRV			PV	145446	024	00101	101.61	0051/040516
	4/5-5/4/16								
	SRV			PV	145446	025	00101	101.61	0051/040516
	4/5-5/4/16								
	SRV			PV	145446	026	00101	101.61	0051/040516
	4/5-5/4/16								
	SRV			PV	145446	027	00101	101.61	0051/040516
	4/5-5/4/16								
	SRV			PV	145446	028	00101	101.61	0051/040516
	4/5-5/4/16								
	SRV			PV	145446	028	00101	101.61	0051/040516

Batch Number - 244139
 Bank Account - 00146807 Cash-General

Payment Number	Payment Date	Address Number	Name	Payment Stub Message	Ty	Document Number	Item	Co	Key	Amount	Invoice Number
				SRV	PV	145446	029	00101		101.61	0051/040516
				4/5-5/4/16							
				SRV	PV	145446	030	00101		105.46	0051/040516
				4/5-5/4/16							
				SRV	PV	145446	031	00101		104.80	0051/040516
				4/5-5/4/16							
				SRV	PV	145446	032	00101		50.80	0051/040516
				4/5-5/4/16							
				SRV	PV	145446	033	00101		50.81	0051/040516
				4/5-5/4/16							
				Payment Amount					16,187.27		
72724	04/19/16	9631	AT&T LONG DISTANCE	LONG DIST	PV	145445	001	00701		560.52	806368136/040416
				3/1-4/1/16							
				LONG DIST	PV	145445	002	00701		3.16	806368136/040416
				3/1-4/1/16							
				LONG DIST	PV	145445	003	00701		20.50	806368136/040416
				3/1-4/1/16							
				LONG DIST	PV	145445	004	00701		.14	806368136/040416
				3/1-4/1/16							
				LONG DIST	PV	145445	005	00701		16.98	806368136/040416
				3/1-4/1/16							
				LONG DIST	PV	145445	006	00701		17.02	806368136/040416
				3/1-4/1/16							
				LONG DIST	PV	145445	007	00701		.04	806368136/040416
				3/1-4/1/16							
				Payment Amount					618.36		
72725	04/19/16	16253	AT&T MOBILITY	SRV	PV	145447	001	00701		235.70	992789332X04112016
				3/4-4/3/16							
				SRV	PV	145447	002	00701		41.50	992789332X04112016
				3/4-4/3/16							
				SRV	PV	145447	003	00701		18.39	992789332X04112016
				3/4-4/3/16							
				SRV	PV	145447	004	00701		452.06	992789332X04112016
				3/4-4/3/16							
				SRV	PV	145447	005	00701		30.96	992789332X04112016
				3/4-4/3/16							
				SRV	PV	145447	006	00701		49.35	992789332X04112016
				3/4-4/3/16							
				SRV	PV	145447	007	00701		60.14	992789332X04112016
				3/4-4/3/16							
				SRV	PV	145447	008	00701		18.39	992789332X04112016
				3/4-4/3/16							

Las Virgenes Municipal Water
 A/P Auto Payment Register

Batch Number - 244139
 Bank Account - 00146807 Cash-General

Payment Number	Payment Date	Address Number	Name	Payment Stub Message	Ty	Document Number	Item	Co	Key	Amount	Invoice Number
				3/4--4/3/16							12016
				SRV	PV	145447	009	00701		12.87	992789332X041
				3/4--4/3/16							12016
				SRV	PV	145447	010	00701		5.52	992789332X041
				3/4--4/3/16							12016
				SRV	PV	145447	011	00701		238.90	992789332X041
				3/4--4/3/16							12016
				SRV	PV	145447	012	00701		225.23	992789332X041
				3/4--4/3/16							12016
				SRV	PV	145447	013	00701		30.96	992789332X041
				3/4--4/3/16							12016
				SRV	PV	145447	014	00701		241.64	992789332X041
				3/4--4/3/16							12016
				SRV	PV	145447	015	00701		18.39	992789332X041
				3/4--4/3/16							12016
				SRV	PV	145447	016	00701		65.63	992789332X041
				3/4--4/3/16							12016
				SRV	PV	145447	017	00701		49.35	992789332X041
				3/4--4/3/16							12016
				SRV	PV	145447	018	00701		61.92	992789332X041
				3/4--4/3/16							12016
				SRV	PV	145447	019	00701		109.95	992789332X041
				3/4--4/3/16							12016
				SRV	PV	145447	020	00701		18.39	992789332X041
				3/4--4/3/16							12016
				SRV	PV	145447	021	00701		65.63	992789332X041
				3/4--4/3/16							12016
				SRV	PV	145447	022	00701		91.29	992789332X041
				3/4--4/3/16							12016
				SRV	PV	145447	023	00701		160.62	992789332X041
				3/4--4/3/16							12016
				Payment Amount						2,302.78	
72726	04/19/16	18982	CDW GOVERNMENT	LINKRUNNER-20	PV	145272	001	00701		1,851.91	CNH9207
				00 NTWK							
			Alt Payee	19010 CDW GOVERNMENT							
				75 REMITTANCE DR., SUITE 1515							
				CHICAGO IL 60675-1515							
				Payment Amount						1,851.91	
72727	04/19/16	2654	FAMCON PIPE	ADPTRS,VLYS,C	PV	145274	001	00701		2,265.02	179061
				LMP,S,ELS,UNIO							

Las Virgenes Municipal Water
 A/P Auto Payment Register

Batch Number - 244139
 Bank Account - 00146807 Cash-General

Payment Number	Payment Date	Address Number	Name	Payment Stub Message	Document Ty	Document Number	Key Item	Key Co	Amount	Invoice Number
72728	04/19/16	2727	IDEXX LABORATORIES		PV	145273	001	00701	1,970.13	3000845674
				Payment Amount					2,265.02	
				COLILERT						
				MEDIA						
				FREIGHT					13.00	3000845674
			Alt Payee	IDEXX LABORATORIES P. O. BOX 101327 ATLANTA GA 30392-1327						
72729	04/19/16	6777	CAL-COAST MACHINERY		PV	145449	001	00751	29.81	315955
				Payment Amount					1,983.13	
				10 MULTI-PRP						
				GREASE						
				JD6320L OIL					543.62	316967
				CHG&SVC						
			Alt Payee	JOHN DEERE FINANCIAL PO BOX 4450 CAROL STREAM IL 60197-4450						
72730	04/19/16	17847	DIAMOND A EQUIPMENT LLC		PV	145451	001	00751	1,776.16	IX68123
				Payment Amount					573.43	
				JD						
				AUGER&PARTS						
				JD AUGER HUB					71.28	IX68123A
				JD MWR					173.20	IX68211
				BLADES&BOLTS						
			Alt Payee	JOHN DEERE FINANCIAL PO BOX 4450 CAROL STREAM IL 60197-4450						
72731	04/19/16	16372	OLIN CORPORATION - CHLOR ALKALI		PV	145289	001	00701	2,703.17	2145673
				Payment Amount					2,020.64	
				4,958 GAL						
				HYPOCHLORITE						
			Alt Payee	OLIN CORPORATION - CHLOR ALKALI P.O. BOX 402766 ATLANTA GA 30384-2766						
72732	04/19/16	2957	SOUTHERN CALIFORNIA EDISON		PV	145277	001	00751	22,549.88	4500-42/04061
				Payment Amount					2,703.17	
				RW P/S						
				3/2-4/1/16						
				NEM						
				Payment Amount					22,549.88	
				RLV						
			Alt Payee	SOUTHERN CALIFORNIA EDISON						
72733	04/19/16	2957	SOUTHERN CALIFORNIA		PV	145433	001	00751	624.25	3293-30/04071
				Payment Amount					624.25	
				COMPOST-DL						
			Alt Payee	SOUTHERN CALIFORNIA EDISON						

Batch Number - 244139

Bank Account - 00146807 Cash-General

Payment Number	Payment Date	Address Number	Name	Payment Stub Message	Ty	Document Number	Key Item	Key Co	Amount	Invoice Number
			EDISON	3/2-4/1/16						
				Payment Amount					624.25	
72734	04/19/16	2958	SOUTHERN CALIFORNIA GAS CO	JBR P/S 3/7-4/5/16	PV	145362	001	00101	14.30	1200/040716
				WLK P/S 3/1-4/1/16	PV	145363	001	00101	368.81	9400/040616
				TAPIA 3/9-4/7/16	PV	145429	001	00751	708.74	4000/041116
				HQ&OPS 3/9-4/7/16	PV	145430	001	00701	1,601.85	3600/041116
				RLV 3/9-4/7/16	PV	145431	001	00751	1,072.58	4200/041116
				CORNELL 3/9-4/7/16	PV	145432	001	00101	16.11	0400/041116
				Payment Amount					3,782.39	
72735	04/19/16	16271	SPOK, INC.	PAGER SRV 3/10-4/10/16	PV	145428	001	00701	339.73	Z0143084D
				PAGER SRV 3/10-4/10/16	PV	145428	002	00701	70.01	Z0143084D
				PAGER SRV 3/10-4/10/16	PV	145428	003	00701	42.02	Z0143084D
				Payment Amount					451.76	
72736	04/19/16	18810	UNIFIRST CORPORATION	3/16 UNIFRMS,MATS/ TWLS@TAPIA	PV	145303	001	00701	45.55	793150
				3/16 UNIFRMS,MATS/ TWLS@TAPIA	PV	145303	002	00701	17.60	793150
				3/16 UNIFRMS,MATS/ TWLS@TAPIA	PV	145304	001	00701	45.55	794738
				3/16 UNIFRMS,MATS/ TWLS@TAPIA	PV	145304	002	00701	47.10	794738
				3/16 UNIFRMS,MATS/ TWLS@TAPIA	PV	145305	001	00701	45.55	796366
				3/16 UNIFRMS,MATS/ TWLS@TAPIA	PV	145305	002	00701	17.60	796366

Payment Number	Date	Address Number	Name	Payment Stub Message	Document Ty Number	Key itm Co	Amount	Invoice Number
3/16				PV UNIFRMS,MATS/ TWLS@TAPIA	145306	001 00701	45.55	797981
3/16				PV UNIFRMS,MATS/ TWLS@TAPIA	145306	002 00701	47.10	797981
3/16				PV UNIFRMS,MATS/ TWLS@TAPIA	145307	001 00701	45.55	799603
3/16				PV UNIFRMS,MATS/ TWLS@TAPIA	145307	002 00701	17.60	799603
3/16				PV UNIFRMS,MATS/ TWLS@TAPIA	145308	001 00701	13.88	793149
3/16				PV UNIFRMS,MATS/ TWLS@WLK	145308	002 00701	6.40	793149
3/16				PV UNIFRMS,MATS/ TWLS@WLK	145310	001 00701	13.88	794737
3/16				PV UNIFRMS,MATS/ TWLS@WLK	145310	002 00701	17.90	794737
3/16				PV UNIFRMS,MATS/ TWLS@WLK	145312	001 00701	13.88	797980
3/16				PV UNIFRMS,MATS/ TWLS@WLK	145312	002 00701	17.90	797980
3/16				PV UNIFRMS,MATS/ TWLS@WLK	145313	001 00701	13.88	799602
3/16				PV UNIFRMS,MATS/ TWLS@WLK	145313	002 00701	6.40	799602
3/16				PV UNIFRMS,MATS/ TWLS@WLK	145314	001 00701	194.50	793152
3/16				PV UNIFRMS,MATS/ TWLS@HQ	145315	001 00701	213.36	794740

Batch Number - 244139
 Bank Account - 00146807 Cash-General

Payment Number	Payment Date	Address Number	Name	Payment Stub Message	Ty	Document Number	Item	Co	Key	Amount	Invoice Number
				TWLS@HQ							
	3/16			UNIFRMS,MATS/	PV	145316	001	00701		192.36	796358
				TWLS@HQ							
	3/16			UNIFRMS,MATS/	PV	145317	001	00701		213.36	797983
				TWLS@HQ							
	3/16			UNIFRMS,MATS/	PV	145318	001	00701		192.36	799605
				TWLS@HQ							
	3/16			UNIFRMS,MATS/	PV	145319	001	00701		23.68	793151
				TWLS@RLV							
	3/16			UNIFRMS,MATS/	PV	145319	002	00701		20.80	793151
				TWLS@RLV							
	3/16			UNIFRMS,MATS/	PV	145320	001	00701		23.68	794739
				TWLS@RLV							
	3/16			UNIFRMS,MATS/	PV	145320	002	00701		30.30	794739
				TWLS@RLV							
	3/16			UNIFRMS,MATS/	PV	145321	001	00701		23.68	796357
				TWLS@RLV							
	3/16			UNIFRMS,MATS/	PV	145321	002	00701		20.80	796357
				TWLS@RLV							
	3/16			UNIFRMS,MATS/	PV	145322	001	00701		23.68	797982
				TWLS@RLV							
	3/16			UNIFRMS,MATS/	PV	145322	002	00701		30.30	797982
				TWLS@RLV							
	3/16			UNIFRMS,MATS/	PV	145323	001	00701		23.68	799604
				TWLS@RLV							
	3/16			UNIFRMS,MATS/	PV	145323	002	00701		20.80	799604
				TWLS@RLV							
	3/16			UNIFRMS,MATS/	PV	145324	001	00701		13.88	796355

Las Virgenes Municipal Water
 A/P Auto Payment Register

Batch Number - 244139
 Bank Account - 00146807 Cash-General

Payment Number	Payment Date	Address Number	Name	Payment Stub Message	Document Ty	Document Number	Key Iltm	Key Co	Amount	Invoice Number
UNIFRMS,MATS/										
TWLS@WLK										
72737	04/19/16	3429	UNITED PARCEL SERVICE	SRV P/E	PV	145324	002	00701	6.40	796365
UNIFRMS,MATS/										
TWLS@WLK										
Payment Amount										
									1,746.49	
72738	04/19/16	16623	VELOCITY TECHNOLOGY SOLUTIONS, INC.	MAY*16	PV	145448	001	00701	55.32	000025W020156
UNIFRMS,MATS/										
TWLS@WLK										
Payment Amount										
									55.32	
72739	04/19/16	3047	WESCO DISTRIBUTION, INC.	FRDM SZ1 O/L	PV	145270	001	00701	3,114.00	312475
UNIFRMS,MATS/										
TWLS@WLK										
Payment Amount										
									3,114.00	
72740	04/19/16	3067	XEROX CORPORATION	LEASE-HQ&TAPI	PV	145271	001	00701	128.53	536400
UNIFRMS,MATS/										
TWLS@WLK										
Payment Amount										
									128.53	
UNIFRMS,MATS/										
TWLS@WLK										
Payment Amount										
									3,816.98	701954818
UNIFRMS,MATS/										
TWLS@WLK										
Payment Amount										
									201.07	084063467
UNIFRMS,MATS/										
TWLS@WLK										
Payment Amount										
									4,018.05	
UNIFRMS,MATS/										
TWLS@WLK										
Payment Amount										
									76,076.38	
UNIFRMS,MATS/										
TWLS@WLK										
Payment Amount										
									19	

Batch Number - 244156

Bank Account - 00146807 Cash-General

Payment Number	Payment Date	Address Number	Name	Payment Stub Message	Document Ty	Document Number	Key Item	Key Co	Amount	Invoice Number
72741	04/26/16	2317	ACORN NEWSPAPER	MAR'16 ADS	PV	145384	001	00751	448.00	870105/033116
				MAR'16 ADS	PV	145384	002	00751	3,006.42	870105/033116
				MAR'16 ADS	PV	145384	003	00751	1,380.54	870105/033116
				LEGAL AD-NTC	PV	145385	001	00701	90.00	M-0579
				OF INT 4/7/16						
				Payment Amount				4,924.96		
72742	04/26/16	19070	ADDISON FOREST PRODUCTS, LLC	80 YDS@\$11 IN 3/16	PV	145365	001	00701	880.00	1264
				Payment Amount				880.00		
72743	04/26/16	20337	SINBAD ADKINS	RFND BAL - CLOSED A/C	PV	145392	001	00101	62.97	000467
				Payment Amount				62.97		
72744	04/26/16	17077	AECOM USA, INC.	2/27-4/1/16 LST HLLS RW	PV	145382	001	00701	377.58	37727405
				Payment Amount				377.58		
72745	04/26/16	2339	AGOURA LOCK TECHNOLOGIES	MISC KEYS	PV	145492	001	00751	23.94	83237
				MISC KEYS	PV	145492	002	00751	181.87	83237
				MISC KEYS	PV	145492	003	00751	112.16	83237
				Payment Amount				317.97		
72746	04/26/16	3077	AIRGAS USA, LLC	GLOVES&SFTY GLASSES	PV	145482	001	00701	880.94	9049866941
				GLOVES&HARD HATS	PV	145483	001	00701	353.99	9049919955
				RUBBER BOOTS	PV	145484	001	00701	391.04	9050199197
				HAND SANITIZERS	PV	145485	001	00701	192.28	9050158700
				Payment Amount				1,918.25		
72747	04/26/16	19717	ALLIED INSURANCE	SURETY BND POLICY 5/16-5/17 JL	PV	145337	001	00701	250.00	910531983/16-17
				Payment Amount				250.00		
72748	04/26/16	20331	CAROLINA ALVARADO	TURF RMVL REBATE	PV	145267	001	00101	3,108.00	630378
				Payment Amount				3,108.00		

Batch Number - 244156
 Bank Account - 00146807 Cash-General

Payment Number	Payment Date	Address Number	Name	Payment Stub Message	TY	Document Number	Key Item	Key Co	Amount	Invoice Number
72749	04/26/16	18955	ARGO CHEMICAL INC.	30,700 LB AMMONIA	PV	145372	001	00701	5,002.72	1604010
				Payment Amount				5,002.72		
72750	04/26/16	16224	ASBURY ENVIRONMENTAL SERVICES	150 GAL USED OIL	PV	145406	001	00751	95.00	1500-00016642
				350 GAL USED OIL	PV	145407	001	00751	95.00	1500-00020885
				55 GAL OIL	PV	145408	001	00751	200.14	1500-00023590
				OIL&ABSORBANT				390.14		
				Payment Amount				390.14		
72751	04/26/16	7965	B&B PALLET CO.	55 YDS WOOD CHIPS	PV	145376	001	00701	638.00	114914
				55 YDS WOOD CHIPS	PV	145377	001	00701	638.00	114915
				55 YDS WOOD CHIPS	PV	145378	001	00701	638.00	114916
				55 YDS WOOD CHIPS	PV	145379	001	00701	638.00	114917
				55 YDS WOOD CHIPS	PV	145380	001	00701	638.00	114918
				55 YDS WOOD CHIPS	PV	145381	001	00701	638.00	114919
				130 YDS WOOD CHIPS	PV	145412	001	00701	1,508.00	114898
				Payment Amount				5,336.00		
72752	04/26/16	18971	BDP INDUSTRIES INC.	SFT SEALS&BSHGS	PV	145369	001	00701	573.77	7942
				Payment Amount				573.77		
72753	04/26/16	20338	MATTHEW BERKE	RFND BAL - CLOSED A/C	PV	145393	001	00101	13.07	033138
				Payment Amount				13.07		
72754	04/26/16	18993	BILLTRUST	3/16 ONLN BILL&PMTS	PV	145479	001	00701	7,714.95	143476
				Payment Amount				7,714.95		
72755	04/26/16	3385	C A RASMUSSEN INC.	RFND BAL - CLOSED A/C	PV	145387	001	00101	552.02	9998442A
				Payment Amount				552.02		
72756	04/26/16	5224	C.E.R.T., INC.	SCBA&FIRE EXTG TRN	PV	145405	001	00701	2,790.00	20160005
				Payment Amount				2,790.00		

Las Virgenes Municipal Water
 A/P Auto Payment Register

Batch Number - 244156
 Bank Account - 00146807 Cash-General

Payment Number	Payment Date	Address Number	Name	Payment Stub Message	Ty	Document Number	Key	Item	Co	Amount	Invoice Number
72757	04/26/16	18739	CALIFORNIA HAZARDOUS SERVICES, INC.	Payment Amount ARP'16 OP SITE VISIT	PV	145264	001	00701		105.00	58717
72758	04/26/16	20335	DAVID CATLIN	Payment Amount TURF RMVL REBATE	PV	145333	001	00101		2,212.00	1110282
72759	04/26/16	20339	ORLANDO CHANDLER	Payment Amount RFND BAL - CLOSED A/C	PV	145394	001	00701		26.45	072385
72760	04/26/16	6632	SANDRA M. CHANDLER	Payment Amount TURF RMVL REBATE	PV	145268	001	00101		692.00	660342/TURF2
72761	04/26/16	18860	CHEMTREAT, INC.	Payment Amount APR'16 WTR TRMT	PV	145454	001	00701		562.71	2217287
72762	04/26/16	2554	COASTLINE EQUIPMENT	Payment Amount JD444K LOADER-RLV	PV	145476	001	00701		163,336.51	292067
72763	04/26/16	19305	COMMERCIAL CLEANING SYSTEMS	Payment Amount APR'16 CLEANG SRV	PV	145341	001	00701		3,525.68	318644
72764	04/26/16	4586	CONSOLIDATED ELECTRICAL DISTRIBUTORS	Payment Amount APR'16 CLEANG SRV	PV	145341	003	00701		464.30	318644
72765	04/26/16	6346	COUNTY OF SAN BERNARDINO HUMAN RESOURCES	Payment Amount GRND STRAP ASSYS	PV	145367	001	00701		196.64	9009-731415
72766	04/26/16	6966	CS-AMSCO	Payment Amount 2 VALVE BODIES	PV	145336	001	00701		1,700.00	032416

Batch Number - 244156
 Bank Account - 00146807 Cash-General

Payment Number	Payment Date	Address Number	Name	Payment Stub Message	Ty	Document Number	Key Item	Key Co	Amount	Invoice Number
72767	04/26/16	2601	DELL COMPUTER CORP	FREIGHT	PV	145368	002	00701	60.60	11155
				Payment Amount					1,150.60	
				DELL ADPTR	PV	145456	001	00701	212.44	XJX35T9C6
				DSP TO DVI	PV	145457	001	00701	12,261.00	XJX3TW839
				DELL OPTIPLEX 3040&MNTR	PV	145457	003	00701	791.53	XJX3TW839
				DELL OPTIPLEX 3040&MNTR	PV	145457	003	00701	791.53	XJX3TW839
				Alt Payee						
			7819 DELL MARKETING LP							
			P.O. BOX 910916							
			PASADENA CA 91110-0916							
				Payment Amount					13,264.97	
72768	04/26/16	2605	DELTA PACIFIC INDUSTRIES	BREAK	PV	145466	001	00701	499.44	4054
				CLNR&EPOXY						
				PUTTY						
				Payment Amount					499.44	
72769	04/26/16	11330	DIAL SECURITY	4/16 SECURITY	PV	145413	001	00701	230.00	272203
				SVC@HQ						
				4/16 SECURITY	PV	145414	001	00701	50.00	272203
				SVC@LOBBY						
				GATES						
				4/16 SECURITY	PV	145415	001	00701	45.00	272204
				SVC@TAPIA						
				4/16 SECURITY	PV	145416	001	00701	80.00	272205
				SVC@RLV						
				4/16 SECURITY	PV	145417	001	00701	35.00	272206
				SVC@RLV-FARM						
				4/16 SECURITY	PV	145418	001	00701	70.00	272207
				SVC@WLK						
				4/16 SECURITY	PV	145419	001	00701	35.00	272208
				SVC@WLK P/S						
				4/16 SECURITY	PV	145420	001	00701	57.00	272209
				SVC@JTRM						
				Payment Amount					602.00	
72770	04/26/16	20340	MARK EGAN	RFND BAL -	PV	145395	001	00101	7.51	058958
				CLOSED A/C						
				Payment Amount					7.51	
72771	04/26/16	14691	EMISSION COMPLIANT CONTROLS	WLK P/S	PV	145364	001	00701	1,570.00	PSO3491
				STARTR RPR						

Las Virgenes Municipal Water
A/P Auto Payment Register

Batch Number - 244156
Bank Account - 00146807 Cash-General

Payment Number	Payment Date	Address Number	Name	Payment Stub Message	Ty	Document Number	Key	Amount	Invoice Number
Number	Date	Number				Number	Item Co		Number
CORP.									
Alt Payee	15750	EMISSION COMPLIANT CONTROLS CORP.							
		P. O. BOX 16727							
		IRVINE CA 92623-6727							
72772	04/26/16	2650	EXPRESS PARTS EXCHANGE	REBLD VEH#647	PV	145386	001 00701	199.80	52299
				STARTIR					
72773	04/26/16	2654	FAMCON PIPE	GRIT PUMP	PV	145375	001 00701	2,762.06	179203
				FITTINGS					
72774	04/26/16	18815	FASTENAL COMPANY	RESTOCK BOLT	PV	145374	001 00701	1,014.91	CACHA21311
Alt Payee	18835	FASTENAL COMPANY							
		P. O. BOX 1286							
		WINONA MN 55987-1286							
72775	04/26/16	2658	FEDERAL EXPRESS CORP	1 PKG DEL	PV	145478	001 00701	86.86	5-385-26423
				4/7/16					
72776	04/26/16	19397	FIRST CHOICE SERVICES	HQ COFFEE	PV	145486	001 00701	76.29	220179
				SUPPLIES					
				OPS COFFEE					
				SUPPLIES					
				RLV COFFEE					
				SUPPLIES					
				TAPIA COFFEE					
				SUPPLIES					
72777	04/26/16	4971	FUGRO CONSULTANTS, INC.	1/22-3/24/16	PV	145263	001 00701	4,158.46	04.62150074-4
				LRNZO CT MNTR					
Alt Payee	6803	FUGRO CONSULTANTS, INC.							
		P. O. BOX 301083							
		DALLAS TX 75303-1083							
72778	04/26/16	18126	GARDENERD	GARDENING	PV	145335	001 00101	515.12	2167
				CLASS@4/6/16					
72779	04/26/16	19454	NOAM GEFT	RFND O/P	PV	145390	001 00101	1,628.45	070652

Las Virgenes Municipal Water
 A/P Auto Payment Register

Batch Number - 244156
 Bank Account - 00146807 Cash-General

Payment Number	Payment Date	Address Number	Name	Payment Stub Message	Ty	Document Number	Key	Amount	Invoice Number
				BAL-OPEN A/C				1,628.45	
72780	04/26/16	2701	GRAINGER, INC.	Payment Amount STEEL MAIL HOUSES HOSE TORCH KIT MOUSE TRAPS MOUSE TRAPS PUMP, CONDENSATE 115V 5/8" CUSHND CLAMPS	PV	145343	001 00751	223.85	9063012521
						145344	001 00751	112.66	9059502899
						145345	001 00751	30.33	9061542289
						145346	001 00751	55.15	9061542297
						145347	001 00701	93.54	9062364204
						145348	001 00751	138.65	9061788403
			Alt Payee 5453 GRAINGER, INC. DEPT 805178142 PALATINE IL 60038-0001	Payment Amount				654.18	
72781	04/26/16	9546	GRAYBAR ELECTRIC CO.	MODICON TAP,DRP&TRMTR	PV	145455	001 00701	434.22	984542270
				Payment Amount				434.22	
72782	04/26/16	19548	GRM INFORMATION MANAGEMENT SERVICES-CA	APR'16 STORAGE	PV	145480	001 00701	115.42	0290967
				APR'16 STORAGE	PV	145481	001 00701	356.28	0290968
				Payment Amount				471.70	
72783	04/26/16	18646	HDR ENGINEERING, INC.	2/21-3/26/16 18" RW PIPE REHAB	PV	145458	001 00701	2,836.48	00272231-B
				Payment Amount				2,836.48	
72784	04/26/16	19385	HERMAN WEISSKER INC.	RFND BAL - CLOSED A/C	PV	145389	001 00101	1,152.25	9998642
				Payment Amount				1,152.25	
72785	04/26/16	4144	INTERSTATE BATTERY SYSTEMS	VEH#877 BATTERY	PV	145371	001 00701	123.41	51040796
				Payment Amount				123.41	
72786	04/26/16	16441	IRVINE RANCH WATER	CO-FUNDING WTR BDG	PV	145265	001 00701	3,000.00	25978

Las Virgenes Municipal Water
 A/P Auto Payment Register

Batch Number - 244156
 Bank Account - 00146807 Cash-General

Payment Number	Payment Date	Address Number	Name	Payment Stub Message	Ty	Document Number	Key Item	Co	Amount	Invoice Number
DISTRICT										
72787	04/26/16	3406	JACK JONES TRUCKING, INC.	Payment Amount FREIGHT TO JWC ENVIRO	PV	145465	001	00751	108.65	U02947
72788	04/26/16	20341	AZAR JAVID	Payment Amount RFND BAL - CLOSED A/C	PV	145396	001	00101	211.85	072713
72789	04/26/16	18535	KEMIRA WATER SOLUTIONS, INC.	Payment Amount 10.37 TN FERRIC CHLORIDE	PV	145373	001	00701	4,803.90	9017495647
Alt Payee 18536 KEMIRA WATER SOLUTIONS MAIL CODE 5581, P. O. BOX 105046 ATLANTA GA 30348-5046										
72790	04/26/16	5230	KENNEDY/JENKS CONSULTANTS	Payment Amount P/E 3/25/16 2015 UWMP	PV	145366	001	00701	19,174.73	100387
72791	04/26/16	20342	OHANNES KURKCUOGLU	Payment Amount RFND BAL - CLOSED A/C	PV	145397	001	00101	28.89	072564
72792	04/26/16	3552	LAS VIRGENES MUNICIPAL WATER DISTRICT	Payment Amount RWPS 2/24-3/29/16	PV	145421	001	00701	65.08	2645040616
BLDG#8 RW 2/24-3/29/16 BLDG#8 RW 2/24-3/29/16 BLDG#7 RW 2/24-3/29/16 INDIAN HILLS TNK 2/25-3/30/16 MORRISON P/S 2/25-3/30/16 SDDL TREE TNK IMPRV 3/18-3/1/16										

Batch Number - 244156
 Bank Account - 00146807 Cash-General

Payment Number	Payment Date	Address Number	Name	Payment Stub Message	Ty	Document Number	Key	Amount	Invoice Number
Number	Date	Number				Number	Item Co		Number
72793	04/26/16	19529	LOS ANGELES ENGINEERING, INC.	Payment Amount RFND BAL - CLOSED A/C	PV	145391	001 00101	285.46	9998517A
72794	04/26/16	17295	MAILFINANCE	Payment Amount 4/9--5/8/16 PSTG MCHN RNTL	PV	145355	001 00701	221.98	N5878938
72795	04/26/16	20349	WILLIAM MARGOLIN	Payment Amount TURF RMVL REBATE	PV	145463	001 00101	6,000.00	741115
72796	04/26/16	20336	LAURENCE MILLER	Payment Amount TURF RMVL REBATE	PV	145334	001 00101	6,000.00	3020975
72797	04/26/16	18940	MP PRINTING & MAILING	Payment Amount DO NOT WTR NOTC PRNTG	PV	145301	001 00701	1,650.90	60769
72798	04/26/16	2365	MSO TECHNOLOGIES	Payment Amount JAN'16 GENERATR PLC	PV	145497	001 00701	980.00	5186
72799	04/26/16	2842	NAPA AUTO PARTS	Payment Amount OIL&FILTERS	PV	145474	001 00701	53.50	808936
72800	04/26/16	2846	NATIONAL PLANT SERVICES INC	Payment Amount OIL&FILTERS SHOP SUPPLIES CLN WET WELLS@3/17/16	PV	145474 145475	002 00701 001 00701	8.71 206.18	808936 807219
72801	04/26/16	16754	NATURAL SURROUNDINGS	Payment Amount APR'16 FLORAL MAINT	PV	145473	001 00701	235.00	6502
72802	04/26/16	20350	DEREK NEWMAN	Payment Amount EQP RENTL-VIDEO 4/10/16	PV	145477	001 00101	223.65	481814
72803	04/26/16	19299	NORTH AMERICAN SAFETY, INC.	Payment Amount RAIN JACKETS&PANTS SET UP FEE	PV	145502 145503	001 00701 001 00701	7,318.05 20.00	17669 17669

Batch Number - 244156
 Bank Account - 00146807 Cash-General

Payment Number	Payment Date	Address Number	Name	Payment Stub Message	Document Ty	Document Number	Key Itm	Key Co	Amount	Invoice Number
72804	04/26/16	16372	OLIN CORPORATION - CHLORALKALI	Payment Amount 4,960 GAL HYPOCHLORITE	PV	145499	001	00701	2,704.26	2150180
				4,938 GAL HYPOCHLORITE	PV	145500	001	00701	2,716.36	2150492
			Alt Payee 16373 OLIN CORPORATION - CHLORALKALI P.O. BOX 402766 ATLANTA GA 30384-2766	Payment Amount MAR'16 CNTRT	PV	145260	001	00701	1,301.79	97873
72805	04/26/16	18946	PACIFIC ADVANCED CIVIL ENGINEERING, INC.	TNK DSN					5,420.62	
				MAR'16 SLUDGE WET WELL	PV	145261	001	00701	5,000.00	97872
72806	04/26/16	18874	PACIFIC HYDROTECH CORPORATION	Payment Amount PMT#1-WLK P/S UPGRD	PV	145409	001	00701	6,301.79	10558/#1
				5% RETENTION-P/E	PD	145410	001	00301	2,617.50	10558/RTN#1
				3/31/16					49,732.50	
72807	04/26/16	20343	PENGUIN BROTHERS INC.	Payment Amount RFND BAL - CLOSED A/C	PV	145398	001	00101	1,204.54	9996222
72808	04/26/16	18064	PHOENIX CIVIL ENGINEERING, INC.	Payment Amount P/E 3/31/16 TWN LKS DRNG	PV	145289	001	00701	803.25	PHOE16-089
72809	04/26/16	12954	POLYDYNE INC.	Payment Amount 45,620 LB CLARIFLOC	PV	145501	001	00701	803.25	1039867
				Payment Amount PRGRMBL LED INDICATRS	PV	145340	001	00701	41,023.79	26477
				FREIGHT	PV	145340	002	00701	19.57	26477
				Payment Amount					2,668.37	

Las Virgenes Municipal Water
 A/P Auto Payment Register

Batch Number - 244156
 Bank Account - 00146807 Cash-General

Payment Number	Payment Date	Address Number	Name	Payment Stub Message	Document Ty	Document Number	Key Item	Key Co	Amount	Invoice Number
72811	04/26/16	17326	RINCON CONSULTANTS, INC.	P/E 2/28/16 TREE MONTRNG SRV	PV	145498	001	00701	2,825.50	25509
				Payment Amount					2,825.50	
72812	04/26/16	16859	RMC WATER AND ENVIRONMENT	2/27-3/25/16 WDLND HLLS RW	PV	145359	001	00701	16,020.20	21680
				Payment Amount					16,020.20	
72813	04/26/16	17174	ROTH STAFFING COMPANIES, LP	11/16-11/20/1 5 E.M.AGUILAR	PV	142964	001	00701	789.21	13208687
				3/21-3/25/16 E.M.AGUILAR	PV	145287	001	00701	620.00	13252255
				3/21-3/25/16 E.M.AGUILAR	PV	145288	001	00701	179.20	13262255
				3/28-4/1/16 E.M.AGUILAR	PV	145493	001	00701	799.20	13263286
				4/4-4/8/16 E.M.AGUILAR	PV	145494	001	00701	764.24	13266238
				Payment Amount					3,151.85	
72814	04/26/16	20344	GEOFFREY ROUSS	RFND BAL - CLOSED A/C	PV	145399	001	00101	6.43	059249
				Payment Amount					6.43	
72815	04/26/16	8693	ROYSTON GROUP	CONVYNC EQUIP RPR PARTS	PV	145383	001	00701	925.14	2177-1350
				FREIGHT	PV	145383	007	00701	46.20	2177-1350
				Payment Amount					971.34	
72816	04/26/16	20332	KENNETH SAMPSON	TURF RMVL REBATE	PV	145266	001	00101	2,564.00	1500064
				Payment Amount					2,564.00	
72817	04/26/16	6766	SAWYER PETROLEUM	797.2 GAL RED DYE DIESEL	PV	145472	001	00701	1,536.42	V102132
				Payment Amount					1,536.42	
72818	04/26/16	6940	SECTRAN SECURITY, INC.	APR'16 COURIER SVC	PV	145354	001	00701	294.98	16040634
				Payment Amount					294.98	
72819	04/26/16	20345	SHAMROCK ACQUISITIONS LLC	RFND BAL - CLOSED A/C	PV	145400	001	00101	22.03	071148
				Payment Amount					22.03	
72820	04/26/16	20346	LORETTA SHUKEN	RFND BAL - CLOSED A/C	PV	145401	001	00101	50.55	067946
				Payment Amount					50.55	

Batch Number - 244156
 Bank Account - 00146807 Cash-General

Payment Number	Payment Date	Address Number	Name	Payment Stub Message	Document Ty	Document Number	Key Item	Key Co	Amount	Invoice Number
72821	04/26/16	2964	STATE BOARD OF EQUALIZATION	Payment Amount SALES/USE TAX-1ST QT'16	PV	145491	001	00701	6,047.00	97817885/0331
									50.55	16
72822	04/26/16	16416	KAREN SWERLING	Payment Amount RFND BAL - CLOSED A/C	PV	145388	001	00101	8.18	048034
72823	04/26/16	3789	T & T TRUCK & CRANE SERVICE	Payment Amount STINGER@TAPIA 3/23/16	PV	145357	001	00701	870.00	0125131-IN
				Payment Amount 40-TN HYD CRANE@RLV 3/29/16	PV	145358	001	00701	1,072.50	0125183-IN
72824	04/26/16	16164	TECHNIQUE DATA SYSTEMS	Payment Amount CANON CR-1901	PV	145262	001	00701	2,667.88	044962
				Payment Amount CHK SCNR FREIGHT	PV	145262	002	00701	35.63	044962
72825	04/26/16	3006	UNDERGROUND SERVICEALERT	Payment Amount 199 NEW TICKET CHGS	PV	145349	001	00701	298.50	320160415
				Payment Amount CABLE	PV	145342	001	00751	227.25	LVMWD-2
72826	04/26/16	8455	VARNA ELECTRONICS	RPLCMT@TAPIA& WLK	PV	145342	002	00751	227.25	LVMWD-2
				Payment Amount VEH#896	PV	145459	001	00701	123.62	021437
72827	04/26/16	2436	VINCE BARNES AUTOMOTIVE	OIL/FILTRS VEH#816 FUEL PMP&SERP BELT VEH#847 STRT MTR&FLTRS	PV	145460	001	00701	653.38	021430
				Payment Amount VISIONLINE 4/15/16--4/14/17	PV	145461	001	00701	522.18	021444
				Payment Amount 3/20--3/26/16	PV	145464	001	00701	6,945.75	32371
72829	04/26/16	19685	W. LITTEN INC.	Payment Amount SRV@RLV	PV	145282	001	00701	5,039.25	11069

Las Virgenes Municipal Water
 A/P Auto Payment Register

Batch Number - 244156
 Bank Account - 00146807 Cash-General

Payment Number	Payment Date	Address Number	Name	Payment Stub Message	Document Ty	Document Number	Key Item	Key Co	Amount	Invoice Number
				3/27-4/2/16	PV	145283	001	00701	5,184.70	11071
				SRV@RLV						
				CLEAR	PV	145403	001	00751	254.40	11073
				TRAILS@CRK						
				4/5/16						
				RPR RW	PV	145404	001	00751	696.53	11074
				LN&DRAIN LNS						
				P/E 4/8/16						
				SRV	PV	145411	001	00701	5,005.15	11072
				4/3-4/9/16@RL						
				V						
				Payment Amount					16,180.03	
72830	04/26/16	3037	WAITE BROS. PLUMBING	FLUSHOMTR	PV	145356	001	00701	585.00	38975
				SRV@RLV						
				PLUMBING	PV	145504	001	00701	245.00	38954
				SRV@BLDG#8						
				Payment Amount					830.00	
72831	04/26/16	3044	WATERUSE ASSOCIATION	2016	PV	145338	001	00701	1,947.40	D20161261
				MEMBERSHIP						
				DUES						
				Payment Amount					1,947.40	
72832	04/26/16	18914	WECK LABORATORIES, INC.	LAB SRV@TAPIA	PV	145351	001	00701	210.00	W6D0129-LV
				EFFLNT GRAB						
				LAB SRV@TAPIA	PV	145352	001	00701	488.00	W6D0102-LV
				EFFLNT						
				COMPOSITE						
				LAB	PV	145353	001	00701	3,927.00	W6D0130-LV
				SRV@MALIBU						
				CREEK						
				Payment Amount					4,625.00	
72833	04/26/16	20348	DIANE M. WEISS	TURF RMVL	PV	145427	001	00101	4,270.00	1020274
				REBATE						
				Payment Amount					4,270.00	
72834	04/26/16	3048	WEST COAST AIR CONDITIONING	A/C PM@BLDG#7	PV	145467	001	00701	265.00	S73564
				A/C PM@LV-2	PV	145468	001	00701	115.00	S73609
				A/C PM@BLDG#2	PV	145469	001	00701	30.00	S73568
				A/C PM@WLK	PV	145470	001	00701	45.00	S73626
				A/C PM@LS#2	PV	145471	001	00701	62.00	S73621

Batch Number - 244156

Bank Account - 00146807 Cash-General

Las Virgenes Municipal Water
A/P Auto Payment Register

Payment Number	Date	Address Number	Name	Payment Stub Message	Ty	Document Number	Key		Amount	Invoice Number
							Item	Co		
				HOT WTR BOILR	PV	145496	001	00701	2,330.68	S73253
				PMP						
				Payment Amount				2,847.68		
72835	04/26/16	18540	WEST COAST POWER SOLUTIONS	SRV@BLDG#7 3/14/16	PV	145360	001	00701	675.00	S5371
				Payment Amount				675.00		
72836	04/26/16	20347	WH AGOURA 24 LP	RFND BAL - CLOSED A/C	PV	145402	001	00101	29.90	069687
				Payment Amount				29.90		
				Total Amount of Payments Written				480,845.66		
				Total Number of Payments Written				96		



LAS VIRGENES MUNICIPAL WATER DISTRICT
4232 Las Virgenes Road, Calabasas CA 91302

MINUTES
REGULAR MEETING

5:00 PM

April 12, 2016

PLEDGE OF ALLEGIANCE

The Pledge of Allegiance to the Flag was led by David Lippman.

1. CALL TO ORDER AND ROLL CALL

The meeting was called to order at **5:00 p.m.** by Board President Peterson in the Board Room at Las Virgenes Municipal Water District headquarters at 4232 Las Virgenes Road, Calabasas CA 91302. Josie Guzman, Clerk of the Board, conducted the roll call.

Present: Directors Charles Caspary, Jay Lewitt, Leonard Polan, Lee Renger, and Glen Peterson

Absent: None

Staff Present: David Pedersen, General Manager
David Lippman, Director of Facilities and Operations
Donald Patterson, Director of Finance and Administration
Carlos Reyes, Director of Resource Conservation and Public Outreach
Josie Guzman, Clerk of the Board
Steven O'Neill, District Counsel

2. APPROVAL OF AGENDA

Board President Peterson asked to change the order of the agenda by moving up Item 7A to follow adoption of the Consent Calendar.

Director Renger moved to approve the agenda as amended. Motion seconded by Director Caspary. Motion carried unanimously.

3. PUBLIC COMMENTS

None.

4. CONSENT CALENDAR

A List of Demands: April 12, 2016 - Approve

B Minutes: Regular Meeting of March 22, 2016 - Approve

C Directors' Per Diem – March 2016 - Ratify

D Pressure Regulator Request for Bids and Meter Parts and Fittings Contract Increase

Approve a Request for Bids for pressure regulators and authorize the General Manager to increase annual contract amount, and subsequent renewal option, with Famcon Pipe and Supply, Inc. for the purchase of Ford meter parts and fittings to \$75,000.

E 18-inch Recycled Water Pipeline Joint Bonding Repair Project: Call for Bids

Authorize a Call for Bids for the 18-inch Recycled Water Pipeline Joint Bonding Repair Project.

F Annual Report: Records Review and Destruction

Authorize the destruction of records except for those noted.

Director Caspary moved to approve the Consent Calendar as presented. Motion seconded by Director Renger. Motion carried unanimously.

7. BOARD OF DIRECTORS

A Water Budget “Rollover” Proposal: Review and Discuss

Review and discuss the water budget “rollover” proposal by Mr. Joel Friedman.

Joel Friedman stated that he previously presented a proposal to the Board to allow District customers to “rollover” unused water budget amounts month-to-month. He referred to charts he prepared with a hypothetical example of the current water budget compared to a proposed rollover plan.

Board President Peterson stated that the purpose of water budgets was to encourage water conservation and to help comply with the State’s mandate to reduce water usage 20 percent by 2020.

There was a lengthy discussion between Mr. Friedman and the Board regarding the proposal.

General Manager David Pedersen stated that the main concern when exceeding the water budget was recovery of the incrementally higher unit cost of water associated with peaking. He explained the budget-based rate structure was designed to recover the cost of providing water service to customers and encourage water conservation at all times.

No action was taken.

5. ILLUSTRATIVE AND/OR VERBAL PRESENTATION AGENDA ITEMS

A Owl House Presentation by Camp David Gonzales Students

Water Systems/Facilities Manager Larry Miller stated that the Board previously directed staff to work with Camp David Gonzales to construct owl houses for installation at District facilities for natural rodent control. He noted that the District purchased the wood, and the students from Camp David Gonzales built owl houses.

Ty Kastendiek, instructor at Camp David Gonzales, reported that the students assisted in building eight owl houses for the District. He stated that the theme of the project was social responsibility, and the students conducted an analysis to determine the best use of materials. He displayed a sample of an owl house constructed with plywood and painted with exterior paint, and he explained that the owl houses would be suspended from trees with wire. He noted that an owl house would provide shelter for two adult owls and approximately five to six offspring. He also noted that one owl consumes approximately 180 rodents per month.

B Legislative and Regulatory Updates

General Manager David Pedersen stated that the State Water Resources Control Board (Water Board) is considering making amendments to the emergency regulations in either May or June, and a workshop is scheduled on April 20 to receive public input. He noted that the District would be signing a coalition letter with other agencies with similar concerns and interests asking the Water Board to consider a demand and supply-based balance for water use restrictions for the current year and the two upcoming years. He stated that agencies would either demonstrate they have sufficient water for supply and demand or implement measures to reduce their demand to bring them into balance. He also stated that the Water Board would also consider long-term water use efficiency standards. He noted that there are concerns that the current emergency regulations do not reflect local issues and nuances affecting water use that need to be considered in a long-term policy. He also noted that the Association of California Water Agencies, American Water Works Association, California Municipal Water Utilities, and California Urban Water Agencies would provide a proposal for a long-term framework for water use efficiency.

Public Affairs and Communications Manager Jeff Reinhardt reported that the District sent a letter of support for HR 4615 (Huffman), The Water Conservation Tax Parity Act. He noted that Congressman John Garamendi planned on introducing a twin bill to Senator Dianne Feinstein's bill on drought relief and long-term and short-term planning, and the Congressman is seeking letters of support. He also noted that the Assembly Water, Parks, and Wildlife Committee unanimously cleared AB 2488, which would allow MWD to reconstruct the Foothill Feeder without violating the Endangered Species Act. He reported that AB 1713 (Eggman) for the tunnels project was postponed one week, as well as the proposal by Assemblymember Jim Frazier to add the California WaterFix to the Delta Reform Act of 2009, because of inconsistencies with the co-equal goals. He noted that AB 2515 (Weber), The Water Conservation in Landscaping Act proposes to synchronize the schedule on model landscape ordinances with Building Code updates. He reported that Los Angeles County Supervisors Sheila Kuehl and Hilda Solis co-sponsored a motion to design a County Drought Resiliency Work Plan to increase local water self-reliance, drought preparedness, and improve water quality, and help communities adapt to the effects of climate change. He noted that Supervisor Kuehl made a separate motion with Supervisor Mark Ridley-Thomas to develop a net zero water use policy to help ensure that future developments will not increase regional demand for increasingly limited water. He also noted that a range of stakeholders would participate in designing the Net Zero Water Ordinance. He stated there was no update regarding Senator Fran Pavley's bill regarding water-energy nexus or Senator Hertzberg's bill regarding wastewater discharges, which is opposed by the California Association of Sanitation Agencies.

General Manager David Pedersen stated that staff would monitor the County Drought Resiliency Work Plan because it appeared to be similar to the Clean Water Clean Beaches Initiative, which focused on water quality improvements and MS4 compliance. He also stated that staff would monitor the Net Zero Water Ordinance. Director Lewitt suggested that District staff seek participation on the County's committee for preparing the Net Zero Water Ordinance. General Manager David Pedersen responded that staff would send a letter and offer to participate on this committee.

C Water Supply Conditions and Drought Response

General Manager David Pedersen reported that the District achieved a 30 percent reduction in water usage for the month of March as compared to 2013 and a cumulative total reduction of 28.5 percent. He noted that the State Board recently awarded the District a 35 percent reduction standard.

6. TREASURER

Director Lewitt stated that the Treasurer's report was in order. He inquired regarding a payment made to In N Out Burger. Director of Finance and Administration Donald Patterson responded that this was a refund of their connection deposit for their new restaurant in Westlake Village.

7. BOARD OF DIRECTORS

B Support for ACA 8 (Bloom): Local Government Financing

Express support for ACA 8 (Bloom): Local Government Financing: water facilities and infrastructure: voter approval.

General Manager David Pedersen presented the report.

Director Lewitt moved to approve Item 7B as presented. Motion seconded by Director Polan.

Director Caspary expressed his concern that the proposed amendment would sidestep Proposition 13 and make it easier for public agencies to incur debt when there may be alternative funding options.

Director Renger stated he would be supportive if a sunset clause was included.

Motion carried by the following roll call vote:

AYES: Lewitt, Polan, Peterson

NOES: Caspary, Renger

ABSTAIN: None

C Long-Term Water Conservation and Management Policy: Resolution

Pass, approve and adopt Resolution No. 2491 regarding long-term water conservation and management policy in California.

RESOLUTION NO. 2491

A RESOLUTION OF THE BOARD OF DIRECTORS OF LAS VIRGENES MUNICIPAL WATER DISTRICT REGARDING LONG-TERM WATER CONSERVATION AND MANAGEMENT POLICY IN CALIFORNIA

(Reference is hereby made to Resolution No. 2491 on file in the District's Resolution Book and by this reference the same is incorporated herein.)

General Manager David Pedersen presented the report.

Director Renger moved to approve Item 7C as presented. Motion seconded by Director Caspary. Motion carried unanimously.

8. FINANCE AND ADMINISTRATION

A Clean Water State Revolving Fund Application for AMR/AMI Project: Resolutions

Pass, approve and adopt the proposed resolutions required for a Clean Water State Revolving Fund application.

RESOLUTION NO. 2486

A RESOLUTION OF THE BOARD OF DIRECTORS OF LAS VIRGENES MUNICIPAL WATER DISTRICT AUTHORIZING APPLICATION FOR FUNDING FROM THE CLEAN WATER STATE REVOLVING LOAN FUND

RESOLUTION NO. 2487

A RESOLUTION OF THE BOARD OF DIRECTORS OF LAS VIRGENES MUNICIPAL WATER DISTRICT PLEDGED REVENUES AND FUND(s) RESOLUTION

RESOLUTION NO. 2488

A RESOLUTION OF THE BOARD OF DIRECTORS OF LAS VIRGENES MUNICIPAL WATER DISTRICT PLEDGING MATCH FINANCING

RESOLUTION NO. 2489

A RESOLUTION OF THE BOARD OF DIRECTORS OF LAS VIRGENES MUNICIPAL WATER DISTRICT AUTHORIZING REIMBURSEMENT TO THE CLEAN WATER STATE REVOLVING LOAN FUND

(Reference is hereby made to Resolution Nos. 2486, 2487, 2488, and 2489 on file in the District's Resolution Book and by this reference the same is incorporated herein.)

Director of Finance and Administration Donald Patterson presented the report.

Director Caspary moved to approve Item 8A as presented. Motion seconded by Director Polan.

Director of Resource Conservation and Public Outreach Carlos Reyes responded to a question regarding the life expectancy of water meters by stating that the average life expectancy is 20 years.

Motion carried unanimously.

B Cellular Device Reimbursement Policy

Approve the proposed Cellular Device Reimbursement Policy.

General Manager David Pedersen presented the report.

Director Lewitt moved to approve Item 8B as presented. Motion seconded by Director Caspary.

A discussion ensued regarding potential conflicts with employee confidentiality and the District's ability to access the phone's data. General Manager David Pedersen noted that employees would be required to sign the Cellular Device Enrollment Form, which includes agreeing that personal cellular devices or data therein would be subject public records requests and subpoenas. Director Lewitt suggested that the employees be made aware that text messages may be included if they pertain to District business.

Motion carried unanimously.

9. LEGAL SERVICES

A Update to Purchasing Policy: Resolution

Pass, approve and adopt Resolution No. 2490, modifying Las Virgenes Municipal Water District Code.

RESOLUTION NO. 2490

A RESOLUTION OF THE BOARD OF DIRECTORS OF LAS VIRGENES MUNICIPAL WATER DISTRICT ADOPTING LAS VIRGENES MUNICIPAL WATER DISTRICT CODE TITLE 2, CHAPTER 6, ARTICLE 4 – PURCHASING AND REPEALING CONFLICTING SECTIONS OF RESOLUTION NO. 2468

General Manager David Pedersen presented the report.

Director Caspary moved to approve Item 9A as presented. Motion seconded by Director Lewitt.

Director Caspary requested that the General Manager continue to report to the Board on emergency purchases.

Motion carried unanimously.

10. INFORMATION ITEMS

A Sanitation Rate for Single-Family Residential Customers

B Corrosion Control Desktop Study

Director Caspary commented that the study was very reassuring.

11. NON-ACTION ITEMS

A Organization Reports

(1) MWD Representative Report/Agenda(s)

Board President Peterson reported that the MWD Board adopted its two-year budget, which includes a four percent increase in wholesale water rates. He noted that a large group of people spoke on several issues during the MWD Board meeting. He also noted that the MWD Board approved negotiating land leases in the Palo Verde Valley. He commented that the Colorado River Aqueduct Inspection Trip held the past weekend was one of the best ever.

(2) Other

B Director's Reports on Outside Meetings

None.

C General Manager Reports

(1) General Business

General Manager David Pedersen reported that the MWD completed its shutdown for repairs to the Sepulveda Feeder and normal operations had been restored. He acknowledged District staff for their efforts and customers for reducing their water use during the shutdown. He noted the following meetings and events: Las Virgenes – Triunfo Joint Powers Authority special meeting on April 14; Las Virgenes Municipal Water District special meeting on April 18 for a workshop regarding the strategic plan update and preliminary budget presentation; California Water Policy Conference - POWER at UC Davis April 20 through 21; and the Association of Water Agencies of Ventura County Water Symposium on April 21.

(2) Follow-Up Items

General Manager David Pedersen mentioned that an item regarding temporary water meters would be included on the next agenda.

D Directors' Comments

Director Polan inquired regarding the status of the installation of a native garden in front of District headquarters. Director of Resource Conservation and Public Outreach Carlos Reyes responded that native plants were planted prior to the street construction; however, some plants were removed. He stated that the plants would be replanted after construction is completed.

12. FUTURE AGENDA ITEMS

None.

13. PUBLIC COMMENTS

None.

14. CLOSED SESSION

The Board recessed to Closed Session at **6:43 p.m.** to discuss the following item:

A Conference with District Counsel – Existing Litigation (Government Code Section 54956.9(a)):

1. Las Virgenes – Triunfo Joint Powers Authority v. United States Environmental Protection Agency and Heal the Bay, Inc. v. Lisa P. Jackson (TMDL cases)
2. Las Virgenes – Triunfo Joint Powers Authority v. United States Environmental Protection Agency (FOIA case)
3. San Diego County Water Authority v. Metropolitan Water District of Southern California, et al.

15. OPEN SESSION AND ADJOURNMENT

The Board reconvened to Open Session at **7:25 p.m.**

District Counsel Steven O'Neill reported that during the Closed Session a report was given regarding San Diego County Water Authority v. Metropolitan Water District of Southern California, et al., and the Board provided direction to staff. No other formal action was taken.

Seeing no further business to come before the Board, the meeting was duly adjourned at **7:25 p.m.**

GLEN PETERSON, President
Board of Directors
Las Virgenes Municipal Water District

ATTEST:

CHARLES CASPARY, Secretary
Board of Directors
Las Virgenes Municipal Water District

(SEAL)



April 26, 2016 LVMWD Regular Board Meeting

TO: Board of Directors

FROM: Finance & Administration

Subject : Cash and Investment Report for March 2016

SUMMARY:

During March, staff continued to keep maturities short with an average of 2.20 years. Three investments were called or matured and one investment was purchased. The District's total portfolio was valued at \$64,117,425 on March 31, 2016, up 2.99% from February 29, 2016.

RECOMMENDATION(S):

Receive and file the Cash and Investment Report for March 2016.

FISCAL IMPACT:

No

ITEM BUDGETED:

No

DISCUSSION:

As of March 2016, the District held \$64,117,425 in its portfolio, down 0.23% year-over-year, primary due to withdraws to fund capital improvement projects. The portfolio was also up from the previous month's total of \$62,256,672. The majority of the funds were held in the District's investment accounts, which had a March 31, 2016 value of \$30,695,111. LAIF held the majority of the remaining funds, in the amount of \$28,633,594. A small portion of the funds, \$2,011,890, were held in the pooled investment fund of CalTrust. A significant portion of remaining funds were held in a trustee account as required reserves for the Bond Refunding: \$2,761,030. The annualized yield for the District's Investment Portfolio was up on a year-over-year basis to 1.18% in March 2016, as compared to the prior month's return of 1.16%. The total yield on the District's accounts was 0.84%, up year-over-year from 0.72%.

The following investments were called in March:

- FHLB – 1.33%, invested on 3/18/15 in the amount of \$1 million.
- FHLB – 1.80%, invested on 12/30/15 in the amount of \$1 million.

The following investment matured in March:

- FFCB – 1.05%, invested on 3/28/12 in the amount of \$1 million.

The following investment was purchased in March:

- Newark Unified School District – 1.779%, invested on 3/17/16 in the amount of \$910,000, AA-.

The following transactions occurred in the District's LAIF account:

- 03/17/16 Withdrawal (\$900,000)
- 03/18/16 Deposit 1,000,000
- 03/23/16 Deposit 1,000,000
- 03/30/16 Deposit 2,000,000
- 03/30/16 Deposit 800,000

The District's investments are in compliance with the adopted Investment Policy, and sufficient funds are available from current rate revenue and funds held in LAIF to meet projected expenditures during the next six months.

Cash Analysis:

Another important aspect of the Monthly Cash and Investment Report is to monitor the District's performance compared to its adopted Financial Policies. Attachment B shows the District's total cash and investments as of March 31, 2016 and compares the balances to the adopted Financial Policies.

As of March 31, 2016, the Potable Water Enterprise was \$10.5 million below the levels set forth in the District's Financial Policies. This was primarily due to a spend down of reserves for the Backbone Improvement Program and use of \$2.7 million from the Rate Stabilization Fund in Fiscal Year 2015-16 to mitigate the effects of the drought on rates. The five-year rate plan was developed to re-build the reserves over the five-year period.

The Sanitation Enterprise had cash and investments that exceeded the District's Financial Policies by \$12.5 million, and the Recycled Water Enterprise had cash and investments that exceeded the District's Financial Policy levels by \$13.1 million. These Enterprises are expected to incur significant expenses during the next five-year period in response to the need to comply with new National Pollution Discharge Elimination System (NPDES) permit requirements and for the construction of a project to address seasonal storage needs in the Recycled Water Enterprise. These planned expenditures were also considered as part of the five-year rate plan that began in January 2016, and staff is exploring additional funding options for these projects.

GOALS:

Ensure Effective Utilization of the Public's Assets and Money

Prepared by: Donald Patterson, Director of Finance and Administration

ATTACHMENTS:

March Charts
March Investment Report
Attachment A
March 2016 Cash Report

The District's total yield varies depending on the percentage of the portfolio in LAIF and CalTRUST versus the Investment Portfolio. If a higher percentage of the District's funds are in LAIF and CalTRUST, the lower the total yield since LAIF and CalTRUST are more liquid, more conservative, and have significantly lower yields than bonds held in the Investment Portfolio. As of March 2016, LAIF held 44.66% of the District's portfolio and the investment portfolio held 47.87%, the remainder was held in CalTRUST and Wells Fargo. As can be seen in the chart below, the total yield in March 2016 was 0.84%, 0.01% lower than February 2016 and up from 0.72% one year ago.

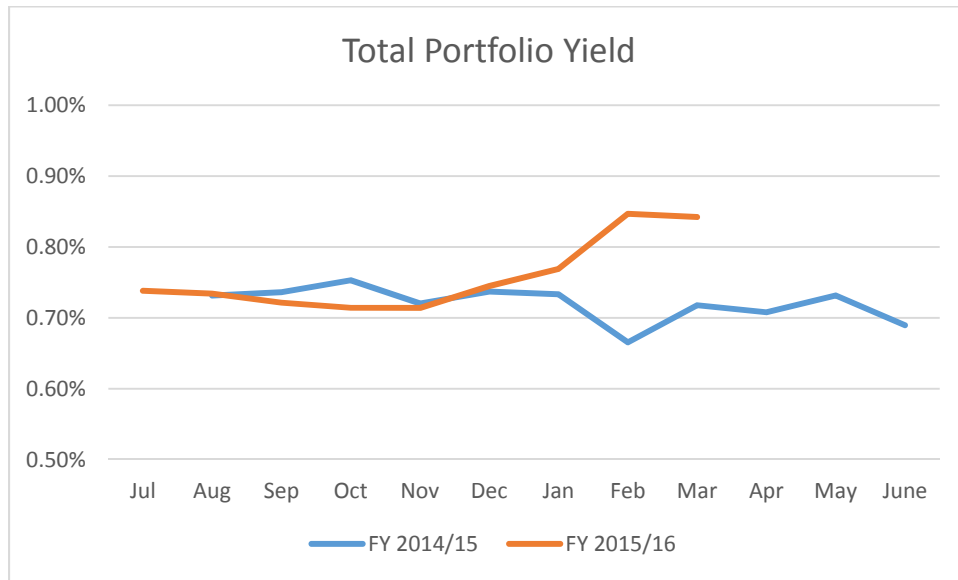

In March, the annualized yield for the District's Investment Portfolio was 1.18%, up from February's 1.16% and up 21 basis points from a year ago. The chart below shows annualized monthly yield of the current fiscal year compared with the same monthly yield over the previous fiscal year.

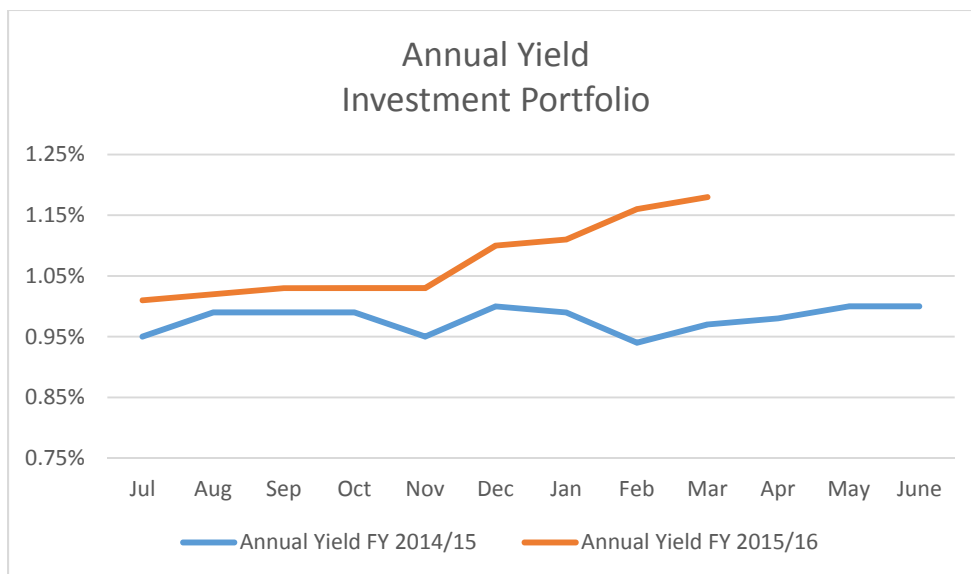

The following chart shows the average annualized LAIF and CalTRUST yields over the past twelve months. In March, the LAIF yield exceeded the CalTRUST yield by 3 basis points. The March LAIF yield was 0.51%, up from 0.28% a year ago and the CalTRUST yield was 0.48%, up from 0.37% from a year ago.

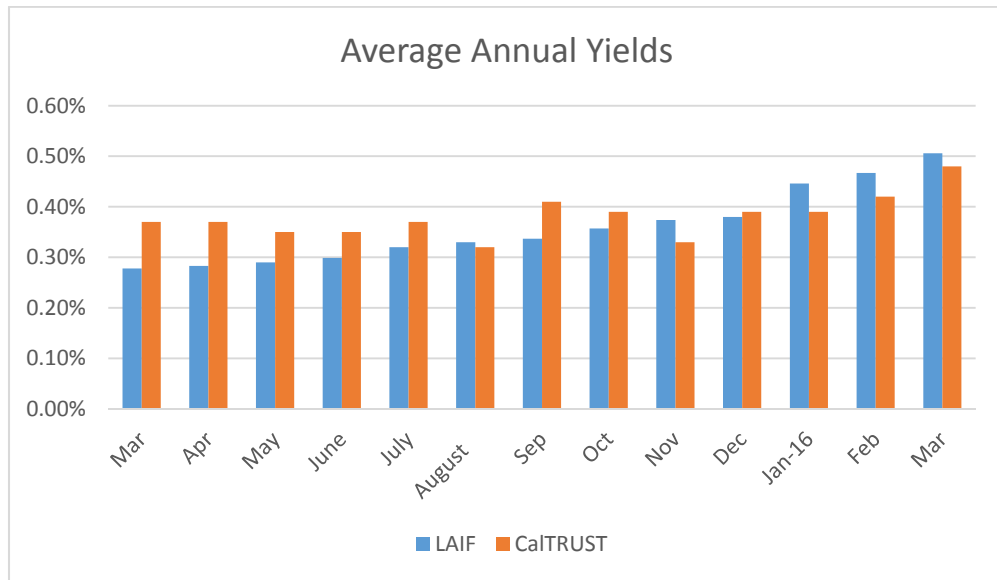

The District varies the time to maturity based on several factors including maintaining sufficient liquidity for anticipated capital expenditures, anticipated direction of future interest rates, and the quality of investments offered for a given maturity. In March, the average time to maturity was 2.20 years with \$8.6 million maturing within the next year and \$10 million maturing between 2 and 3 years, representing 60.6% of the portfolio maturing within those two time frames.

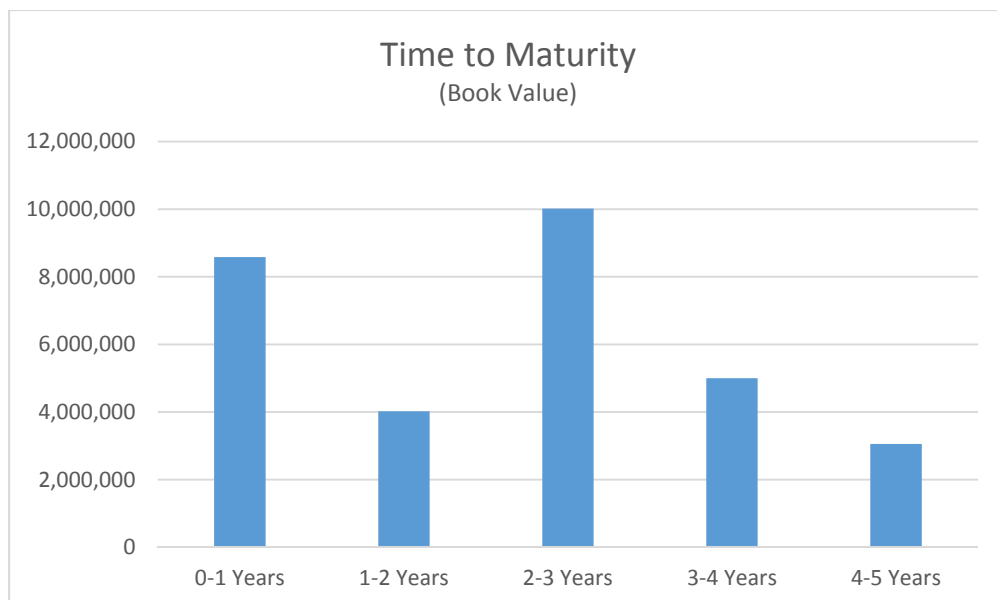

In order to benchmark how the District's portfolio is performing, it is useful to compare its investment portfolio with a comparable index. The District has historically compared its investment portfolio returns to the 2-Year and 3-Year Treasury notes. As shown in the chart below, the District's investment portfolio has generally mirrored the returns of the 3-Year Treasury. In November and December, Treasury Yields increased significantly as the Federal Reserve Bank Rate increased. The downward trend that started in January continued with 3-year Treasury Notes hitting 0.73% on March 31, down from 1.31% at the start of January.

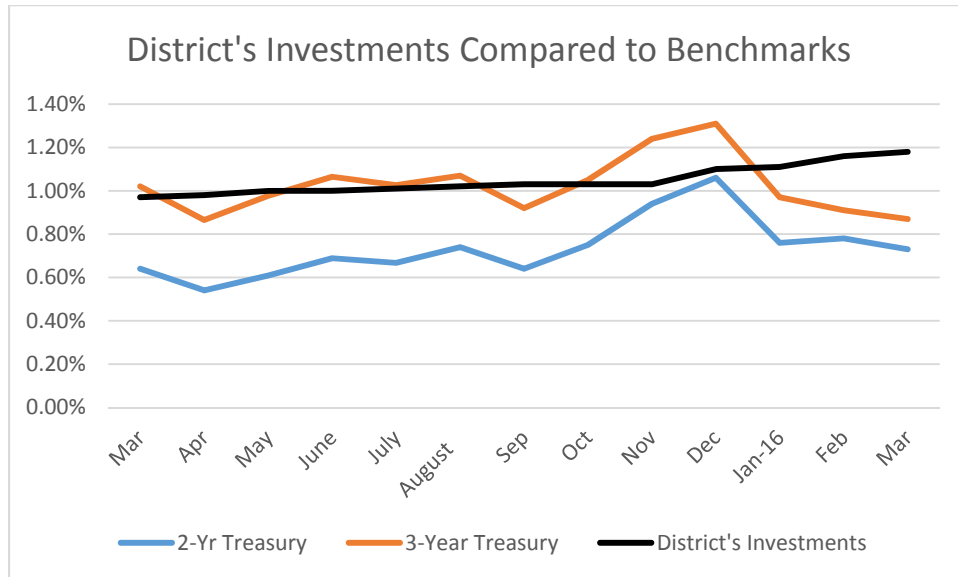

Equally important to monitoring performance is to monitor total portfolio value which includes the District's Investment Portfolio, LAIF and CalTRUST accounts. The chart below shows the Total Portfolio Value between 2009 and 2016. The chart demonstrates the effect of the Board's policy to minimize rate increases over the past 5 years and to utilize PAYGO for large capital projects by drawing down reserves. The significant reduction in 2014 is primarily because of the Torchwood Tank and the backbone improvement projects. In February, the District's portfolio increased 2.99% to \$64,117,425.

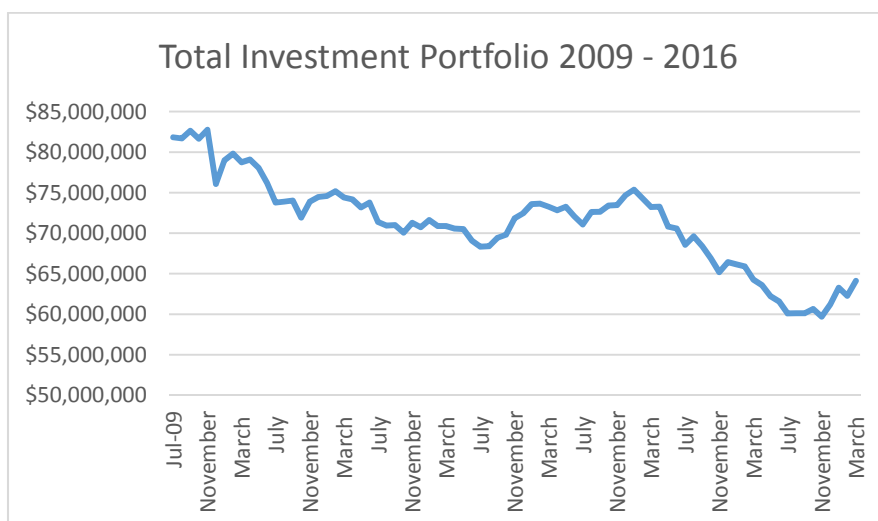

The chart below compares Total Portfolio Value in the current Fiscal Year, compared to the same period in the previous fiscal year.

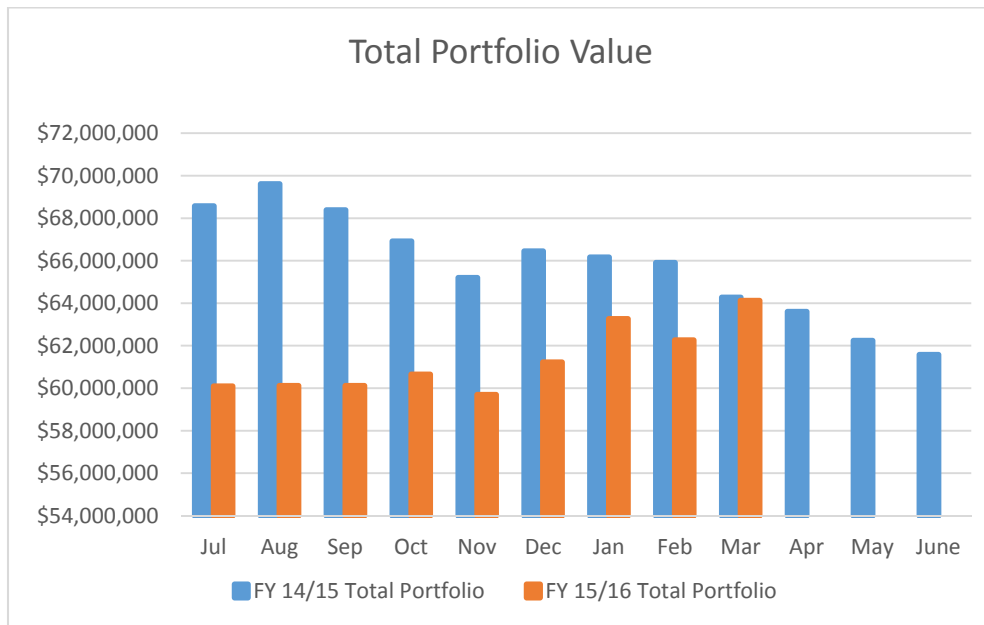

The chart below shows the value of the District’s Investment, LAIF and CalTRUST portfolios over the past twelve month period. The increase in LAIF since November reflects the District’s wait and see approach to how interest rates moved in response to December’s Federal Funds increase. In February, the District increased its investment portfolio due to positive interest rates offered during target maturity periods. In March, the value of LAIF increased as bonds were called and reinvested in issuances that settled in April.

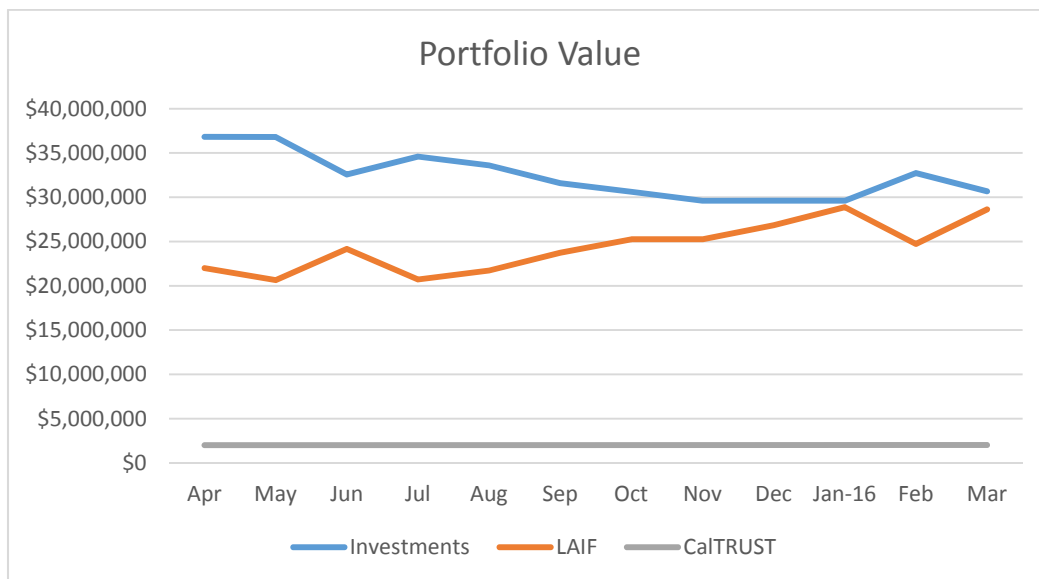

Date: April 12, 2016
 To: David W. Pedersen, General Manager
 From: Finance and Administration Department
 Subject: Investment Report for the Month of March 2016

Summary of Investments

Investments Maturing Within Six Months:

Disc./Cpn Rate	Yield To Maturity	Yield To Call	Investment Type	Date Invested	Next Call Date	Date Matures	Book Value	Par Value	Market Value	Market Value Source
							Sub-Total			
							0	0	0	

Investments Maturing After Six Months:

0.625%	0.700%		FHLMC-Bullet	10/26/12		11/01/16	997,040	1,000,000	1,000,340	Custodian
0.690%	0.690%		PST-Muni Bond	03/26/13		11/01/16	1,000,000	1,000,000	1,000,000	Custodian
0.625%	0.625%		FNMA-Bullet	11/28/12		11/28/16	2,000,000	2,000,000	2,002,080	Custodian
0.600%	0.600%	0.600%	FFCB-Callable Coupon	12/13/12	Continuous	12/12/16	1,000,000	1,000,000	1,000,030	Custodian
0.832%	0.832%		ARLDEV-Muni Bond	06/03/13		12/15/16	1,585,000	1,585,000	1,585,127	Custodian
0.600%	0.600%		FFCB-Bullet	12/27/12		12/27/16	1,000,000	1,000,000	999,620	Custodian
1.270%	1.270%		FHLB-Bullet	03/30/12		03/02/17	1,000,000	1,000,000	1,005,910	Custodian
0.820%	0.860%	0.860%	FFCB-Callable Coupon	10/26/12	Continuous	07/11/17	998,000	1,000,000	1,000,010	Custodian
1.585%	1.100%		LVNSCD-Muni Bond	02/20/13		11/01/17	1,022,130	1,000,000	1,006,760	Custodian
0.750%	0.750%		FHLMC-Bullet	05/28/13		11/28/17	1,000,000	1,000,000	999,200	Custodian
1.000%	1.000%		FHLMC-Bullet	03/26/13		03/26/18	1,000,000	1,000,000	1,001,840	Custodian
1.020%	1.020%	1.043%	FHLMC-Callable Coupon	04/30/13	04/30/16	04/30/18	999,500	1,000,000	1,000,550	Custodian
0.950%	0.950%		FHLMC-Bullet	05/22/13		05/22/18	1,000,000	1,000,000	998,260	Custodian
0.75% & Up ¹	1.117%	0.775%	FNMA-Callable Coupon	05/29/13	05/29/16	05/29/18	1,000,000	1,000,000	1,000,980	Custodian
1.250%	1.250%		FHLB-Bullet	06/26/13		06/26/18	1,000,000	1,000,000	1,006,050	Custodian
1.500%	1.500%	1.500%	FNMA-Callable Coupon	09/19/14	09/19/16	09/19/18	1,000,000	1,000,000	1,003,890	Custodian
1.250%	1.250%	1.250%	FHLB-Callable Coupon	04/22/15	04/22/16	10/22/18	1,000,000	1,000,000	1,000,090	Custodian
1.300%	1.300%	1.300%	FHLB-Bullet	03/30/15		10/30/18	1,000,000	1,000,000	1,010,150	Custodian
1.500%	1.500%	1.500%	FHLB-Callable Coupon	03/13/15	03/13/17	03/13/19	1,000,000	1,000,000	1,004,180	Custodian
1.500%	1.500%	1.500%	FHLB-Callable Coupon	07/22/15	07/22/16	04/22/19	1,000,000	1,000,000	1,001,820	Custodian
1.550%	1.550%	1.550%	FNMA-Callable Coupon	12/10/15	06/10/16	06/10/19	1,000,000	1,000,000	1,000,820	Custodian
1.600%	1.600%	1.600%	FNMA-Callable Coupon	05/19/15	05/19/17	05/19/20	1,000,000	1,000,000	1,002,920	Custodian
1.150%	1.150%	1.150%	FFCB-Callable Coupon	02/23/16	05/23/16	11/23/18	1,000,000	1,000,000	1,000,010	Custodian

LVMWD Investment Report for the Month Ending March 31, 2016

Disc./Cpn Rate	Yield To Maturity	Yield To Call	Investment Type	Date Invested	Date Matures	Book Value	Par Value	Market Value	Market Value Source
Investments Maturing After Six Months (continued):									
1.500%	0.983%		FHLB-Bullet	02/09/16	03/08/19	1,015,650	1,000,000	1,016,560	Custodian
1.350%	1.350%	1.350%	FNMA-Callable Coupon	02/26/16	08/26/16	1,000,000	1,000,000	998,060	Custodian
1.375%	1.375%	1.376%	FHLMC-Callable Coupon	01/28/16	10/28/16	1,000,000	1,000,000	1,001,310	Custodian
1.300%	1.300%	1.300%	FNMA-Callable Coupon	02/24/16	02/24/17	1,000,000	1,000,000	998,440	Custodian
2.250%	1.732%		CONNECTICUT ST-MuniBo	02/17/16	09/01/20	1,119,648	1,095,000	1,114,579	Custodian
2.427%	1.779%		NEWSCD-MuniBond	03/17/16	08/01/20	934,688	910,000	935,526	Custodian
			Sub-Total			30,671,656	30,590,000	30,695,111	
			Total Investments			30,671,656	\$30,590,000	30,695,111	

Note: Gov. Agency Coupon Notes will distribute interest every six month.

1-CPNRT=0.75% to 5/16; 1% to 5/17; 2% to 11/17; thereafter 3%.

Interest earnings for the month were as followed:

Refunding Revenue Bonds - Reserve Fund (Bank of New York Mellon)	Amount Earned/Accrued	Current Yield
Investments	\$1,074	0.506%
Local Agency Investment Fund (LAIF)	31,880	1.180%
CalTrust Short-Term Fund	10,754	0.506%
Blackrock Liquidity Fund - US Treasury Money Market Fund (Union Bank)	1,163	0.480%
Sweep Accounts (Wells Fargo Bank/Bank of New York Mellon)	1	0.020%
	10	0.010%
	<u>\$44,882</u>	

Total Earnings

Schedule of Investment Balance Limitations (Per District investment policy)

The source of the market valuation is as followed:

Investments (Note 1)	Total Amount Invested	% of Total	Max. Limit Allowed
Refunding Revenue Bonds - Reserve Fund (Bank of New York Mellon/LAIF)	\$30,671,656	47.83%	no limit
Blackrock Liquidity Fund - US Treasury Money Market Fund (Union Bank)	2,760,955	4.31%	1 yr debt pmt.
Local Agency Investment Fund (LAIF)	39,330	0.06%	no limit
CalTrust Short-Term Fund	28,633,594	44.66%	50,000,000
	2,011,890	3.14%	no limit
	<u>\$64,117,425</u>	<u>100.00%</u>	
	(Note 2)		
Total			

Note 1: The average weighted duration for investments, excluding LAIF, is 804 days, which is under the assumption that callable coupons will not be called and will be held until maturity.

Note 2: In March 2016, Joint Powers Authority's participation in investment is \$5,411,010.35, of which \$3,672,686.64 (or 67.87%) belongs to LV.

LVMWD Investment Report for the Month Ending March 31, 2016

Bank Account Balances as of March 31, 2016:

Bank Name	Account Type	Amount
Wells Fargo Bank	Checking	\$131,619 (Note 3)
Wells Fargo Bank	Sweep	702,835
Bank of New York Mellon	Money Market	75
	Total	\$834,529

Note 3: This is bank balance without adjusting for outstanding checks. The total amount of outstanding checks is unavailable at the time of reporting.

"All District investments are included in this report and all investments, except those relating to debt issues and deferred compensation programs funds, conform to District investment policy. All investment transactions within the period covered by this report, except for the exceptions noted above, conform to District investment policy. Deferred compensation program funds are not included in this report; their investment is directed by individual employees participating in the deferred compensation program and not by the District. Debt issue funds are included in this report; their investment is controlled by specific provisions of the issuance documents and not by the District."

"The deposits and investments of the District safeguard the principal and maintain the liquidity needs of the District, providing the District with the ability to meet expenditure requirements for the next six months. The maturity dates are compatible with foreseeable cash flow requirements. The deposits and investments can be easily and rapidly converted into cash without substantial loss of value."

Approved for April 26, 2016 Agenda:

David W. Pedersen, General Manager

I HEREBY CERTIFY THAT THE FOREGOING IS TRUE AND CORRECT
TO THE BEST OF MY KNOWLEDGE

Jay Lewitt, Treasurer

Definitions

- Disc./Cpn Rate – The yield paid by a fixed income security.
- Yield to Maturity – The rate of return of a security held to maturity when interest payments, market value and par value are considered.
- Bullet – A fixed income security that cannot be redeemed by the issuer until the maturity date.
- Callable – A fixed income security that can be redeemed by the issuer before the maturity date.
- Book Value – The price paid for the security.
- Par Value – The face value of a security.
- Market Value – The current price of a security.
- Custodian – The financial institution that holds securities for an investor.

Investment Abbreviations

- FHLB – Federal Home Loan Bank
- FHLMC – Federal Home Loan Mortgage Corporation (Freddie Mac)
- FNMA – Federal National Mortgage Association (Fannie Mae)
- FFCB – Federal Farm Credit Bank
- Bonds
 - NYCGEN – New York City Transitional Finance Authority Future Tax Secured Bond
 - KYSHSG – Kentucky State Housing
 - Montgomery – Montgomery, AL General Obligation Bond
 - PORTRN – Port Authority of New York & New Jersey Revenue Bond
 - AZSHGR – Arizona Board of Regents University of Arizona System Revenue Bond
 - LVNSCD – Las Virgenes Unified School District
 - NJSMFH – New Jersey State Mortgage Finance & Housing
 - PTS – Port of Seattle
 - ARLDEV – Arlington County Development Authority Revenue Bond

LVMWD CASH & INVESTMENT ANALYSIS - March 31, 2016

	Restricted Cash	Cash Held by Policy	Policy Requirement	Over (Short) Policy
101 - Potable Water Operations		849,388	8,245,415	(7,396,027)
201 - Potable Water Construction	53,014	3,999,374	4,360,000	(360,626)
301 - Potable Water Replacement		<u>5,300,000</u>	<u>8,000,000</u>	<u>(2,700,000)</u>
603 - Rate Stabilization Fund	53,014	10,148,762	20,605,415	(10,456,653)
Total Potable Water				
102 - Recycled Water Operations		10,053,212	1,066,799	8,986,413
203 - Recycled Water Construction	1,050,488	<u>4,311,918</u>	<u>200,000</u>	<u>4,111,918</u>
302 - Recycled Water Replacement	1,050,488	14,365,130	1,266,799	13,098,331
Total Recycled Water				
130 - Sanitation Operations		16,374,105	2,859,496	13,514,609
230 - Sanitation Construction	45,867	<u>3,585,489</u>	<u>4,600,000</u>	<u>(1,014,511)</u>
330 - Sanitation Replacement	45,867	19,959,594	7,459,496	12,500,098
Total Sanitation				
606 & 607 - Refunding Revenue Bonds - Reserve Fund	2,761,030			
701 - Vested Sick Leave Reserve	1,315,196			
720 - Insurance Reserve	5,567,918	3,311,842	3,300,587	11,255
JPA	6,197,480			
Prepaid Connection Fees				
<i>Subtotal</i>	<u>16,990,993</u>	<u>47,785,327</u>		
TOTAL		64,776,321		

Financial Policy - Cash required to comply with District's adopted Financial Policy.

Restricted Cash - Revenue restricted to a particular purpose.

Bond Covenants - Money relating to bond financing that is restricted in use and required by promises made in bond documents. Funds are reconciled at year-end.

WATER SUPPLY CONDITIONS CRA

As of: 04/17/2016

2016 Colorado River

865,000 AF
69% of full CRA
 Does not include storage withdrawals or exchanges

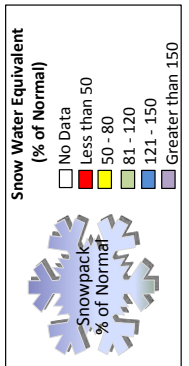
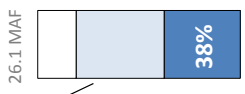
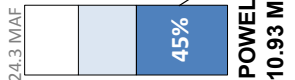
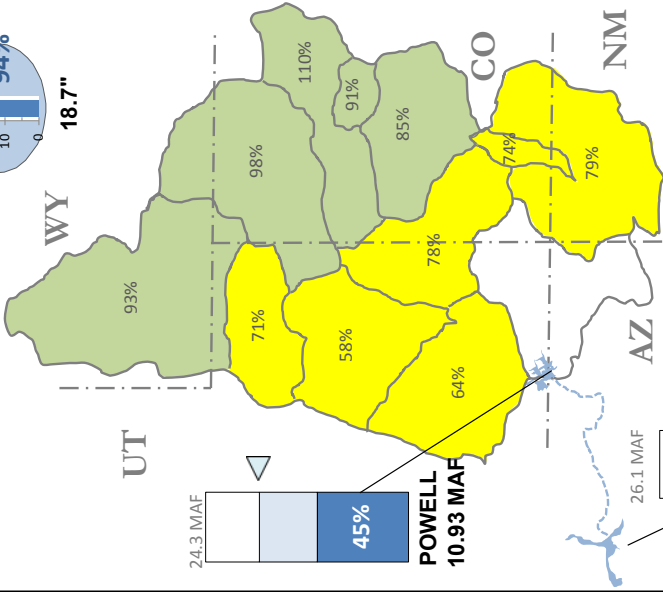
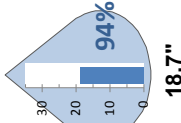
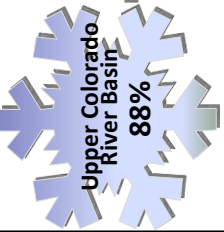

1997-98 vs. 2015-16 El Niño Signal

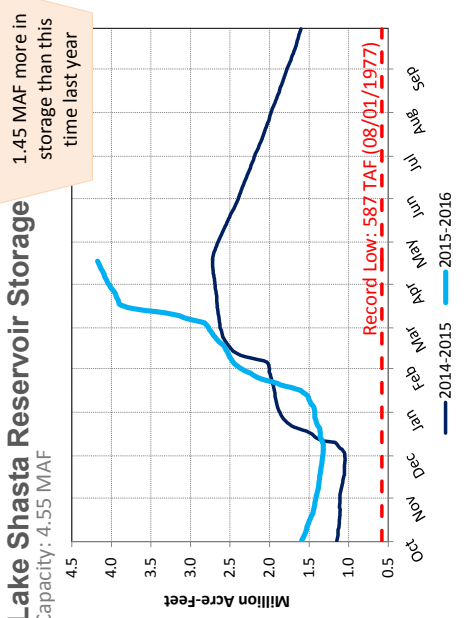
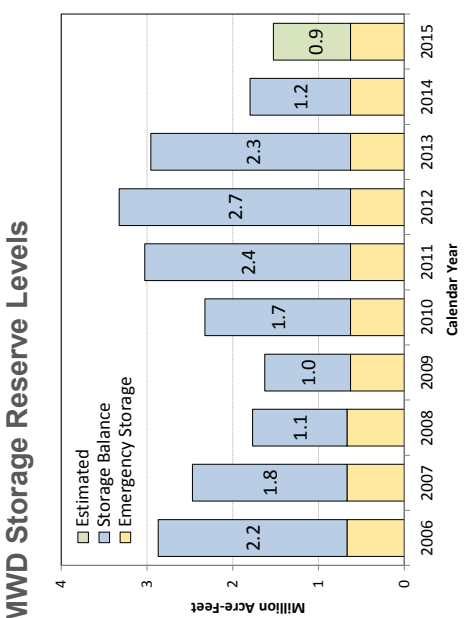
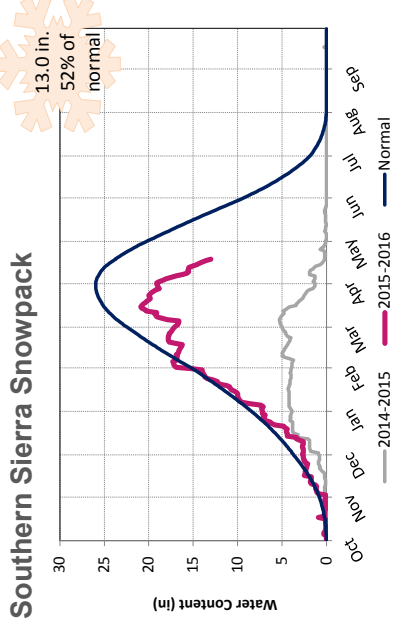
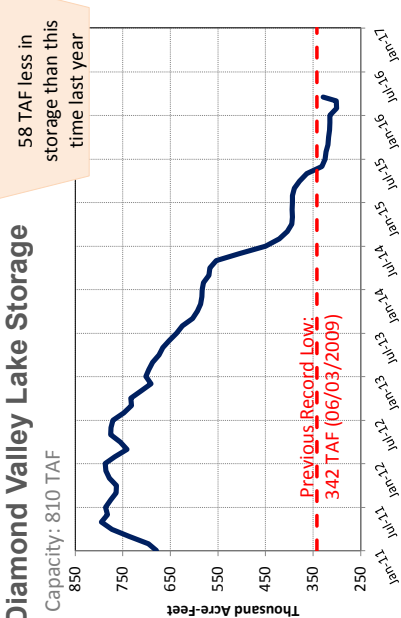
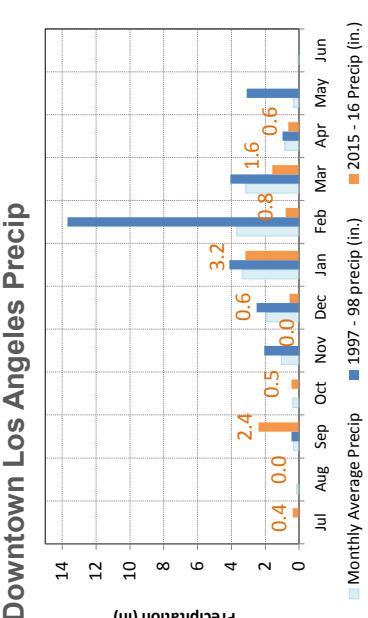
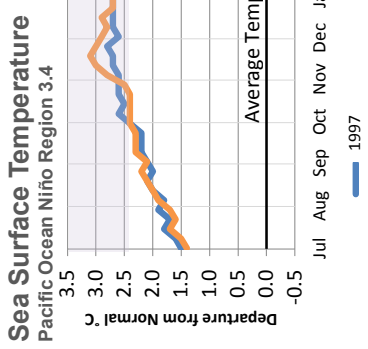

This report is produced by the Water Resource Management group and contains information from various federal, state, and local agencies. The Metropolitan Water District of Southern California cannot guarantee the accuracy or completeness of this information. Readers should refer to the relevant state, federal, and local agencies for additional or the most up to date water supply information. Reservoirs, lakes, aqueducts, maps, watersheds, and all other visual representations on this report are not drawn to scale.

<http://www.mwdh2o.com/WSCR>

WATER SUPPLY CONDITIONS SWP

As of: 04/17/2016

2016 SWP Allocation

860,175 AF
45% of Table A

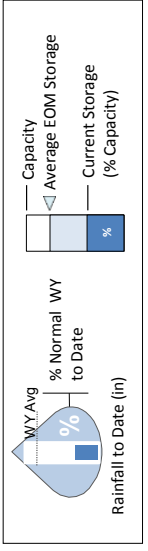
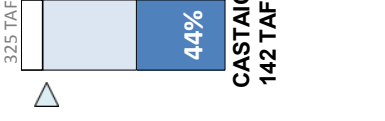
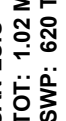
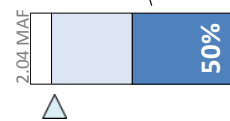
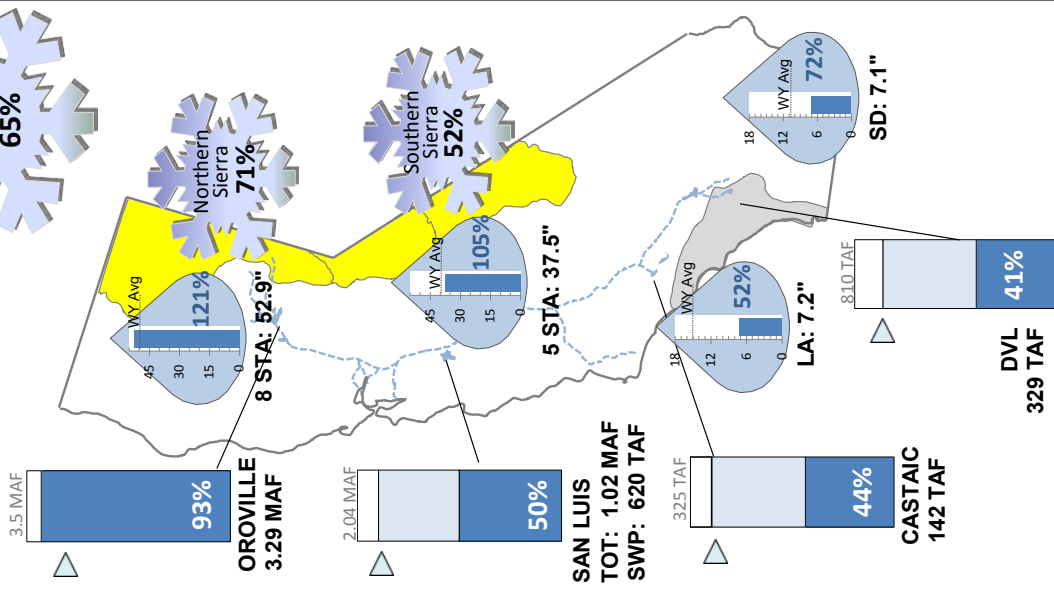

State Water Project Resources

Colorado River Resources

As of: 04/17/2016

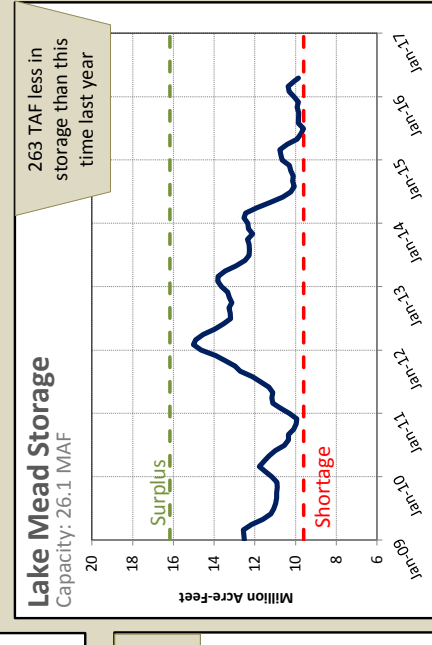
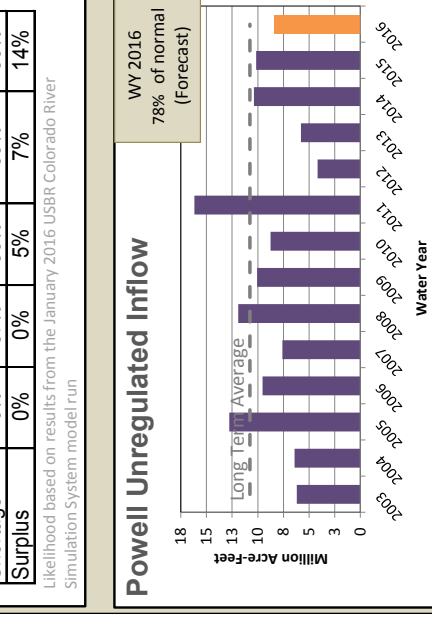
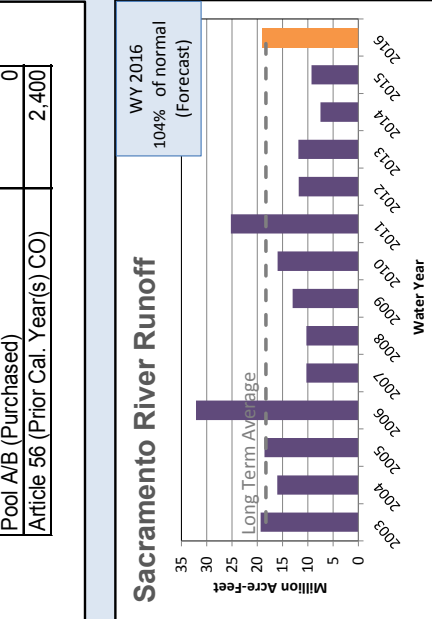
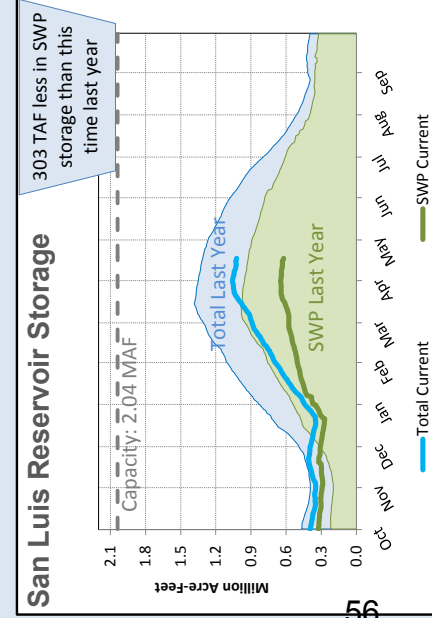
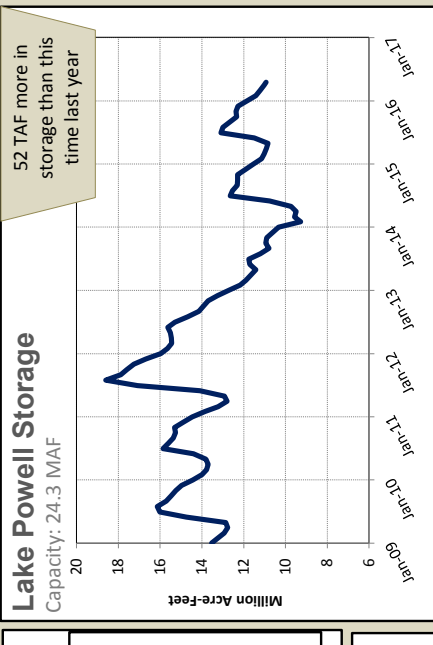
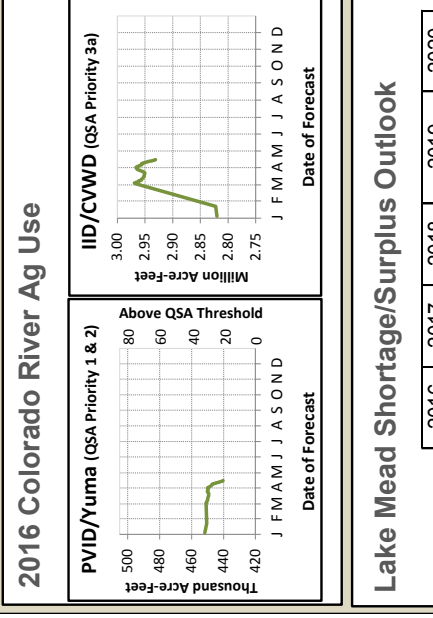
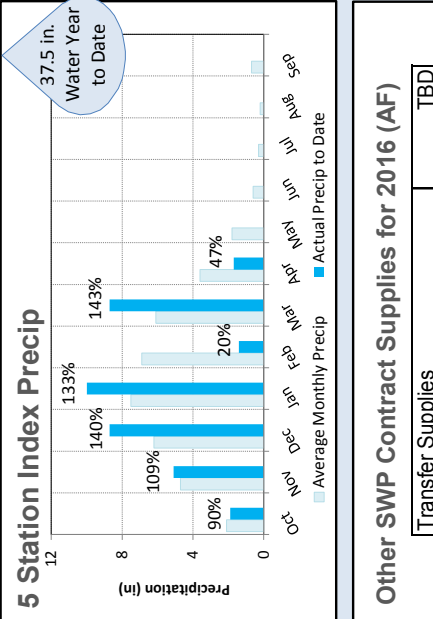
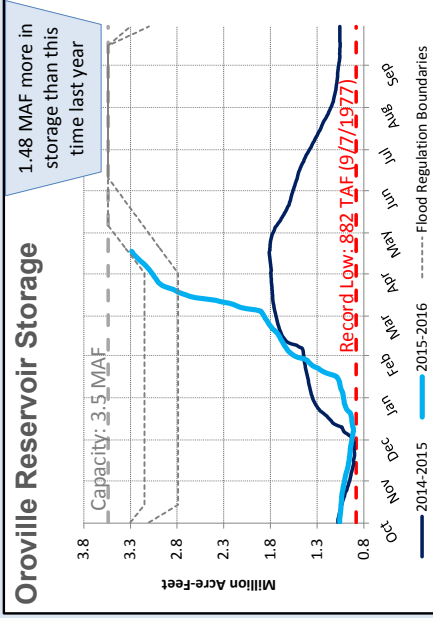
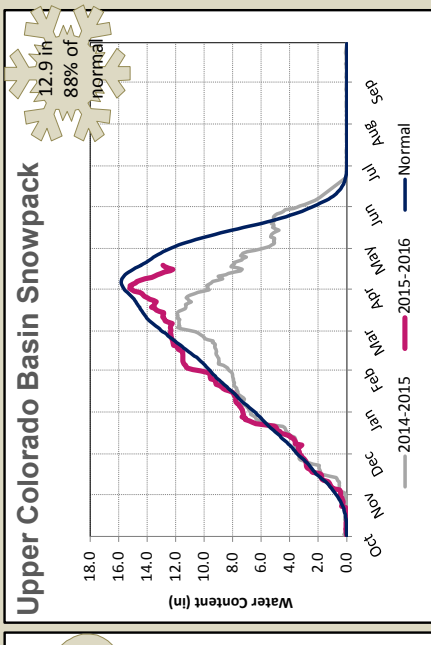
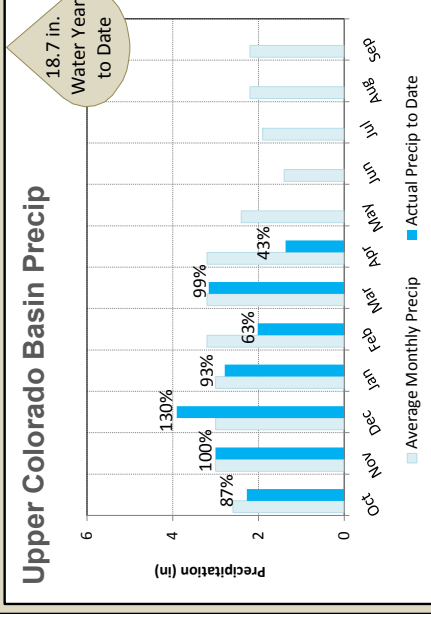
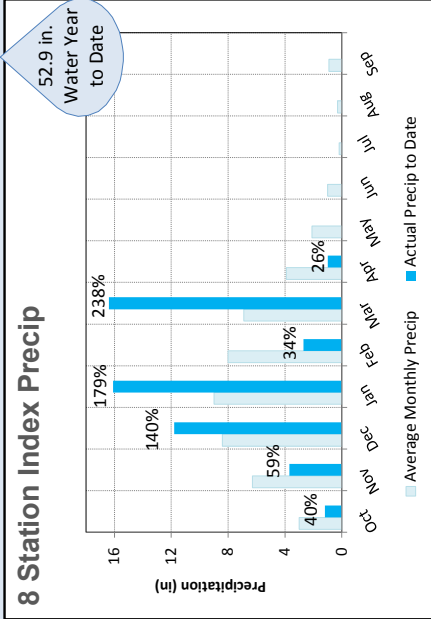
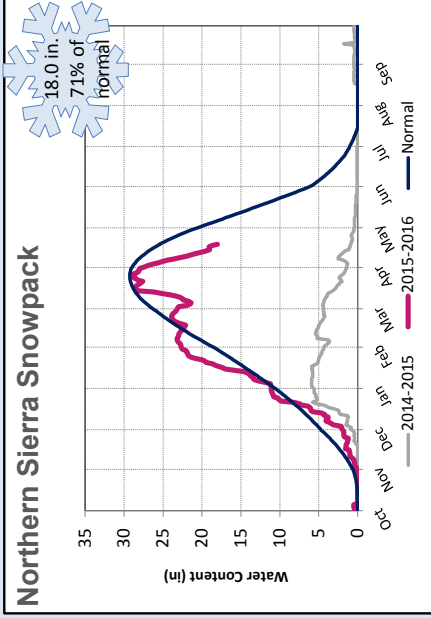



Drought Update

Thursday, April 14, 2016

CURRENT DROUGHT CONDITIONS

- **Drought Outlook:** As California's traditional wet season draws to a close this month, California continues to experience a fifth year of drought conditions. Rain and snow levels this winter certainly improved from recent years, but not enough to draw the state out of the current drought. This winter, rain and snow levels varied significantly by region, with parts of Northern California receiving better than average precipitation while most of Southern California received below average precipitation. The state will continue to respond to drought conditions throughout the state in the coming months.
- **Recent Precipitation:** Over the weekend, several weather systems moved through the state with the highest amounts of average rainfall in the Central and Southern Sierra ranging from 0.94 to 2.1 inches. Additional areas that received precipitation include 0.35 to 0.84 inches in the Bay Area, and 0.52 to 1.41 inches in the San Joaquin Valley.

Below are precipitation totals (in inches) from April 1 through April 13, and year-to-date rainfall based on the water year cycle (October 1, 2015 to September 30, 2016).

- | | |
|--|---|
| • Bakersfield: 0.77" (4.68") | • Redding: 0.28" (32.13") |
| • Paso Robles: 0.09" (7.30") | • Riverside: 0.24" (4.91") |
| • Fresno: 0.95" (13.82") | • Sacramento: 0.38" (15.10") |
| • Yosemite: 0.96" (33.28") | • San Diego: 0.45" (7.29") |
| • Los Angeles: 0.19" (6.30") | • Mount Shasta: 0.76" (36.27") |
| • Stockton: 1.78" (15.20") | • South Lake Tahoe: 0.91" (18.59") |
| • San Francisco: 0.67" (21.18") | • Monterey: 0.32" (20.96") |

- **Weather Outlook:** The next weather system is expected to move into Northern California by Wednesday night into Thursday. Warm and dry conditions will return to the area by the weekend. Dry weather will prevail in Southern California through Wednesday with slight warming. Thursday will be partly cloudy and cooler through Friday, with clear skies and warmer temperatures expected through the weekend.
- **Snow Survey:** The latest [manual snowpack survey](#), conducted on March 30, recorded California snowpack at 87 percent of normal to date. Regionally, the Northern Sierra Nevada is at 97 percent of average to date, the Central Sierra is at 88 percent of average to date, and the Southern Sierra Nevada is at 72 percent of average to date.

As of April 11, a more recent update using the [automated snow sensors](#) show snowpack conditions across the state now stand at 70 percent of normal. Regionally, the Northern Sierra is at 75 percent of average to date, Central Sierra is at 76 percent of average to date, and the Southern Sierra is at 60 percent of average to date.

- **Projected Reservoir Management:** Since the last report on April 1, Central Valley reservoirs from Shasta and Trinity in the North to Isabella in the South had a net gain in storage of 335,812 acre-feet (AF), with a total gain of 385,025 AF and a total loss of 50,213 AF. Shasta Reservoir increased by 61,148 AF, while San Luis Reservoir, an off-stream reservoir for the Central Valley Project and State Water Project, decreased its storage by 15,059 AF.
- [Reservoir Levels](#) as of April 13 have increased, including: Castaic Lake 44% of capacity (49% of year to date average); Don Pedro 64% of capacity (87% of average); Exchequer 40% of capacity (70% of average); Folsom Lake 79% of capacity (115% of average); Lake Oroville 92% of capacity (117% of average); Perris Lake 36% (43% of average); Millerton Lake 58% of capacity (83% of average); New Melones 27% of capacity (42% of average); Pine Flat 44% of capacity (75% of average); San Luis 50% of capacity (56% of average); Shasta Reservoir 91% of capacity (109% of average); and Trinity Lake 57% of capacity (71% of average). An update of water levels at other [smaller reservoirs](#) is available.
- **Dry Well Reports:** As California faces the fifth year of drought, the Governor's Drought Task Force continues to monitor and identify communities and local water systems in danger of running out of water. In 2015, a cross-agency team, led by the Department of Water Resources (DWR), developed a new system that improves and streamlines data collection and reporting for [household water shortages](#) for California water systems with fewer than 15 household connections.

As of April 7, approximately 2,180 wells statewide have been identified as critical or dry, affecting an estimated 10,900 residents. Cal OES reported that 1,988 of the 2,180 dry wells are concentrated in the inland regions within the Central Valley. If you are experiencing a water supply shortage, please [submit a report](#) on DWR's website.

- **Vulnerable Water Systems:** The State Water Board continues to provide technical and funding assistance to several communities facing drinking water shortages, and is monitoring water systems across the state. Since January 2014, 113 out of the 151 projects approved to receive emergency funding for interim replacement drinking water have been executed. On May 19, 2015, the State Water Board adopted Guidelines for administering the latest emergency drought appropriations of \$19 million announced this past March. To date, the State Water Board has received requests for \$14 million of those funds.

- **Fire Activity:** Since the beginning of the year, firefighters from CAL FIRE and the U.S. Forest Service have responded to over 365 wildfires across the state, burning 131 acres. Fire activity across California is low resulting in 62 combined wildfires in just the past week.
- **CAL FIRE Burn Suspension Status:** Due to cooler temperatures and recent rains, CAL FIRE has lifted the burn suspension in the State Responsibility Area in Northern California and portions of Central California, allowing residential outdoor burning of landscape debris with a permit.

CAL FIRE continues to monitor weather conditions closely and has the ability to increase staffing should the weather conditions change or if there is a need to support wildfire activity and any other emergencies in the State. For additional information on preparing for and preventing wildfires, please visit <http://www.readyforwildfire.org/>.

KEY ACTION ITEMS FROM THIS WEEK

- **Californians Save 1.19 Million Acre-Feet of Water, Enough to Supply Nearly 6 Million People for a Year:** On April 4, the State Water Board [announced](#) that Californians saved nearly 1.19 million acre-feet of water from June 2015 through February 2016. Overall, Californians just missed Governor Brown's 25 percent water conservation mandate by cumulatively saving 23.9% compared with the same months in 2013. The State Water Board indicated that the water saved during that period is enough to supply 5.9 million residents within California during a one-year period.
- **State Water Board Releases New Conservation Standards:** On April 7, the State Water Board [released](#) new water conservation standards for many urban water suppliers that reflect adjustments and credits of up to eight percentage points. The new conservation standards are authorized by the revised Emergency Regulation for Statewide Urban Water Conservation which was adopted in [February 2016](#) to ensure that urban water conservation continues throughout the year. The regulation extends restrictions on urban water use through October 2016 while providing urban water suppliers more flexibility in meeting their conservation requirements.
- **State Water Board to Host April 20 Workshop on Urban Water Conservation Regulation:** On March 23, the State Water Board [announced](#) that a [public workshop](#) will be held on April 20 to discuss potential modifications to the current Emergency Regulation for Statewide Urban Water Conservation. For more information, visit the State Water Board's [Water Conservation Portal – Emergency Conservation Regulation](#).

- **State Water Project Allocation Increases to 45 Percent:** On March 17, the Department of Water Resources (DWR) [increased](#) its water delivery estimate allocation for the State Water Project (SWP) from 30 percent in February to 45 percent. March storms have increased some of the state's major reservoir levels to slightly above historic levels which prompted the increase in delivery allocations.
- **CDFW Monitors Effect of Severe Drought on Wildlife:** On March 10, the California Department of Fish and Wildlife (CDFW) [released](#) a comprehensive assessment that identifies and analyzes the vulnerability of California wildlife impacted by the drought. CDFW biologists report that amphibian, reptile, bird and mammal populations that depend on freshwater marsh, streamside habitat and wet meadows are struggling most to endure the drought.

In addition, CDFW biologists ranked the vulnerability of the state's terrestrial species and identified 48 species that need additional monitoring and assistance. The greatest concentrations of these high-risk populations are found in Southern California coastal, mountain and valley regions, the Sierra Nevada mountain range, the Mojave Desert, Central Valley and the southern Cascade mountain range. For more information about drought related actions to preserve and protect the state's fish and wildlife resources, visit the CDFW [Drought Portal](#).

- **Bureau Announces Initial Water Supply Allocation for CVP:** On April 1, the U.S. Bureau of Reclamation (Bureau) [announced](#) the initial 2016 water supply allocation for the Central Valley Project (CVP). This allocation is based on the amount of water that will be available for delivery to CVP water users and reflects current reservoir storages, precipitation and snowpack in the Central Valley and Sierra Nevada.

Due to improved drought conditions in Northern California, north-of-Delta contractors have been allocated 100% of their contract supply, while south-of-Delta agricultural contractors have been allocated 5 percent, and eastside contractors have received a zero allocation this year. For more information, view the full press release on the Reclamation [News & Multimedia Portal](#).

- **California's Water Conservation Education Program Campaign:** On March 30, Save Our Water and the Department of General Services [launched](#) the [Water-Smart Renovation Project](#) in Capitol Park with a mulching demonstration on the East steps of the State Capitol. The renovation project will also include turf removal and numerous water efficiency measures and is expected to be complete by the summer. Once implemented, the renovations are expected to save more than 1.6 million gallons of water a year.

Save Our Water continues to promote the “[Claim your Turf Replacement](#)”, and “[Claim Your Toilet](#)” rebate programs. For more tips and tools to help conserve water and keep trees healthy during the drought, please visit Save Our Water’s website, which is available in both [English](#) and [Spanish](#), or connect with the program on [Facebook](#), [Twitter](#) or [Instagram](#).

- **Governor’s Drought Task Force:** The Task Force continues to take actions that conserve water and coordinate state response to the drought. During the April 7 meeting, the Task Force provided updates on water conditions, water operations and environmental habitat, water conservation, and drought impacts and response efforts. In addition, the California Department of Public Health provided an overview of drought-related community impacts surveyed in Tulare and Mariposa County.

ONGOING DROUGHT SUPPORT

- **Emergency Food Aid, Utility and Employment Assistance:** The Department of Social Services (CDSS) Drought Food Assistance Program (DFAP) provides food assistance to affected communities that suffer high levels of unemployment from the drought. To date, over 1,272,786 boxes have been provided to community food banks in drought-impacted counties, with an average of approximately 13,250 food boxes per week since June 2014. Approximately 1,145,086 boxes of food have been picked up by 588,491 households.

Food boxes distributions vary by county and occur 1-4 times per month. This past week, nearly 46% of the food distributions have occurred in the Tulare Basin (Fresno, Kern, Kings and Tulare). An estimated 12,000 boxes are scheduled for delivery to Fresno, Kern, Riverside, San Joaquin, and Tulare for the week ending April 15.

The Labor Workforce Development Agency announced that the federally funded Drought Temporary Jobs program has enrolled 1,150 participants at 189 worksite projects in 15 counties. The program is funded through the U.S. Department of Labor’s National Dislocated Worker Grant program which offers 6 months of employment on drought-related public works projects for up to 1,000 workers affected by the drought.

The Department of Community Services and Development (CSD) is in the process of allocating \$400,000, under CSBG, to support the Migrant and Seasonal Farmworker (MSFW) drought assistance program which provides assistance in employment training and placement services to individuals impacted by the drought. To date, CSD has expended a total of \$349,425 and has assisted 111 participants in employment training and placement services.

In response to California's historic drought, CSD has received \$7.5 million in General Fund to implement the Drought Emergency Assistance Program (DEAP) to provide emergency relief and support services to drought-impacted individuals and their families and households. As of March 31, approximately \$6.4 million has been issued to 4,776 households.

- **Drought Response Funding:** The \$687 million in state drought funding that was appropriated in March 2015 through emergency legislation, as well as \$142 million provided in the 2014 Budget Act, continues to advance toward meeting critical needs. In 2015, \$468 million has been committed, and nearly \$625 million of the emergency funds appropriated in March came from sources dedicated to capital improvements to water systems. Since March 2015, the Department of Water Resources has expedited grant approvals, getting \$21 million immediately allocated to grantees that were pre-approved for certain projects.

As planned in March 2015, the next \$200 million of expedited capital funding was awarded last October, and the remaining \$250 million will be granted by fall 2015. The 2014 Budget Act appropriated an additional \$53.8 million to CAL FIRE over its typical budget to enhance firefighter surge capacity and retain seasonal firefighters beyond the typical fire season.

As a result of continuing drought conditions, emergency legislation was enacted in March 2015 that appropriated over \$1 billion of additional funds for drought-related projects and activities. The Administration's May Revision proposal includes an additional \$2.2 billion for programs that protect and expand local water supplies, improve water conservation, and provide immediate relief to impacted communities.

Local Government

- **Local Emergency Proclamations:** A total of 60 local Emergency Proclamations have been received to date from city, county, and tribal governments, as well as special districts:
 - **26 Counties:** Butte, Colusa, Calaveras, El Dorado, Fresno, Glenn, Inyo, Kern, Kings, Madera, Mariposa, Merced, Modoc, Plumas, San Bernardino, San Joaquin, San Luis Obispo, Santa Barbara, Shasta, Siskiyou, Stanislaus, Sutter, Trinity, Tulare, Tuolumne, and Yuba.
 - **12 Cities:** City of Live Oak (Sutter County), City of Lodi (San Joaquin County), City of Manteca (San Joaquin County), City of Montague (Siskiyou County), City of Porterville (Tulare County), City of Portola (Plumas County), City of Ripon (San Joaquin County), City of Santa Barbara (Santa Barbara County), City of Rancho Cucamonga (San Bernardino County), City of West Sacramento (Yolo County), City of Willits (Mendocino County) and the City of Fort Bragg (Mendocino County).

- **10 Tribes:** Cortina Indian Rancheria (Colusa County), Hoopa Valley Tribe (Humboldt County), Karuk Tribe (Siskiyou/Humboldt Counties), Kashia Band of Pomo Indians of the Stewarts Point Rancheria (Sonoma County), Picayune Rancheria of Chukchansi Indians (Madera County) Sherwood Valley Pomo Indian Tribe (Mendocino County), Tolowa Dee-ni' Nation (Del Norte County), Tule River Indian Tribe (Tulare County), Yocha Dehe Wintun Nation (Yolo County), and Yurok Tribe (Humboldt County).
- **12 Special Districts:** Carpinteria Valley Water District (Santa Barbara County), Goleta Water District (Santa Barbara County), Groveland Community Services District (Tuolumne County), Lake Don Pedro Community Services District (Mariposa Stanislaus County), Mariposa Public Utility District (Mariposa County), Meiners Oaks Water District (Ventura County), Montecito Water District (Santa Barbara County), Mountain House Community Service District (San Joaquin County), Nevada Irrigation District (Nevada County), Placer County Water Agency (Placer County), Tuolumne Utilities District (Tuolumne County), and Twain Harte Community Services District (Tuolumne County).
- **Water Agency Conservation Efforts:** The Association of California Water Agencies (AWCA) [has identified](#) several hundred local water agencies that have implemented water conservation actions. These water agencies [are responding to the drought](#) by implementing conservation programs, which include voluntary calls for reduced water usage and mandatory restrictions where water shortages are worst.

ACWA [released](#) a Drought Response Toolkit to assist water agencies as they take action to meet state-mandated water conservation target and communicate information about water use restrictions, enforcement and other issues with their customers, media and other audiences.

- **County Drought Taskforces:** A total of 33 counties have established drought task forces to coordinate local drought response. These counties include: Butte, Colusa, Glenn, Humboldt, Kern, Kings, Lake, Madera, Mendocino, Merced, Modoc, Monterey, Napa, Nevada, Orange, Placer, Plumas, Sacramento, San Francisco, San Joaquin, San Luis Obispo, San Mateo, Santa Barbara, Santa Clara, Siskiyou, Stanislaus, Solano, Sutter, Tehama, Trinity, Tulare, Tuolumne, and Yolo.
- **Tribal Taskforce:** A total of 7 tribes have established drought task forces to coordinate tribal drought response. These tribes include: Hoopa Valley Tribe (Humboldt County), Hopland Tribe (Mendocino County), Karuk Tribe (Siskiyou County), La Jolla Band of Luiseno Indians (San Diego County), Sherwood Valley Tribe (Mendocino County), Trinidad Tribe (Humboldt County), and Yurok Tribe (Humboldt and Del Norte County).

DROUGHT RELATED WEBSITES FOR MORE INFORMATION

[Drought.CA.Gov](#): California's Drought Information Clearinghouse

State's Water Conservation Campaign, [Save Our Water](#)
Local Government, [Drought Clearinghouse and Toolkit](#)

California Department of Food and Agriculture, [Drought Information](#)
California Department of Water Resources, [Current Water Conditions](#)
California Data Exchange Center, [Snow Pack/Water Levels](#)
California State Water Resources Control Board, Water Rights, [Drought Info and Actions](#)
California Natural Resources Agency, [Drought Info and Actions](#)
State Water Resources Control Board, Drinking Water, [SWRCB Drinking Water Program](#)
California State Water Project, [Information](#)

[U.S. Drought Monitor](#) for Current Conditions throughout the Region
[U.S. Drought Portal](#), National Integrated Drought Information System (NIDIS)
National Weather Service [Climate Predictor Center](#)
USDA Drought Designations by County [CA County Designations](#)
USDA Disaster and Drought Assistance Information [USDA Programs](#)
U.S. Small Business Administration Disaster Assistance Office



April 26, 2016 LVMWD Regular Board Meeting

TO: Board of Directors

FROM: Facilities & Operations

Subject : Las Virgenes-Calleguas Interconnection Project: Memorandum of Understanding for Proposition 84 Integrated Regional Water Management Program Implementation Grant

SUMMARY:

The District was awarded a Proposition 84 Integrated Regional Water Management Program (IRWMP) Implementation Grant, in the amount of \$1,975,517.16, for the Las Virgenes-Calleguas Interconnection Project, including extension of a recycled water main to Canyon Oaks Park in Westlake Village. The grant funds are provided by the California Department of Water Resources through the Los Angeles County Flood Control District (LACFCD), the local agency responsible for administering the funding for the Greater Los Angeles IRWMP Region. Staff requests authorization to execute a Memorandum of Understanding to define the relationship between the District and LACFCD for the purpose of receiving the grant funding.

RECOMMENDATION(S):

Authorize the General Manager to execute a Memorandum of Understanding with the Los Angeles County Flood Control District, in a form approved by District Legal Counsel, for a Proposition 84 Integrated Regional Water Management Program Implementation Grant for the Las Virgenes-Calleguas Interconnection Project.

FISCAL IMPACT:

Yes

ITEM BUDGETED:

Yes

FINANCIAL IMPACT:

This grant will provide \$1,975,517.16 in funding for the project.

DISCUSSION:

Attached for reference is a draft of the Memorandum of Understanding.

GOALS:

Ensure Effective Utilization of the Public's Assets and Money

Prepared by: David R. Lippman, P.E., Director of Facilities and Operations

ATTACHMENTS:

Draft Memorandum of Understanding

MEMORANDUM OF UNDERSTANDING [DRAFT]

THIS MEMORANDUM OF UNDERSTANDING (hereinafter referred to as "Agreement"), is made and entered into as of the date of the last Party signature set forth below between the LOS ANGELES COUNTY FLOOD CONTROL DISTRICT (hereinafter referred to as "LACFCD"), and **Las Virgenes Municipal Water District** (hereinafter referred to as "Local Project Sponsor" or "LPS"). LACFCD and LPS are hereinafter referred to as "Parties" or, each individually, as "Party" for the following project(s): **Las Virgenes – Calleguas Municipal Water Districts Interconnection Project** (hereinafter referred to as "Project(s)"). The requested grant amount for the Project(s) is **\$XXX,XXX.XX**.

W I T N E S S E T H

WHEREAS, in November 2006, the voters of California enacted the Safe Drinking Water, Water Quality and Supply, Flood Control, River and Coastal Protection Bond Act, (hereinafter referred to as Proposition 84), adding provisions to the California Public Resources Code; and

WHEREAS, Proposition 84 amended the Public Resources Code to include Section 75026 et seq., which authorizes the Legislature to appropriate One Billion and 00/100 Dollars (\$1,000,000,000.00) for Integrated Regional Water Management (hereinafter referred to as "IRWM") projects (water resources-related projects that address water supply, water quality, and habitat/open space needs in a region); and

WHEREAS, the intent of the IRWM concept is to encourage integrated regional strategies for the management of water resources and to provide funding through competitive grants for projects that protect communities from drought, improve water reliability, protect and improve water quality, and improve local water security by reducing dependence on imported water; and

WHEREAS, the California Department of Water Resources (hereinafter referred to as "DWR") issued Proposition 84 IRWM Grant Program Guidelines for the 2015 IRWM Grant Program Guidelines and Implementation Grant Proposal Solicitation Package (hereinafter referred to as "Guidelines") in May 2015 to establish the process and criteria to solicit applications, evaluate proposals, and award Proposition 84 grants under the IRWM Grant Program; and

WHEREAS, eligible grant recipients under the Guidelines are public agencies defined as a City, County, City and County, District, joint powers authority, State agency or Department, or other political subdivision of the State, and nonprofit organizations defined as any California corporation organized under Sections 501(c)(3), 501(c)(4), or 501(c)(5) of the Federal Internal Revenue Code. Other entities that are part of the regional water management group responsible for applying for the grant may perform work funded by the grant; and

WHEREAS, under the Guidelines, IRWM Implementation grant proposals must be submitted by an IRWM Region that was accepted into DWR's IRWM Grant Program through the 2009 Region Acceptance Process and must: (1) include projects that are consistent with an adopted IRWM Plan (hereinafter referred to as "Plan"), (2) require project proponents to adopt the Plan or an update to the Plan, (3) describe specific implementation projects for which funding is being requested, and (4) identify matching funding; and

WHEREAS, the Plan for the Greater Los Angeles County Region (hereinafter referred to as "Region"), adopted on December 13, 2006, and updated and approved on August 27, 2014, will facilitate a regional approach to watershed management by establishing collaborative efforts across the watersheds within the Region; and

WHEREAS, the Region was accepted into DWR's IRWM Grant Program through the 2009 Region Acceptance Process in September 2009; and

WHEREAS, the Region's IRWM Group, which includes the Region's participating local entities and the LPSs identified in Exhibit F of the Grant Agreement, designated LACFCD as the regional entity to apply for grant funds on behalf of all proposed projects for the Region, through the IRWM process; and

WHEREAS, the implementation grant proposal for the Region included two (2) separate projects sponsored by the LACFCD and the following local entities, solely or jointly, (the projects are identified in Exhibit F to the Grant Agreement between DWR and LACFCD, which Grant Agreement, including all Exhibits thereto, is attached hereto and incorporated herein as Attachment A): Gateway Water Management Authority (4 separate projects); City of Malibu; Las Virgenes Municipal Water District; Mountains Restoration Trust; City of Calabasas; City of Inglewood; City of Torrance; City of Palo Verdes Estates; National Forest Foundation; The River Project; Glendale Water and Power; Crescenta Valley Water District; City of Monterey Park; and County of Los Angeles; and

WHEREAS, for IRWM projects funded under the implementation grant that will be implemented with the participation of more than one entity, it is the intention of the Parties that the LPS will be a single entity that is responsible for implementation of the Project(s) and which has the authority to enter into this Agreement on behalf of all entities participating in the Project(s); and

WHEREAS, LPS assumes all responsibilities and liabilities for the Project(s) under this Agreement (including the Grant Agreement responsibilities allocated to LPS under this Agreement). LPS will be the entity that invoices LACFCD, submits required information, including reports, notices and notifications, to LACFCD and provides any documentation and information requested or required under this Agreement or the Grant Agreement by LACFCD with respect to the implementation of the Project(s). In the event that the Project(s) will be implemented by more than one entity, LPS shall ensure that it has entered into appropriate written agreement(s) with each of the other Project-implementing entities to confirm the

authority of LPS to enter into this Agreement on their behalf, and shall ensure that each of the other Project-implementing entities agrees to defend, indemnify and hold harmless LACFCD to the same extent as the LPS provides to LACFCD in this AGREEMENT. Further, each entity participating in a Project acknowledges full responsibility for the implementation of the Project(s), including all responsibilities identified in this Agreement as well as the Grant Agreement and commits to the fulfillment of their respective obligations with respect to the Project(s). As to LACFCD, LPS remains solely responsible for all aspects of the Project(s); and

WHEREAS, DWR has indicated that it will award an implementation grant of up to Twenty-Seven Million, Seven Hundred and Forty-Two Thousand, Nine Hundred and Seventy-Five Dollars (\$27,742,975.00) to the LACFCD on behalf of the Region's LPSs; and

WHEREAS, DWR has indicated that it will enter into an agreement (hereinafter referred to as Grant Agreement) with LACFCD, for the administration of the implementation grant funds with respect to the nineteen (19) projects, including LPS's Project(s); and

WHEREAS, LPS desires that LACFCD execute the anticipated Grant Agreement with DWR and perform the role of Grantee therein on LPS's behalf so that LPS can receive and benefit from the Proposition 84 grant funds for its Project(s) in the amount to be identified in Exhibit B to the Grant Agreement; and

WHEREAS, LACFCD and LPS desire to enter into this Agreement to clarify their respective responsibilities with respect to the anticipated grant from DWR and the Parties' responsibilities pursuant to the Grant Agreement; specifically, the Parties intend that LACFCD's role will be to administer the grant funding and submit documentation required under the Grant Agreement to DWR on behalf of LPS, for which LACFCD will be reimbursed pursuant to this Agreement. LPS will be responsible for all other activities required under the Grant Agreement related to its Project(s), including, but not limited to construction, monitoring, Project management, operations and maintenance and legal compliance; and

WHEREAS, the LPS was awarded a project grant of \$XXX,XXX.XX. This amount reflects a 2.5 percent reduction in the LPS's requested grant amount to cover the LACFCD's costs for grant administration and oversight, which are reflected in Project 1 of Exhibit B of the Grant Agreement. The Parties intend by this Agreement to establish that LACFCD will seek reimbursement of its 2.5 percent administrative costs directly from DWR, and that the LPS will not pay or seek reimbursement for these costs; and

WHEREAS, the LPS previously agreed to pay LACFCD **\$15,292.75** for the cost of preparing and processing the LPS's grant application(s) for its project(s). LPS's grant budget includes a line item for this cost; and

WHEREAS the Parties acknowledge that LACFCD will not approve any aspect of the Project(s) or provide any resources related to implementation of the Project(s) outside of grant funding, if any, which is provided to LACFCD from DWR, specifically for the Project(s).

NOW, THEREFORE, LACFCD and LPS hereby agree as follows:

LACFCD'S RESPONSIBILITIES

Section (1) LACFCD AGREES TO, for as long as the Grant Agreement remains in effect:

- (1) Provide staff to oversee grant administration, manage grant funds and provide Project oversight as related to the grant.
- (2) Establish an independent account to manage the grant funds for each Project and provide routine updates to the LPS of balance and activities of each account.
- (3) Receive from LPS and submit to DWR the reports and information prepared and provided by LPS for each Project as requested by LACFCD and/or as required under the Grant Agreement.
- (4) LACFCD may execute amendments to the Grant Agreement on behalf of LPS, upon written request and approval by LPS and after LPS negotiates with DWR.
- (5) Process grant reimbursement requests submitted by LPS, including, submission of such requests to DWR and, only upon receipt of funds from DWR related to the invoices submitted, provide reimbursement to LPS within thirty (30) days of receipt by LACFCD of funds from DWR.
- (6) Submit grant reimbursement request(s) to DWR, for a total amount not to exceed \$XXX,XXX.XX to justify LACFCD's grant administrative costs, management, and project oversight efforts with respect to the IRWM grant, as authorized by DWR and pursuant to Section (2)(8).

LPS'S RESPONSIBILITIES

Section (2) LPS AGREES TO:

- (1) Retain sole and full responsibility for all aspects of LPS's Project(s) as identified in the Grant Agreement, including any approved amendments, including, but not limited to: planning, design, review and approval of plans, specifications, bid documents and construction documents, implementation; construction; management; Project oversight; monitoring; inspections; operation and maintenance; submission of Project reimbursement billing requests; provision of reports, notifications and notices; compliance with all legal requirements related to the Project(s) such as lead agency responsibilities, and all other applicable local, State and Federal statutes and regulations related to the Project(s) for the lifetime of the Project(s) notwithstanding any early termination of this Agreement.
- (2) Plan, design, construct, and continuously operate and maintain LPS's Project(s) pursuant to LPS's Work Plan as identified in Exhibit A to the Grant Agreement. LPS agrees to notify LACFCD and receive LACFCD's written approval as well as that of DWR in

advance of implementing any proposed changes to LPS's Project(s), including proposed future changes to the Work Plan.

- (3) Comply with all terms, provisions and commitments contained in the Grant Agreement, including all exhibits and attachments thereto, applicable to LPS or to LACFCD as Grantee or to representatives of Grantee under the Grant Agreement, whether or not herein specifically referenced, (with the exception of responsibilities identified in Section (1)(1) above which are solely responsibilities of LACFCD) for the lifetime of the Project(s). The Parties agree that responsibilities of LPS, Grantee, representatives of Grantee or activities for which LACFCD (as Grantee) and LPS may be listed as jointly responsible under the Grant Agreement, shall remain the sole responsibility of LPS, with the exception of activities herein listed as LACFCD'S RESPONSIBILITIES.
- (4) Comply with all applicable environmental requirements pertaining to the Project(s), including but not limited to the California Environmental Quality Act (CEQA), the State CEQA Guidelines and, if applicable, the National Environmental Policy Act (NEPA). Submit documents that satisfy the CEQA and NEPA process as well as any mitigation agreements, and environmental permits, including but not limited to DWR's Environmental Information Form. LACFCD is not responsible for any aspect of environmental compliance with respect to the Project(s), including any proposed future changes to LPS's Project(s), and no Project may be implemented absent LPS's compliance with CEQA and other environmental laws and regulations. Prior to submission of each invoice to LACFCD under this Agreement, LPS must submit written confirmation to LACFCD, in a format to be specified by LACFCD, that it has complied with all requirements of the Grant Agreement, including, but not limited to compliance with CEQA and, as applicable, NEPA for LPS's Project(s), including all work covered under the invoice, and shall provide appropriate evidence of its compliance. In addition, LPS agrees to submit written confirmation of CEQA and applicable NEPA compliance prior to implementing any future changes to its Project(s).
- (5) Demonstrate availability of funds to complete the Project by submitting the most recent three (3) years of audited financial statements and provide cost share funding match for the LPS's Project in the amount identified in Exhibit B of the Grant Agreement.
- (6) Ensure that any and all permits, licenses and approvals required for its Project(s) are obtained in a timely manner and maintained in effect as legally required.
- (7) Submit not more than one reimbursement request per month to LACFCD, in the format specified by LACFCD, executed by an authorized individual at LPS who is knowledgeable of the information and certifies and warrants the accuracy of the information contained in the reimbursement request.
- (8) Allow LACFCD to be reimbursed by DWR in an amount not to exceed **\$614,899.89**, representing 2.5 percent of LPS's requested grant amount for grant administrative costs, management, and project oversight efforts with respect to the IRWM, which has been subtracted from the LPS's requested grant amount, as reflected in Project 1 of Exhibit B

of the Grant Agreement. LPS thereby agrees that it will be reimbursed \$XXX,XXX.XX by LACFCD under this Agreement.

- (9) Prepare, provide and ensure accuracy of all deliverables, reports, documentation, notifications, notices and information related to the Project(s) as required under the Grant Agreement and/or requested by LACFCD to assist LACFCD and to enable LACFCD or LPS to provide information required under the Grant Agreement to DWR in a prompt and timely manner, in accordance with the provisions of the Grant Agreement.
- (10) Inform DWR and the LACFCD of any material changes related to the Project(s) as soon as possible including but not limited to, the progress of construction, Project budget(s), and Project benefits, through reporting process or other methods established by DWR and/or the LACFCD.
- (11) Repay the LACFCD any amount owed to DWR within 30 days of written notification, if for any reason DWR determines that LPS's Project(s) is no longer entitled to grant funds.
- (12) Provide regular and ongoing inspections of construction work in progress and be responsible to keep work under control. Authorize LACFCD to inspect the Project(s), at LACFCD's discretion, to review the progress of the Project(s).
- (13) Accept all liabilities and hold LACFCD legally and financially harmless if it is determined by court of law that LPS's allocation and use of the grant and matching funds is in violation of any applicable statutes, regulations, ordinances, guidelines, or requirements, including, but not limited to, grant requirements, and/or requirements governing contracting, and subcontracting, unless such violation(s) is due to LACFCD's active negligence or willful misconduct.
- (14) Accept sole responsibility for persons performing work related to the Project(s), including, but not limited to, employees, contractors, subcontractors, suppliers and providers of services.
- (15) Accept sole responsibility for any and all disputes arising out of contracts for implementation of the Project(s), including, but not limited to, payment disputes involving representatives of LPS, contractors and subcontractors. LPS acknowledges that LACFCD will not mediate or be involved with disputes between LPS and any other entity concerning responsibility for performance of work related to the Project(s).
- (16) Comply with all Basic Conditions, conditions for disbursement, Continuing Eligibility requirements, and Standard Conditions set forth in the Grant Agreement at all times.
- (17) Designate in writing a Project Manager with the full authority to act on behalf of LPS on any matter related to the Project(s), and advise LACFCD and DWR immediately in writing of any change in Project Manager.

Section (3) TERMINATION OF AGREEMENT

- (1) This Agreement shall remain in effect while the Grant Agreement or any provision of the Grant Agreement remains in effect. LPS's indemnification will remain in effect for the lifetime of the Project(s). Following termination of the Grant Agreement, LPS shall remain solely responsible for any liability, costs or expenses related to its Project(s), including any request for repayment by DWR related to LPS's Project(s) and/or any other costs, fees and/or penalties, such as costs related to allegations of default under Section 14 of the Grant Agreement, which may be asserted against LACFCD by DWR related to the LPS's Project(s). LPS acknowledges that in no event shall LACFCD be responsible for any liability, costs, or expenses related to LPS's Project(s) or for the performance of work on, or the operation or maintenance of, the completed Project(s) as a result of the termination of the Grant Agreement or for any other reason.

Section (4) GENERAL INDEMNIFICATION

- (1) LPS shall indemnify, defend, and hold harmless LACFCD, the County of Los Angeles, Special Districts for which the Board of Supervisors for the County of Los Angeles and LACFCD acts as the governing body, elected and appointed officers, employees and agents from and against any and all liability, including, but not limited to, defense costs, demands, claims, allegations of default or breach of the Grant Agreement or this Agreement, actions, fees, costs and expenses (including attorney and expert witness fees) arising from or relating to: acts or omissions of the LPS related to its Project(s) and/or any acts or omissions of LACFCD made on behalf of or for the benefit of LPS pursuant to this Agreement, including, but not limited to, LACFCD's actions or activities in administering the grant funding and other LACFCD responsibilities set forth in Section (1)(1), but not including any acts or omissions of the LACFCD that involve the LACFCD's active negligence or willful misconduct. LPS liability arising from the active negligence or willful misconduct of LACFCD is excluded under this paragraph. This indemnity section shall remain in effect while the Grant Agreement, or any of its terms, is in effect and shall survive the termination, for any reason, of the Grant Agreement or this Agreement and shall remain in effect during the lifetime of the Project(s).
- (2) LACFCD shall indemnify, defend, and hold harmless LPS, its successors and assigns, officials, officers, employees, agents and those LPS agents serving as independent contractors in the role of LPS officials or officers from and against any and all liability, including, but not limited to, defense costs, demands, claims, allegations of default or breach of the Grant Agreement or this Agreement, actions, fees, costs and expenses arising from or relating to: LACFCD's active negligence or willful misconduct in its performance of LACFCD's RESPONSIBILITIES under this Agreement. This indemnity section shall remain in effect while the Grant Agreement, or any of its terms, is in effect and shall survive the termination, for any reason, of the Grant Agreement or this Agreement.
- (3) If, for whatever reason, DWR fails to fund any part of the grant commitment related to

the Project(s), LPS shall hold LACFCD harmless for that failure to fund and shall not seek any funding from LACFCD other than funds actually provided by DWR to LACFCD and specifically identified for LPS's Project(s). If, for whatever reason, DWR demands repayment of any part of the grant commitment related to the Project(s), LPS shall indemnify, defend, and hold LACFCD harmless for that repayment demand and shall not seek any funding from LACFCD in connection therewith.

- (4) LPS shall comply with the requirements set forth in CEQA and the CEQA Guidelines for its Project(s). LPS is ultimately and solely responsible for compliance with all applicable CEQA and NEPA requirements, including any mitigation measures required for the Project(s). LPS shall indemnify, defend, and hold harmless LACFCD, the County of Los Angeles, Special Districts for which the Board of Supervisors for County of Los Angeles and LACFCD acts as the governing body, elected and appointed officers, employees, and agents from and against any and all claims and/or actions related to the Project(s) that may be asserted by any third party or public agency alleging violations of CEQA or the CEQA Guidelines, NEPA and/or other Federal, State, and local environmental laws, rules, and regulations, guidelines, and requirements for the Project(s). This indemnity section shall remain in effect while the Grant Agreement, or any of its terms, is in effect and shall survive the termination, for any reason, of the Grant Agreement or this Agreement and shall remain in effect during the lifetime of the Project(s).

Section (5) CHILD SUPPORT LAWS

- (1) LACFCD's Policy on Child Support Laws

LPS acknowledges that LACFCD places a high priority on the enforcement of child support laws and the apprehension of child support evaders. LPS understands that it is LACFCD's policy to encourage all LACFCD contractors to voluntarily post LACFCD'S Los Angeles Most Wanted: Delinquent Parents List, in a prominent position at LPS's place of business.

- (2) Child Support Compliance Program

As required by LACFCD's Child Support Compliance Program (County Code Chapter 2.200), LPS shall maintain compliance with employment and wage reporting requirements as required by the Federal Social Security Act (42 USC Section 653) and California Unemployment Insurance Code Section 1088.5, and shall implement lawfully served Wage and Earnings Withholding Orders or District Attorney Notice of Wage Earnings Assignment for Child or Spousal Support, pursuant to Code of Civil Procedure, Section 706.031 and Family Code, Section 5246(b).

- (3) Termination for Noncompliance with Child Support Requirements

LPS shall maintain compliance with requirements of LACFCD's Child Support Compliance Program as certified in LPS's Child Support Compliance Program Certification and as set forth in this Agreement. Failure of LPS to maintain compliance

with these requirements will constitute a default under this Agreement. Failure to cure such a default within ninety (90) days of notice by LACFCD shall be grounds upon which LACFCD may give notice of termination and terminate this Agreement.

Section (6) NOTICE TO EMPLOYEES REGARDING THE FEDERAL EARNED INCOME CREDIT

- (1) LPS shall notify its employees, and shall require each subcontractor to notify its employees, that they may be eligible for the Federal Earned Income Credit under the Federal income tax laws. Such notice shall be provided in accordance with the requirements set forth in Internal Revenue Service Notice No. 1015.

Section (7) PROHIBITION AGAINST USE OF CHILD LABOR

- (1) LPS shall:
 - (a) Not knowingly sell or supply to LACFCD any products, goods, supplies or other personal property manufactured in violation of child labor standards set by the International Labor Organization through its 1973 Convention Concerning Minimum Age for Employment; and,
 - (b) Upon request by LACFCD, identify the country/countries of origin of any products, goods, supplies, or other personal property LPS supplies to LACFCD; and,
 - (c) Upon request by LACFCD, provide to LACFCD the manufacturer's certification of compliance with all international child labor conventions.
- (2) Should LPS discover that any products, goods, supplies, or other personal property sold or supplied by LPS to LACFCD are produced in violation of any international child labor conventions, LPS shall immediately provide an alternative, compliant source of supply.
- (3) Failure by LPS to comply with provisions of this section will be grounds for immediate suspension or termination of this Agreement.

Section (8) TERMINATION FOR IMPROPER CONSIDERATION

- (1) LACFCD may, by written notice to LPS, immediately terminate the right of LPS to proceed under this Agreement if it is found that consideration, in any form, was offered or given by LPS, either directly or through an intermediary, to any LACFCD officer, employee, or agent with the intent of securing this Agreement or securing favorable treatment with respect to the award, amendment, or extension of this Agreement or the making of any determinations with respect to LPS performance pursuant to this Agreement. In the event of such termination, LACFCD shall be entitled to pursue the same remedies against LPS as it could pursue in the event of default by LPS.

LPS shall immediately report any attempt by a LACFCD officer or employee to solicit such improper consideration. The report shall be made either to LACFCD manager charged with the supervision of the employee or to the Auditor-Controller's Employee Fraud Hotline at (800) 544-6861.

Among other items, such improper consideration may take the form of cash, discounts, services, the provision of travel, entertainment, or tangible gifts.

Section (9) NOTIFICATION

- (1) Any notices, bills, invoices, or reports relating to this Agreement, and any request, demand, statement or other communication required or permitted hereunder shall be in writing and
 - (a) shall be delivered to the representatives of the Parties at the addresses set forth below, except that any Party may change the address for notices by giving the other Party at least ten (10) days written notice of the new address:

LACFCD:
Ms. Terri M. Grant, Principal Engineer
Watershed Management Division
Los Angeles County Flood Control District
County of Los Angeles Department of Public Works
900 South Fremont Avenue
Alhambra, CA 91803-1331

LPS:
David Lippman, Director of Facilities & Operations
Las Virgenes Municipal Water District
4232 Las Virgenes Road
Calabasas, California 91302

- (b) or when LACFCD establishes a process to electronically upload some of the above stated information via the Web, the LPS shall submit the information accordingly as directed by LACFCD.

Section (10) MUTUAL COVENANTS

- (1) Governing Law: This Agreement shall be governed by, interpreted under, and construed and enforced in accordance with the laws of the State of California.
- (2) Amendment: No variation, modification, change, or amendment of this Agreement shall be binding upon any Party unless such variation, modification, change, or amendment is in writing and duly authorized and executed by both Parties. This Agreement shall not be amended or modified by oral agreements or understandings between the Parties or by any

acts or conduct of the Parties. Notwithstanding the above, the Parties agree that any amendment to the Grant Agreement (including any amendment to LPS's grant amount and corresponding change to the dollar amount of LACFCD's 2.5 percent administrative fee) shall become part of this Agreement upon the provision of written notice to the LPS without the necessity of further written agreement between the Parties absent the immediate provision of written objection by LPS to LACFCD.

- (3) Entire Agreement: This Agreement constitutes the entire Agreement between the Parties with respect to the subject matter of this Agreement and supersedes all prior and contemporaneous agreements and understandings.
- (4) No Third Party Beneficiary/Successors and Assigns: This Agreement is made and entered into for the sole protection and benefit of the Parties and their successors and assigns. No other person shall have any right of action based upon any provisions of this Agreement.
- (5) Waiver: No waiver of any breach or default by any Party shall constitute a waiver of any other breach or default, nor shall any such waiver constitute a continuing waiver. Failure of any Party to enforce at any time or from time to time, any provision of this Agreement shall not be construed as a waiver thereof. The remedies herein reserved shall be cumulative and additional to any other remedies in law or equity.
- (6) Covenant: All provisions of this AGREEMENT, whether covenants or conditions, on the part of LPS shall be deemed to be both covenants and conditions.
- (7) Interpretation: All Parties have been represented by counsel in the preparation and negotiation of this Agreement. Accordingly, this Agreement shall be construed according to its fair language and any ambiguities shall not be resolved against the drafting Party simply by virtue of having drafted the ambiguous provision.
- (8) Assignment: No Party shall assign this Agreement or any of such Party's interest, rights, or obligations, under this Agreement without the prior written consent of the other Party, which consent shall not be unreasonably withheld except that any Party may assign the Agreement, or any part thereof, to any successor governmental agency performing the functions of the assigning Party as its successor.
- (9) Manner of Execution: The Agreement may be executed simultaneously in counterpart, each of which shall be deemed an original, but together, shall constitute but one and the same instrument.
- (10) Relationship of Parties: The Parties are, and at all times shall remain as to each other, wholly independent entities. No Party to this Agreement shall have the power to incur any debt, obligation, or liability on behalf of any other Party unless expressly provided to the contrary by this Agreement. No employee, agent, or officer of a Party shall be deemed for any purpose whatsoever to be an agent, employee, or officer of another Party.

- (11) Successors: This Agreement shall be binding upon and shall insure to the benefit of the respective successors, heirs and assigns of each Party.

Section (11) NEGATION OF PARTNERSHIP

- (1) Nothing in this Agreement shall be construed to render LACFCD in any way or for any purpose a partner, joint venturer, or associate in any relationship with LPS, nor shall this Agreement be construed to authorize either Party to act as agent for the other Party unless expressly provided in this Agreement.

Section (12) SAVINGS CLAUSE

- (1) If any provision or provisions of this Agreement shall be determined by any court to be invalid, illegal or unenforceable to any extent, the remainder of the Agreement shall continue in full force and effect and this Agreement shall be construed as if the invalid, illegal or unenforceable provision(s) had never been contained in this Agreement.

Section (13) AUTHORITY TO ENTER INTO AGREEMENT

- (1) Each of the persons signing below on behalf of a Party represents and warrants that he or she is authorized to sign this Agreement on behalf of such Party.

Section (14) LACFCD LOBBYISTS

- (1) Each LACFCD lobbyist, as defined in the Los Angeles County Code Section 2.160.010, retained by LPS shall be in full compliance with Chapter 2.160 of the Los Angeles County Code. LPS's signature on the Agreement is its certification that it is in full compliance with Chapter 2.160. Failure on the part of any LACFCD lobbyist retained by LPS to fully comply with the County Lobbyist Ordinance shall constitute a material breach of this Agreement upon which LACFCD may immediately terminate or suspend this Agreement.

//

IN WITNESS WHEREOF, the Parties hereto have caused this Agreement to be executed by their respective officers, duly authorized by the LPS on _____, 2016, and by the LACFCD on _____, 2016

By _____ Date _____
GAIL FARBER
Chief Engineer

APPROVED AS TO FORM:

MARY C. WICKHAM
County Counsel

By _____ Date _____
Deputy

LAS VIRGENES MUNICIPAL WATER DISTRICT

ATTEST:

By _____ Date _____
DAVID W. PEDERSEN
GENERAL MANAGER

MEMORANDUM OF UNDERSTANDING [DRAFT]

THIS MEMORANDUM OF UNDERSTANDING (hereinafter referred to as "Agreement"), is made and entered into as of the date of the last Party signature set forth below between the LOS ANGELES COUNTY FLOOD CONTROL DISTRICT (hereinafter referred to as "LACFCD"), and **City of Calabasas** (hereinafter referred to as "Local Project Sponsor" or "LPS"). LACFCD and LPS are hereinafter referred to as "Parties" or, each individually, as "Party" for the following project(s): **Las Virgenes Creek Restoration Project – Phase II** (hereinafter referred to as "Project(s)"). The requested grant amount for the Project(s) is **\$645200.**

W I T N E S S E T H

WHEREAS, in November 2006, the voters of California enacted the Safe Drinking Water, Water Quality and Supply, Flood Control, River and Coastal Protection Bond Act, (hereinafter referred to as Proposition 84), adding provisions to the California Public Resources Code; and

WHEREAS, Proposition 84 amended the Public Resources Code to include Section 75026 et seq., which authorizes the Legislature to appropriate One Billion and 00/100 Dollars (\$1,000,000,000.00) for Integrated Regional Water Management (hereinafter referred to as "IRWM") projects (water resources-related projects that address water supply, water quality, and habitat/open space needs in a region); and

WHEREAS, the intent of the IRWM concept is to encourage integrated regional strategies for the management of water resources and to provide funding through competitive grants for projects that protect communities from drought, improve water reliability, protect and improve water quality, and improve local water security by reducing dependence on imported water; and

WHEREAS, the California Department of Water Resources (hereinafter referred to as "DWR") issued Proposition 84 IRWM Grant Program Guidelines for the 2015 IRWM Grant Program Guidelines and Implementation Grant Proposal Solicitation Package (hereinafter referred to as "Guidelines") in May 2015 to establish the process and criteria to solicit applications, evaluate proposals, and award Proposition 84 grants under the IRWM Grant Program; and

WHEREAS, eligible grant recipients under the Guidelines are public agencies defined as a City, County, City and County, District, joint powers authority, State agency or Department, or other political subdivision of the State, and nonprofit organizations defined as any California corporation organized under Sections 501(c)(3), 501(c)(4), or 501(c)(5) of the Federal Internal Revenue Code. Other entities that are part of the regional water management group responsible for applying for the grant may perform work funded by the grant; and

WHEREAS, under the Guidelines, IRWM Implementation grant proposals must be submitted by an IRWM Region that was accepted into DWR's IRWM Grant Program through the 2009 Region Acceptance Process and must: (1) include projects that are consistent with an adopted IRWM Plan (hereinafter referred to as "Plan"), (2) require project proponents to adopt the Plan or an update to the Plan, (3) describe specific implementation projects for which funding is being requested, and (4) identify matching funding; and

WHEREAS, the Plan for the Greater Los Angeles County Region (hereinafter referred to as "Region"), adopted on December 13, 2006, and updated and approved on August 27, 2014, will facilitate a regional approach to watershed management by establishing collaborative efforts across the watersheds within the Region; and

WHEREAS, the Region was accepted into DWR's IRWM Grant Program through the 2009 Region Acceptance Process in September 2009; and

WHEREAS, the Region's IRWM Group, which includes the Region's participating local entities and the LPSs identified in Exhibit F of the Grant Agreement, designated LACFCD as the regional entity to apply for grant funds on behalf of all proposed projects for the Region, through the IRWM process; and

WHEREAS, the implementation grant proposal for the Region included two (2) separate projects sponsored by the LACFCD and the following local entities, solely or jointly, (the projects are identified in Exhibit F to the Grant Agreement between DWR and LACFCD, which Grant Agreement, including all Exhibits thereto, is attached hereto and incorporated herein as Attachment A): Gateway Water Management Authority (4 separate projects); City of Malibu; Las Virgenes Municipal Water District; Mountains Restoration Trust; City of Calabasas; City of Inglewood; City of Torrance; City of Palo Verdes Estates; National Forest Foundation; The River Project; Glendale Water and Power; Crescenta Valley Water District; City of Monterey Park; and County of Los Angeles; and

WHEREAS, for IRWM projects funded under the implementation grant that will be implemented with the participation of more than one entity, it is the intention of the Parties that the LPS will be a single entity that is responsible for implementation of the Project(s) and which has the authority to enter into this Agreement on behalf of all entities participating in the Project(s); and

WHEREAS, LPS assumes all responsibilities and liabilities for the Project(s) under this Agreement (including the Grant Agreement responsibilities allocated to LPS under this Agreement). LPS will be the entity that invoices LACFCD, submits required information, including reports, notices and notifications, to LACFCD and provides any documentation and information requested or required under this Agreement or the Grant Agreement by LACFCD with respect to the implementation of the Project(s). In the event that the Project(s) will be implemented by more than one entity, LPS shall ensure that it has entered into appropriate written agreement(s) with each of the other Project-implementing entities to confirm the

authority of LPS to enter into this Agreement on their behalf, and shall ensure that each of the other Project-implementing entities agrees to defend, indemnify and hold harmless LACFCD to the same extent as the LPS provides to LACFCD in this AGREEMENT. Further, each entity participating in a Project acknowledges full responsibility for the implementation of the Project(s), including all responsibilities identified in this Agreement as well as the Grant Agreement and commits to the fulfillment of their respective obligations with respect to the Project(s). As to LACFCD, LPS remains solely responsible for all aspects of the Project(s); and

WHEREAS, DWR has indicated that it will award an implementation grant of up to Twenty-Seven Million, Seven Hundred and Forty-Two Thousand, Nine Hundred and Seventy-Five Dollars (\$27,742,975.00) to the LACFCD on behalf of the Region's LPSs; and

WHEREAS, DWR has indicated that it will enter into an agreement (hereinafter referred to as Grant Agreement) with LACFCD, for the administration of the implementation grant funds with respect to the nineteen (19) projects, including LPS's Project(s); and

WHEREAS, LPS desires that LACFCD execute the anticipated Grant Agreement with DWR and perform the role of Grantee therein on LPS's behalf so that LPS can receive and benefit from the Proposition 84 grant funds for its Project(s) in the amount to be identified in Exhibit B to the Grant Agreement; and

WHEREAS, LACFCD and LPS desire to enter into this Agreement to clarify their respective responsibilities with respect to the anticipated grant from DWR and the Parties' responsibilities pursuant to the Grant Agreement; specifically, the Parties intend that LACFCD's role will be to administer the grant funding and submit documentation required under the Grant Agreement to DWR on behalf of LPS, for which LACFCD will be reimbursed pursuant to this Agreement. LPS will be responsible for all other activities required under the Grant Agreement related to its Project(s), including, but not limited to construction, monitoring, Project management, operations and maintenance and legal compliance; and

WHEREAS, the LPS was awarded a project grant of **\$645200**. This amount reflects a 2.5 percent reduction in the LPS's requested grant amount to cover the LACFCD's costs for grant administration and oversight, which are reflected in Project 1 of Exhibit B of the Grant Agreement. The Parties intend by this Agreement to establish that LACFCD will seek reimbursement of its 2.5 percent administrative costs directly from DWR, and that the LPS will not pay or seek reimbursement for these costs; and

WHEREAS, the LPS previously agreed to pay LACFCD ~~approximately~~ **15292.75** per application for the cost of preparing and processing the LPS's grant application(s) for its project(s). LPS's grant budget includes a line item for this cost; and

WHEREAS the Parties acknowledge that LACFCD will not approve any aspect of the Project(s) or provide any resources related to implementation of the Project(s) outside of grant funding, if any, which is provided to LACFCD from DWR, specifically for the Project(s).

NOW, THEREFORE, LACFCD and LPS hereby agree as follows:

LACFCD'S RESPONSIBILITIES

Section (1) LACFCD AGREES TO, for as long as the Grant Agreement remains in effect:

- (1) Provide staff to oversee grant administration, manage grant funds and provide Project oversight as related to the grant.
- (2) Establish an independent account to manage the grant funds for each Project and provide routine updates to the LPS of balance and activities of each account.
- (3) Receive from LPS and submit to DWR the reports and information prepared and provided by LPS for each Project as requested by LACFCD and/or as required under the Grant Agreement.
- (4) LACFCD may execute amendments to the Grant Agreement on behalf of LPS, upon written request and approval by LPS and after LPS negotiates with DWR.
- (5) Process grant reimbursement requests submitted by LPS, including, submission of such requests to DWR and, only upon receipt of funds from DWR related to the invoices submitted, provide reimbursement to LPS within thirty (30) days of receipt by LACFCD of funds from DWR.
- (6) Submit grant reimbursement request(s) to DWR, for a total amount not to exceed **\$645200** to justify LACFCD's grant administrative costs, management, and project oversight efforts with respect to the IRWM grant, as authorized by DWR and pursuant to Section (2)(8).

LPS'S RESPONSIBILITIES

Section (2) LPS AGREES TO:

- (1) Retain sole and full responsibility for all aspects of LPS's Project(s) as identified in the Grant Agreement, including any approved amendments, including, but not limited to: planning, design, review and approval of plans, specifications, bid documents and construction documents, implementation; construction; management; Project oversight; monitoring; inspections; operation and maintenance; submission of Project reimbursement billing requests; provision of reports, notifications and notices; compliance with all legal requirements related to the Project(s) such as lead agency responsibilities, and all other applicable local, State and Federal statutes and regulations related to the Project(s) for the lifetime of the Project(s) notwithstanding any early termination of this Agreement.
- (2) Plan, design, construct, and continuously operate and maintain LPS's Project(s) pursuant to LPS's Work Plan as identified in Exhibit A to the Grant Agreement. LPS agrees to notify LACFCD and receive LACFCD's written approval as well as that of DWR in

advance of implementing any proposed changes to LPS's Project(s), including proposed future changes to the Work Plan.

- (3) Comply with all terms, provisions and commitments contained in the Grant Agreement, including all exhibits and attachments thereto, applicable to LPS or to LACFCD as Grantee or to representatives of Grantee under the Grant Agreement, whether or not herein specifically referenced, (with the exception of responsibilities identified in Section (1)(1) above which are solely responsibilities of LACFCD) for the lifetime of the Project(s). The Parties agree that responsibilities of LPS, Grantee, representatives of Grantee or activities for which LACFCD (as Grantee) and LPS may be listed as jointly responsible under the Grant Agreement, shall remain the sole responsibility of LPS, with the exception of activities herein listed as LACFCD'S RESPONSIBILITIES.
- (4) Comply with all applicable environmental requirements pertaining to the Project(s), including but not limited to the California Environmental Quality Act (CEQA), the State CEQA Guidelines and, if applicable, the National Environmental Policy Act (NEPA). Submit documents that satisfy the CEQA and NEPA process as well as any mitigation agreements, and environmental permits, including but not limited to DWR's Environmental Information Form. LACFCD is not responsible for any aspect of environmental compliance with respect to the Project(s), including any proposed future changes to LPS's Project(s), and no Project may be implemented absent LPS's compliance with CEQA and other environmental laws and regulations. Prior to submission of each invoice to LACFCD under this Agreement, LPS must submit written confirmation to LACFCD, in a format to be specified by LACFCD, that it has complied with all requirements of the Grant Agreement, including, but not limited to compliance with CEQA and, as applicable, NEPA for LPS's Project(s), including all work covered under the invoice, and shall provide appropriate evidence of its compliance. In addition, LPS agrees to submit written confirmation of CEQA and applicable NEPA compliance prior to implementing any future changes to its Project(s).
- (5) Demonstrate availability of funds to complete the Project by submitting the most recent three (3) years of audited financial statements and provide cost share funding match for the LPS's Project in the amount identified in Exhibit B of the Grant Agreement.
- (6) Ensure that any and all permits, licenses and approvals required for its Project(s) are obtained in a timely manner and maintained in effect as legally required.
- (7) Submit not more than one reimbursement request per month to LACFCD, in the format specified by LACFCD, executed by an authorized individual at LPS who is knowledgeable of the information and certifies and warrants the accuracy of the information contained in the reimbursement request.
- (8) Allow LACFCD to be reimbursed by DWR in an amount not to exceed **\$614,899.89**, representing 2.5 percent of LPS's requested grant amount for grant administrative costs, management, and project oversight efforts with respect to the IRWM, which has been subtracted from the LPS's requested grant amount, as reflected in Project 1 of Exhibit B

of the Grant Agreement. LPS thereby agrees that it will be reimbursed **\$645200** by LACFCD under this Agreement.

- (9) Prepare, provide and ensure accuracy of all deliverables, reports, documentation, notifications, notices and information related to the Project(s) as required under the Grant Agreement and/or requested by LACFCD to assist LACFCD and to enable LACFCD or LPS to provide information required under the Grant Agreement to DWR in a prompt and timely manner, in accordance with the provisions of the Grant Agreement.
- (10) Inform DWR and the LACFCD of any material changes related to the Project(s) as soon as possible including but not limited to, the progress of construction, Project budget(s), and Project benefits, through reporting process or other methods established by DWR and/or the LACFCD.
- (11) Repay the LACFCD any amount owed to DWR within 30 days of written notification, if for any reason DWR determines that LPS's Project(s) is no longer entitled to grant funds.
- (12) Provide regular and ongoing inspections of construction work in progress and be responsible to keep work under control. Authorize LACFCD to inspect the Project(s), at LACFCD's discretion, to review the progress of the Project(s).
- (13) Accept all liabilities and hold LACFCD legally and financially harmless if it is determined by court of law that LPS's allocation and use of the grant and matching funds is in violation of any applicable statutes, regulations, ordinances, guidelines, or requirements, including, but not limited to, grant requirements, and/or requirements governing contracting, and subcontracting, unless such violation(s) is due to LACFCD's active negligence or willful misconduct.
- (14) Accept sole responsibility for persons performing work related to the Project(s), including, but not limited to, employees, contractors, subcontractors, suppliers and providers of services.
- (15) Accept sole responsibility for any and all disputes arising out of contracts for implementation of the Project(s), including, but not limited to, payment disputes involving representatives of LPS, contractors and subcontractors. LPS acknowledges that LACFCD will not mediate or be involved with disputes between LPS and any other entity concerning responsibility for performance of work related to the Project(s).
- (16) Comply with all Basic Conditions, conditions for disbursement, Continuing Eligibility requirements, and Standard Conditions set forth in the Grant Agreement at all times.
- (17) Designate in writing a Project Manager with the full authority to act on behalf of LPS on any matter related to the Project(s), and advise LACFCD and DWR immediately in writing of any change in Project Manager.

Section (3) TERMINATION OF AGREEMENT

- (1) This Agreement shall remain in effect while the Grant Agreement or any provision of the Grant Agreement remains in effect. LPS's indemnification will remain in effect for the lifetime of the Project(s). Following termination of the Grant Agreement, LPS shall remain solely responsible for any liability, costs or expenses related to its Project(s), including any request for repayment by DWR related to LPS's Project(s) and/or any other costs, fees and/or penalties, such as costs related to allegations of default under Section 14 of the Grant Agreement, which may be asserted against LACFCD by DWR related to the LPS's Project(s). LPS acknowledges that in no event shall LACFCD be responsible for any liability, costs, or expenses related to LPS's Project(s) or for the performance of work on, or the operation or maintenance of, the completed Project(s) as a result of the termination of the Grant Agreement or for any other reason.

Section (4) GENERAL INDEMNIFICATION

- (1) LPS shall indemnify, defend, and hold harmless LACFCD, the County of Los Angeles, Special Districts for which the Board of Supervisors for the County of Los Angeles and LACFCD acts as the governing body, elected and appointed officers, employees and agents from and against any and all liability, including, but not limited to, defense costs, demands, claims, allegations of default or breach of the Grant Agreement or this Agreement, actions, fees, costs and expenses (including attorney and expert witness fees) arising from or relating to: acts or omissions of the LPS related to its Project(s) and/or any acts or omissions of LACFCD made on behalf of or for the benefit of LPS pursuant to this Agreement, including, but not limited to, LACFCD's actions or activities in administering the grant funding and other LACFCD responsibilities set forth in Section (1)(1), but not including any acts or omissions of the LACFCD that involve the LACFCD's active negligence or willful misconduct. LPS liability arising from the active negligence or willful misconduct of LACFCD is excluded under this paragraph. This indemnity section shall remain in effect while the Grant Agreement, or any of its terms, is in effect and shall survive the termination, for any reason, of the Grant Agreement or this Agreement and shall remain in effect during the lifetime of the Project(s).
- (2) LACFCD shall indemnify, defend, and hold harmless LPS, its successors and assigns, officials, officers, employees, agents and those LPS agents serving as independent contractors in the role of LPS officials or officers from and against any and all liability, including, but not limited to, defense costs, demands, claims, allegations of default or breach of the Grant Agreement or this Agreement, actions, fees, costs and expenses arising from or relating to: LACFCD's active negligence or willful misconduct in its performance of LACFCD's RESPONSIBILITIES under this Agreement. This indemnity section shall remain in effect while the Grant Agreement, or any of its terms, is in effect and shall survive the termination, for any reason, of the Grant Agreement or this Agreement.
- (3) If, for whatever reason, DWR fails to fund any part of the grant commitment related to the Project(s), LPS shall hold LACFCD harmless for that failure to fund and shall not seek any funding from LACFCD other than funds actually provided by DWR to

LACFCD and specifically identified for LPS's Project(s). If, for whatever reason, DWR demands repayment of any part of the grant commitment related to the Project(s), LPS shall indemnify, defend, and hold LACFCD harmless for that repayment demand and shall not seek any funding from LACFCD in connection therewith.

- (4) LPS shall comply with the requirements set forth in CEQA and the CEQA Guidelines for its Project(s). LPS is ultimately and solely responsible for compliance with all applicable CEQA and NEPA requirements, including any mitigation measures required for the Project(s). LPS shall indemnify, defend, and hold harmless LACFCD, the County of Los Angeles, Special Districts for which the Board of Supervisors for County of Los Angeles and LACFCD acts as the governing body, elected and appointed officers, employees, and agents from and against any and all claims and/or actions related to the Project(s) that may be asserted by any third party or public agency alleging violations of CEQA or the CEQA Guidelines, NEPA and/or other Federal, State, and local environmental laws, rules, and regulations, guidelines, and requirements for the Project(s). This indemnity section shall remain in effect while the Grant Agreement, or any of its terms, is in effect and shall survive the termination, for any reason, of the Grant Agreement or this Agreement and shall remain in effect during the lifetime of the Project(s).

Section (5) CHILD SUPPORT LAWS

- (1) LACFCD's Policy on Child Support Laws

LPS acknowledges that LACFCD places a high priority on the enforcement of child support laws and the apprehension of child support evaders. LPS understands that it is LACFCD's policy to encourage all LACFCD contractors to voluntarily post LACFCD'S Los Angeles Most Wanted: Delinquent Parents List, in a prominent position at LPS's place of business.

- (2) Child Support Compliance Program

As required by LACFCD's Child Support Compliance Program (County Code Chapter 2.200), LPS shall maintain compliance with employment and wage reporting requirements as required by the Federal Social Security Act (42 USC Section 653) and California Unemployment Insurance Code Section 1088.5, and shall implement lawfully served Wage and Earnings Withholding Orders or District Attorney Notice of Wage Earnings Assignment for Child or Spousal Support, pursuant to Code of Civil Procedure, Section 706.031 and Family Code, Section 5246(b).

- (3) Termination for Noncompliance with Child Support Requirements

LPS shall maintain compliance with requirements of LACFCD's Child Support Compliance Program as certified in LPS's Child Support Compliance Program Certification and as set forth in this Agreement. Failure of LPS to maintain compliance with these requirements will constitute a default under this Agreement. Failure to cure such a default within ninety (90) days of notice by LACFCD shall be grounds upon

which LACFCD may give notice of termination and terminate this Agreement.

Section (6) NOTICE TO EMPLOYEES REGARDING THE FEDERAL EARNED INCOME CREDIT

- (1) LPS shall notify its employees, and shall require each subcontractor to notify its employees, that they may be eligible for the Federal Earned Income Credit under the Federal income tax laws. Such notice shall be provided in accordance with the requirements set forth in Internal Revenue Service Notice No. 1015.

Section (7) PROHIBITION AGAINST USE OF CHILD LABOR

- (1) LPS shall:
 - (a) Not knowingly sell or supply to LACFCD any products, goods, supplies or other personal property manufactured in violation of child labor standards set by the International Labor Organization through its 1973 Convention Concerning Minimum Age for Employment; and,
 - (b) Upon request by LACFCD, identify the country/countries of origin of any products, goods, supplies, or other personal property LPS supplies to LACFCD; and,
 - (c) Upon request by LACFCD, provide to LACFCD the manufacturer's certification of compliance with all international child labor conventions.
- (2) Should LPS discover that any products, goods, supplies, or other personal property sold or supplied by LPS to LACFCD are produced in violation of any international child labor conventions, LPS shall immediately provide an alternative, compliant source of supply.
- (3) Failure by LPS to comply with provisions of this section will be grounds for immediate suspension or termination of this Agreement.

Section (8) TERMINATION FOR IMPROPER CONSIDERATION

- (1) LACFCD may, by written notice to LPS, immediately terminate the right of LPS to proceed under this Agreement if it is found that consideration, in any form, was offered or given by LPS, either directly or through an intermediary, to any LACFCD officer, employee, or agent with the intent of securing this Agreement or securing favorable treatment with respect to the award, amendment, or extension of this Agreement or the making of any determinations with respect to LPS performance pursuant to this Agreement. In the event of such termination, LACFCD shall be entitled to pursue the same remedies against LPS as it could pursue in the event of default by LPS.

LPS shall immediately report any attempt by a LACFCD officer or employee to solicit

such improper consideration. The report shall be made either to LACFCD manager charged with the supervision of the employee or to the Auditor-Controller's Employee Fraud Hotline at (800) 544-6861.

Among other items, such improper consideration may take the form of cash, discounts, services, the provision of travel, entertainment, or tangible gifts.

Section (9) NOTIFICATION

(1) Any notices, bills, invoices, or reports relating to this Agreement, and any request, demand, statement or other communication required or permitted hereunder shall be in writing and

(a) shall be delivered to the representatives of the Parties at the addresses set forth below, except that any Party may change the address for notices by giving the other Party at least ten (10) days written notice of the new address:

LACFCD:

Ms. Terri M. Grant, Principal Engineer
Watershed Management Division
Los Angeles County Flood Control District
County of Los Angeles Department of Public Works
900 South Fremont Avenue
Alhambra, CA 91803-1331

LPS:

Alex Farassati, Environmental Services Manager
City of Calabasas
100 Civic Center Way
Calabasas, California 91302

(b) or when LACFCD establishes a process to electronically upload some of the above stated information via the Web, the LPS shall submit the information accordingly as directed by LACFCD.

Section (10) MUTUAL COVENANTS

(1) Governing Law: This Agreement shall be governed by, interpreted under, and construed and enforced in accordance with the laws of the State of California.

(2) Amendment: No variation, modification, change, or amendment of this Agreement shall be binding upon any Party unless such variation, modification, change, or amendment is in writing and duly authorized and executed by both Parties. This Agreement shall not be amended or modified by oral agreements or understandings between the Parties or by any acts or conduct of the Parties. Notwithstanding the above, the Parties agree that any amendment to the Grant Agreement (including any amendment to LPS's grant amount

and corresponding change to the dollar amount of LACFCD's 2.5 percent administrative fee) shall become part of this Agreement upon the provision of written notice to the LPS without the necessity of further written agreement between the Parties absent the immediate provision of written objection by LPS to LACFCD.

- (3) Entire Agreement: This Agreement constitutes the entire Agreement between the Parties with respect to the subject matter of this Agreement and supersedes all prior and contemporaneous agreements and understandings.
- (4) No Third Party Beneficiary/Successors and Assigns: This Agreement is made and entered into for the sole protection and benefit of the Parties and their successors and assigns. No other person shall have any right of action based upon any provisions of this Agreement.
- (5) Waiver: No waiver of any breach or default by any Party shall constitute a waiver of any other breach or default, nor shall any such waiver constitute a continuing waiver. Failure of any Party to enforce at any time or from time to time, any provision of this Agreement shall not be construed as a waiver thereof. The remedies herein reserved shall be cumulative and additional to any other remedies in law or equity.
- (6) Covenant: All provisions of this AGREEMENT, whether covenants or conditions, on the part of LPS shall be deemed to be both covenants and conditions.
- (7) Interpretation: All Parties have been represented by counsel in the preparation and negotiation of this Agreement. Accordingly, this Agreement shall be construed according to its fair language and any ambiguities shall not be resolved against the drafting Party simply by virtue of having drafted the ambiguous provision.
- (8) Assignment: No Party shall assign this Agreement or any of such Party's interest, rights, or obligations, under this Agreement without the prior written consent of the other Party, which consent shall not be unreasonably withheld except that any Party may assign the Agreement, or any part thereof, to any successor governmental agency performing the functions of the assigning Party as its successor.
- (9) Manner of Execution: The Agreement may be executed simultaneously in counterpart, each of which shall be deemed an original, but together, shall constitute but one and the same instrument.
- (10) Relationship of Parties: The Parties are, and at all times shall remain as to each other, wholly independent entities. No Party to this Agreement shall have the power to incur any debt, obligation, or liability on behalf of any other Party unless expressly provided to the contrary by this Agreement. No employee, agent, or officer of a Party shall be deemed for any purpose whatsoever to be an agent, employee, or officer of another Party.
- (11) Successors: This Agreement shall be binding upon and shall inure to the benefit of the respective successors, heirs and assigns of each Party.

Section (11) NEGATION OF PARTNERSHIP

- (1) Nothing in this Agreement shall be construed to render LACFCD in any way or for any purpose a partner, joint venturer, or associate in any relationship with LPS, nor shall this Agreement be construed to authorize either Party to act as agent for the other Party unless expressly provided in this Agreement.

Section (12) SAVINGS CLAUSE

- (1) If any provision or provisions of this Agreement shall be determined by any court to be invalid, illegal or unenforceable to any extent, the remainder of the Agreement shall continue in full force and effect and this Agreement shall be construed as if the invalid, illegal or unenforceable provision(s) had never been contained in this Agreement.

Section (13) AUTHORITY TO ENTER INTO AGREEMENT

- (1) Each of the persons signing below on behalf of a Party represents and warrants that he or she is authorized to sign this Agreement on behalf of such Party.

Section (14) LACFCD LOBBYISTS

- (1) Each LACFCD lobbyist, as defined in the Los Angeles County Code Section 2.160.010, retained by LPS shall be in full compliance with Chapter 2.160 of the Los Angeles County Code. LPS's signature on the Agreement is its certification that it is in full compliance with Chapter 2.160. Failure on the part of any LACFCD lobbyist retained by LPS to fully comply with the County Lobbyist Ordinance shall constitute a material breach of this Agreement upon which LACFCD may immediately terminate or suspend this Agreement.

//

IN WITNESS WHEREOF, the Parties hereto have caused this Agreement to be executed by their respective officers, duly authorized by the LPS on _____, 2016, and by the LACFCD on _____, 2016

By _____
GAIL FARBER
Chief Engineer
Date _____

APPROVED AS TO FORM:

MARY C. WICKHAM
County Counsel

By _____
Deputy
Date _____

[LPS NAME]

ATTEST:

By _____
SCOTT H. HOWARD
SCOTT H. HOWARD
Date _____

APPROVED AS TO FORM:
SCOTT H. HOWARD

By _____
Date _____



April 26, 2016 LVMWD Regular Board Meeting

TO: Board of Directors

FROM: Facilities & Operations

Subject : Replacement of Construction Service Truck: Purchase Orders

SUMMARY:

The Construction Section of the Facilities and Operations Department utilizes a large, specialized service truck to carry the heavy tools and equipment required to maintain the District's underground infrastructure. At 25 years old, the current truck, a 1991 Ford F-700 with a custom service body, has reached the end of its useful life and requires replacement. Staff proposes to replace the vehicle with a Freightliner cab and chassis outfitted with a utility body and compressor, both separately purchased.

RECOMMENDATION(S):

Authorize the General Manager to issue purchase orders to Velocity Truck Centers of Oxnard/Los Angeles Truck Centers, LLC, in the amount of \$89,979.48, for a Freightliner M2 106 Cab and Chassis, and Skaug Truck Body Works of San Fernando, in the amount of \$41,724.98, for the purchase and installation of a custom-matched utility body; and declare Vehicle No. 136 as surplus equipment for salvage.

FISCAL IMPACT:

Yes

ITEM BUDGETED:

Yes

FINANCIAL IMPACT:

The total cost of the vehicle, including the utility body and compressor, is \$149,408.42. Sufficient funds are available in the adopted Fiscal Year 2015-16 Budget under CIP No.10599 for the replacement vehicle.

DISCUSSION:

The goal for purchasing the new service truck is to ensure proper fitment of the tools and equipment needed for the construction crew. Five different utility body builders were provided specifications and invited to inspect the existing service truck. The Freightliner cab and chassis were chosen to ensure driver safety, maneuverability and to meet the crew's needs. Members of the crew test drove Freightliner and International trucks. Following the test drives, the Freightliner was determined to be the preferred truck due to its very good field of vision for safety and its drive-ability in the hills of the District's service area.

A shorter wheelbase allows the Freightliner chassis better access to many of the District's difficult to reach water mains than the International chassis and drivetrain. Freightliner also offers the latest Cummings engine, which includes more horsepower and torque than the International truck. At a gross vehicle weight rating of 33,000 pounds, the truck is configured for the many steep inclines within the District's service area. Terex Services will add an under-deck mounted PTO-driven air compressor to fit the shorter wheelbase.

The following quotes were received for the new service truck:

- Velocity Truck Centers of Oxnard/Los Angeles Truck Centers, LLC - \$82,457 plus tax and fees
- Los Angeles Freightliner of Fontana - \$84,957 plus tax and fees
- Freightliner of San Diego - \$87,057 plus tax and fees

Velocity Truck Center of Oxnard/Los Angeles Truck Centers, LLC was the low bidder for the Freightliner cab and chassis.

The following quotes were received for the new service truck utility body:

- Skaug Truck Body Works - \$41,724.98 custom-matched utility body
- Specialty Equipment Company - \$63,431.00 custom-matched utility body
- Scelzi Enterprises - \$42,332.30 standard utility body (non-responsive to specifications)
- Crane Works of San Diego - Declined to bid
- CTEC Truck Bodies - Responded to inquiry but no bid submitted

Skaug Truck Body Works of San Fernando was the low bidder for the utility body.

The following quotes were received for the new compressor and installation:

- Terex Services - \$17,703.96
- California Truck Equipment Company - \$23,087.29
- Specialty Equipment Company - No bid provided
- Skaug Truck Body Works - Installation only
- Crane Works - No bid provided

Terex Services of Fontana was the low bidder to provide and install an underdeck compressor for the new service truck. The General Manager proposes to issue a purchase order to Terex Services of Fontana, in the amount of \$17,703.96, for the compressor as the amount is within his approval authority.

GOALS:

Construct, Manage and Maintain All Facilities and Provide Services to Assure System Reliability and Environmental Compatibility

Prepared by: Darrell Johnson, Facilities Maintenance Supervisor

ATTACHMENTS:

Photos of Existing Construction Service Truck
Proposed Freightliner Cab and Chassis

Vehicle #136





TRUCKS DEALERS PARTS & SERVICE FINANCING WHY FREIGHTLINER? Q



Newsletter Sign Up

Find Dealer

Request Quote

Service trucks you can count on.

Freightliner is known for combining dependability and efficiency – and our service trucks are no different. We produce reliable vehicles that positively impact the bottom line, making Freightliner a leading choice when evaluating service trucks for sale. When you invest in a truck from Freightliner, you invest in your business.



M2 106 >

When reliability, maneuverability and visibility are top priorities, the Freightliner M2 106 is the answer. Our trucks are reliable for the long haul, which helps our customers remain profitable. Excellent efficiency, from fuel economy to cost of operation, makes this service truck a top choice for your bottom line.

106" BBC 56,000 GVW 200 to 350 HP
520 to 1,000 lb/ft.

Request Quote >

Find Dealer >



April 26, 2016 LVMWD Regular Board Meeting

TO: Board of Directors

FROM: Facilities & Operations

**Subject : Lost Hills Interchange 10-inch Recycled Water Main Relocation Project:
Change Order No. 1**

The Las Virgenes-Triunfo Joint Powers Authority (JPA) approved funding for this matter in the JPA Budget. This recommendation is before the LVMWD Board for action, as Administering Agent, as authorized by the JPA Agreement.

SUMMARY:

On March 2, 2015, the JPA Board authorized the Administering Agent/General Manager to proceed with the Lost Hills Interchange 10-inch Recycled Water Main Relocation Project, in the amount of \$496,742, as part of the City of Calabasas' Interchange Project. During the construction submittal process, the City's construction team determined the pipeline casing support assemblies required redesign to provide sufficient clearance between the top of the casing and the bottom of the bridge deck to accommodate space needed for deck forms and casing welding. The Contractor provided a quotation, in the amount of \$121,918.72, for the increased cost associated with 64 redesigned casing support assemblies. Staff reviewed the supporting information and determined the cost is commensurate with the additional work required for fabrication of the assemblies.

RECOMMENDATION(S):

Authorize the General Manager to approve Change Order No. 1, in the amount of \$121,918.72, for the Lost Hills Interchange 10-inch Recycled Water Main Relocation Project.

FISCAL IMPACT:

Yes

ITEM BUDGETED:

Yes

FINANCIAL IMPACT:

Sufficient funds are available in the adopted Fiscal Year 2015-16 JPA Budget for this work. No additional appropriation is required.

DISCUSSION:

The original design for the pipeline casing support assemblies was based on a similar design used for the Reyes Adobe Bridge. The construction plans showed approximately 10 inches of clearance between the top of the casing and the bottom of the bridge deck. However, due to the low profile girder used for the Lost Hills Bridge and a scaling error on the plans, a clearance of only 2 to 3 inches was evident when the construction shop drawings were prepared for the casing support assemblies. The narrow clearance is insufficient for the Contractor to place the deck formwork and weld the casing joints. The City's Design Engineer redesigned the casing support assemblies to provide 10 inches of clearance as shown on the original plans.

The original three-piece casing support assemblies were bolted (no welding) and cost \$1,995.00/each based on the itemized bid pricing. The redesigned casing assemblies consist of six pieces and require welding. The Contractor provided a quotation reflecting an additional \$1,904.98/each after including a 15% markup allowed by the contract documents. As a result, the total cost of Change Order No. 1 is \$121,918.72, for a total of 64 redesigned casing support assemblies. Staff reviewed the supporting information and determined the cost is commensurate with the additional work required for fabrication of the assemblies.

Attached for reference are the quotation from the Contractor and copies of the applicable plans and shop drawings showing the pipeline casing support assemblies.

GOALS:

Construct, Manage and Maintain All Facilities and Provide Services to Assure System Reliability and Environmental Compatibility

Relocation of the 10-inch recycled water main is necessary due to the replacement of the Lost Hills Interchange bridge by the City of Calabasas.

Prepared by: Eric Schlageter, P.E., Senior Engineer

ATTACHMENTS:

- Quotation for Redesigned Support Assemblies
- Original Design Plans
- Shop Drawing - Original Design
- Shop Drawing - Revised Design

April 07, 2016

Job No: EA 07-242304

Spec. No.: 14-15-05

Memo No: 1

LVMWD

Attn: John Zhao, PE, Principal Engineer
4232 Las Virgenes Road
Calabasas, CA 91302
Phone: 818-251-2100

**Reference: US ROUTE 101 LOST HILLS RD INTERCHANGE PROJECT
CITY OF CALABASAS**

Subject: Revised Utility Support Cost

Dear Mr. Zhao,

This memo is to inform you of the impact of the revised utility supports and proposed additional cost for their fabrication as part of the Lost Hills Interchange Project, Schedule B (Las Virgenes Municipal Water District Lost Hills Bridge Replacement - Water Line Relocation).

Project contractor provided shop drawings for original utility supports stating that the distance between the top of the casing and the bottom of the bridge deck does not allow them to complete this work as planned. Cross section on the original plans, when scaled, shows about 10 inches of space between the top of the casing and the bottom of the bridge deck and the contractor thought that they have that much space for construction. Once the original design was drawn to scale for shop drawings submittal, this gap was only about 2-3 inches. A meeting with the designer, utility owner, city and the CM team has been conducted to evaluate the issue brought up by the contractor. Based on examination of the facts and the discussions everybody agreed that the original design is not constructible. Precast bridge girders exhibit large camber deflection swings between installation and loading them with the bridge deck in the middle of each span. Bridge deck forms would not be accommodated by the original design or the necessary field welding of the water line casing was possible. As a result, the designer worked on revising the supports to provide additional space.

Final revised design lowered the casings support to the original 10 inches to allow for bridge deck deflections during construction stages as well as for field welding of the casings. The revised design includes additional steel material, labor and processing (cutting, drilling, welding and galvanizing). Estimated weight of each support is about 50% increase, compared to the original design. Sales tax and contractor's markup brought the final added cost for this change to **\$1,904.98** per unit, or total of **\$121,918.40** for 64 supports as increase for Schedule B Bid Item No. 22 "Cross Member Supports with Nelson Studs and Connection Plates".

CM reviewed the proposed additional cost and finds it reasonable and recommends approval of the contractor's additional compensation and processing of the change order for revisions. This additional cost will be processed as a change order paid as an adjustment of compensation for agreed unit cost of **\$1,904.98/EA** for a total cost increase of **\$121,918.40** for 64 supports as

shown in the bid schedule. Please provide your written concurrence and approval for processing of this change order.

If you have any question or need additional information please call me at (626) 712-6532.

Sincerely,

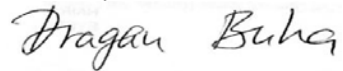

Dragan Buha,
Resident Engineer

PARSONS

Attachment: SPC Cost Proposal
DB

File

cc: Tatiana Holden - City of Calabasas

Alan Davis – Caltrans Oversight

GENERAL CONTRACTOR
 LICENSE NO. 116307 A C12
 FAX: 818.362.9300

SECURITY PAVING COMPANY, INC.

13170 TELFAIR AVENUE
 SYLMAR, CA 91243
 TEL. 818.362.9200

April 6, 2016

Letter 334-07.1

Parsons
 100 West Walnut Street
 Pasadena, CA 91124

Attention: Dragan Buha, Resident Engineer

Reference: Route 101/Lost Hills Interchange Project
 City of Calabasas

Re: REVISED QUOTE – Revised Utility Supports

Dear Mr. Buha,

Per your request we are providing the following quote for revisions made to the bridge utility supports. The price was derived from revised plans dated 12/14/15 and the Engineers response to RFI #43. Due to these design changes there is an increase in the cost of material and fabrication. These changes constitute a change in the character of work, therefore, we cannot accept compensation at contact unit prices. We have included copies of the original and new quotes for your use. The revised price for utility supports is as follows:

Item	Description	Qty (ea.)	Original Unit Price	New Unit Price	Diff.	Diff. w/ 15% MU	Total Cost Diff.
Schedule A							
201	Line A - Modified 18" Dia. Casing Support Assm. (telephone line)	32	1995.00	3651.50	1,656.50	1,904.98	\$ 60,959.20
Schedule B							
22	Cross Member Supports with Nelson Studs and Conneciton Plates	32	1995.00	3651.50	1,656.50	1,904.98	\$ 60,959.20
22	Cross Member Supports with Nelson Studs and Conneciton Plates	32	1995.00	3651.50	1,656.50	1,904.98	<u>\$ 60,959.20</u>
TOTAL PRICE INCREASE							\$ 182,877.60

GENERAL CONTRACTOR
LICENSE NO. 116307 A C12
FAX: 818.362.9300

**SECURITY
PAVING**

COMPANY, INC.

13170 TELFAIR AVENUE
SYLMAR, CA 91243
TEL. 818.362.9200

Price includes all applicable sales tax and shipping.

If you have any questions I can be reached at 818-612-1859

Respectfully,



Pete Wilson
Project Manager

LBIW

Machinists - Foundry - Fabricators
2020 WEST 14TH STREET, LONG BEACH, CA 90813
PHONE: (562) 432-3451 FAX: (562) 435-5929

Bids Received by: **SECURITY PAVING**

Attention: PETE WILSON

Bid Date: 04/05/16

*****SENT VIA EMAIL*****

bbrady@lbiw.com

We are pleased to provide you with a quote for the following miscellaneous metals for the construction of:

Project: U.S. ROUTE 101 LOST HILLS ROAD INTERCHANGE (REPLACE); CDOT 07-242304; RFI 043

Location: SYLMAR, CA QUOTATION ID: FQT 04.05.16 BB SECURITY PAVING RFI 043

ITEM	QTY	U/M	DESCRIPTION OF ITEMS TO BE FURNISHED	UNIT PRICE	U/M	TOTAL
<i>ORIGINAL QUOTATION DATED 02-27-2015 FOR SCHEDULES A AND B</i>						
BID ITEM 201 SCHEDULE A	30	EA	UTILITY SUPPORT ASSEMBLY FOR 18 INCH DIAMETER CASING *REFERENCES: DESIGN DRAWING SHEETS 421/425/441			
BID ITEM 13 SCHEDULE B	30	EA	UTILITY SUPPORT ASSEMBLY FOR 18 INCH DIAMETER CASING FOR 10 INCH DIAMETER WATERLINE *REFERENCES: DESIGN DRAWING SHEETS 421/425/441			
TOTAL	60	EA	UTILITY SUPPORTS: SCHEDULES A AND B	\$1,995.00	EA	\$119,700.00
	1	LS	RAW MATERIALS (UTILITY SUPPORT COMPONENTS)	21.46%	LS	
	1	LS	GALVANIZING (SAND BLASTING AND COATING)	6.84%	LS	
	1	LS	SHOP LABOR (CUTTING, WELDING, GRINDING, CLEAN-UP)	35.87%	LS	
	1	LS	SHOP SUPERVISION/CONTINUOUS CWI INSPECTIONS	2.30%	LS	
	1	LS	FASTENERS/BUY OUTS/SPECIAL HANDLING/TRUCKING	3.01%	LS	
	1	LS	SUBCONTRACT WORK (E.G., MATERIALS CUT-TO-SIZE)	3.91%	LS	
	1	LS	SHOP DRAWINGS FOR SUBMITTAL	2.37%	LS	
	1	LS	SHOP DRAWINGS FOR FABRICATION	2.25%	LS	
	1	LS	G&A AND PROFIT	21.98%	LS	
TOTALS				100.00%		\$119,700.00
ADD 9% SALES TAX				9.00%	LS	\$10,773.00
DELIVERY IS INCLUDED				\$0.00		\$130,473.00

AMENDED QUOTATION DATED 01-21-2016 FOR SCHEDULES A AND B RELATING TO ENGINEERING DESIGN CHANGES DIRECTED BY OWNER'S REPRESENTATIVE

BID ITEM 201 SCHEDULE A	30	EA	MODIFIED UTILITY SUPPORT ASSEMBLY FOR 18 INCH DIAMETER CASING *REFERENCES: DESIGN DRAWING SHEETS 421/425/441			
BID ITEM 13 SCHEDULE B	30	EA	MODIFIED UTILITY SUPPORT ASSEMBLY FOR 18 INCH DIAMETER CASING FOR 10 INCH DIAMETER WATERLINE *REFERENCES: DESIGN DRAWING SHEETS 421/425/441			
TOTAL	60	EA	MODIFIED UTILITY SUPPORTS: SCHEDULES A AND B	\$3,350.00	EA	\$201,000.00
	1	LS	RAW MATERIALS (UTILITY SUPPORT COMPONENTS)	20.32%	LS	
	1	LS	GALVANIZING (SAND BLASTING AND COATING)	6.44%	LS	
	1	LS	SHOP LABOR (CUTTING, WELDING, GRINDING, CLEAN-UP)	32.90%	LS	
	1	LS	SHOP SUPERVISION/CONTINUOUS CWI INSPECTIONS	2.55%	LS	
	1	LS	FASTENERS/BUY OUTS/SPECIAL HANDLING/TRUCKING	3.85%	LS	
	1	LS	SUBCONTRACT WORK (E.G., MATERIALS CUT-TO-SIZE)	4.75%	LS	
	1	LS	SHOP DRAWINGS FOR SUBMITTAL	2.66%	LS	
	1	LS	SHOP DRAWINGS FOR FABRICATION	2.76%	LS	
	1	LS	G&A AND PROFIT	23.78%	LS	
TOTALS				100.00%		\$201,000.00
ADD 9% SALES TAX				9.00%	LS	\$18,090.00
DELIVERY IS INCLUDED				\$0.00		\$219,090.00

DIST	COUNTY	ROUTE	TOTAL PROJECT SHEETS	SHEET NO.
07	LA	101	31-6/22-3	418

REGISTERED CIVIL ENGINEER
 DATE 12/09/14
 CITY OF CALIFORNIA
 T.Y. LIN INTERNATIONAL
 3550 Vine Street, Suite 120
 Livermore, CA 94551

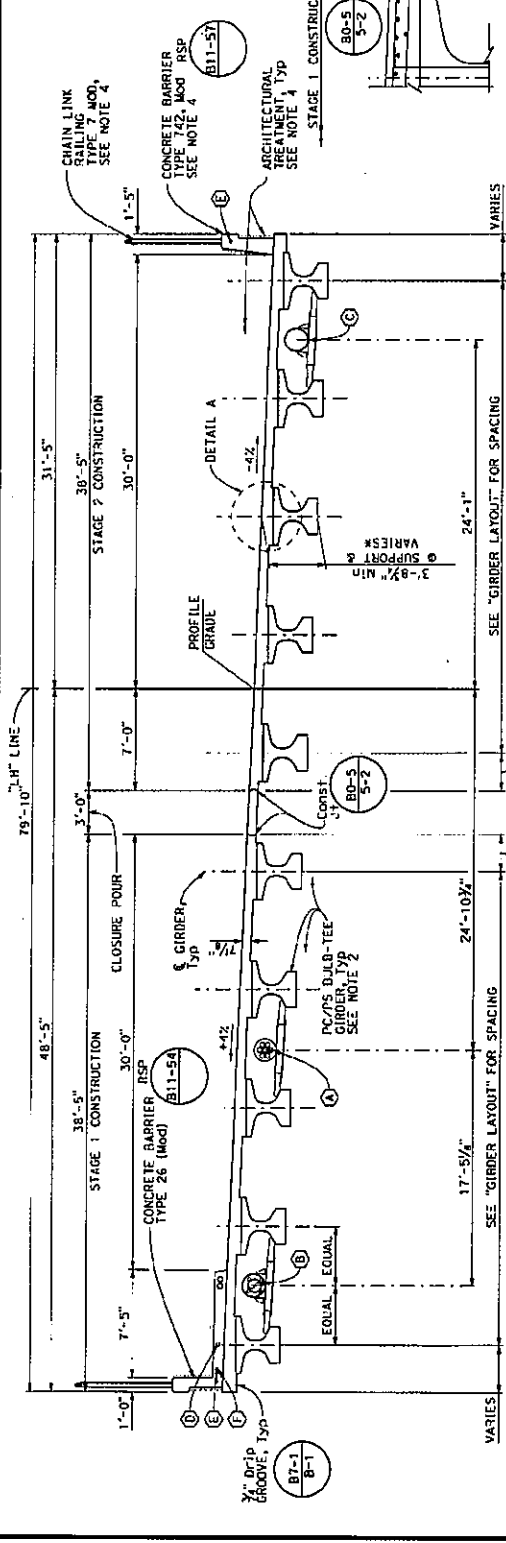

CLOSURE POUR
 3/4" x 1'-0"

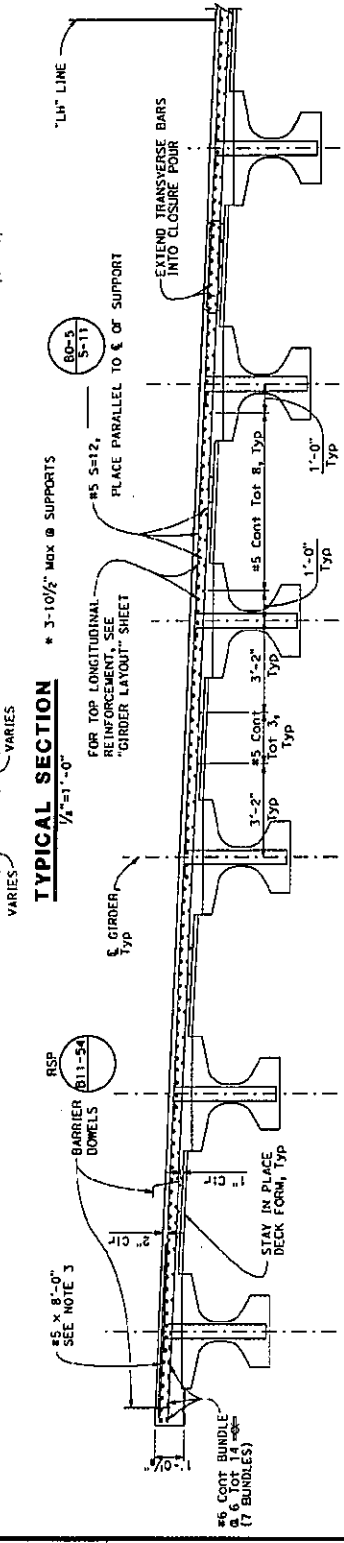

PART TYPICAL SECTION
 7/8" x 17'-0"

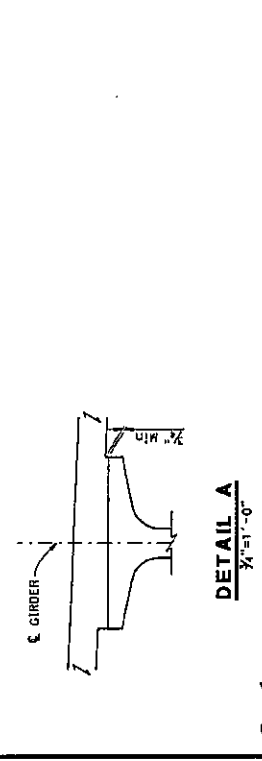

NOTES:

1. For Bolt-Tee spacing, see "GIRDER LAYOUT" sheet.
2. For Girder details, see "GIRDER DETAILS NO. 1" and "GIRDER DETAILS NO. 2" sheets.
3. Buckle with alternating top transverse bars. Limits of buckles shall be 5'-0" from each end of outside barrier rail.
4. For Chain Link Railing Type 7 Mod, and Architectural Treatment, see "ARCHITECTURAL DETAILS NO. 1 & NO. 2" sheets.

UTILITIES:

- ① - 18" Dia Casing and 7-4" Dia telephone conduits
- ② - 18" Dia casing and 10" waterline
- ③ - 18" Dia casing for future 10" waterline
- ④ - 3" Interconnection conduit
- ⑤ - 2" Bridge mounted sign lighting conduit
- ⑥ - 2" Ramp metering conduit

PREPARED FOR THE STATE OF CALIFORNIA DEPARTMENT OF TRANSPORTATION		DESIGN NO. 23-3086	PROJECT NO. 31-91	CONTRACT NO. 31-24234	SHEET NO. 17
DESIGNER Robert Barton	CHECKER Robert Barton	PROJECT ENGINEER Bob Giffith	PROJECT NO. 31-91	CONTRACT NO. 31-24234	SHEET NO. 17
QUANTITIES Scott Firas	CHECKED Robert Barton	PROJECT ENGINEER Bob Giffith	PROJECT NO. 31-91	CONTRACT NO. 31-24234	SHEET NO. 17

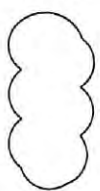
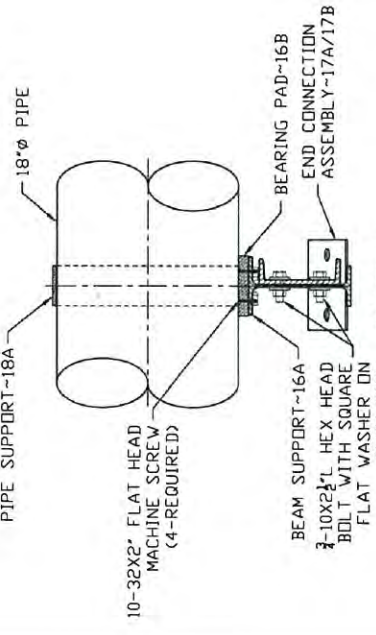
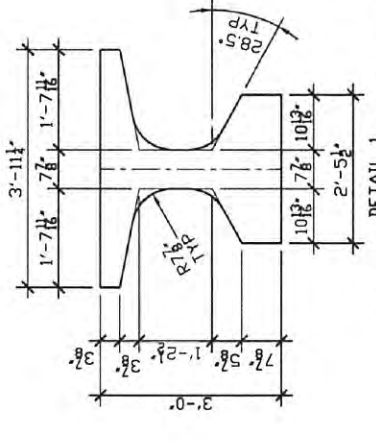
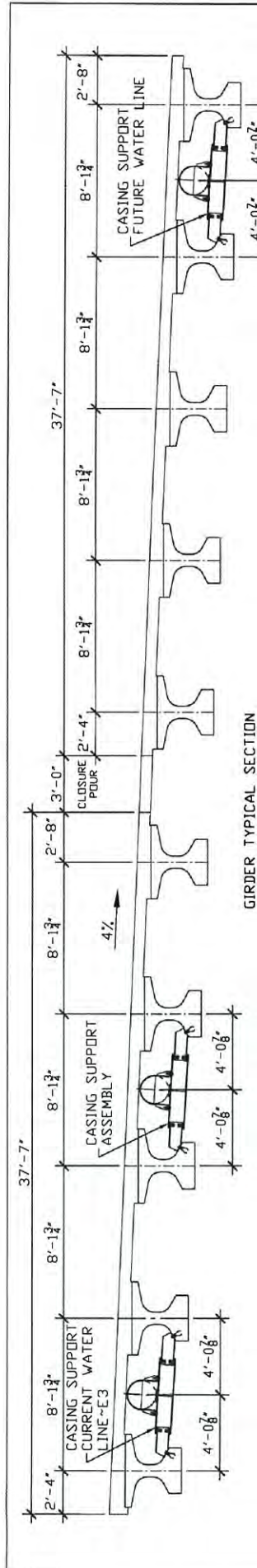

FOR APPROVAL
DATE JUN 18, 2015
LBIW/CA

COMPROMENTIAL: This drawing is the property of LBIW, inc. and embodies confidential information; registered marks, and other proprietary information of LBIW, inc. The unauthorized use of this drawing for any purpose other than that intended for this document, without the expressed written approval by LBIW, inc. is prohibited. All rights reserved.

REV. NO.	REVISION LOG	DATE

SHOP FINISH	HOT DIP GALVANIZED PER ASTM A123 AFTER FABRICATION	
BUY AMERICA	YES	INSPECTION NO
LOOSE OR NTR		
MELTED AND REWORKED IN THE USA	YES	WORK ORDER NO. OR B PERMIT NO.
CAL TRANS CONTRACT NO.		
BID ITEM NO.	13	

LBIW, Inc.
2020 West 14th Street
Long Beach, CA 90813

PHONE: (562) 432-5451
FAX: (562) 435-5929
E-MAIL: lbiw@lbiw.com

CONTRACTOR: SECURITY PAVING
PROJECT: LOST HILLS ROAD INTERCHANGE-CITY OF CALABASAS
BID ITEM: CASING SUPPORT ASSEMBLY
SCHEDULE B ITEM 13 CURRENT WATER LINE
DRAWN BY: GRA DATE: 06/01/15 LBIW ORDER NO. SHEET NO.
CHECKED BY: DATE: 19211 E3

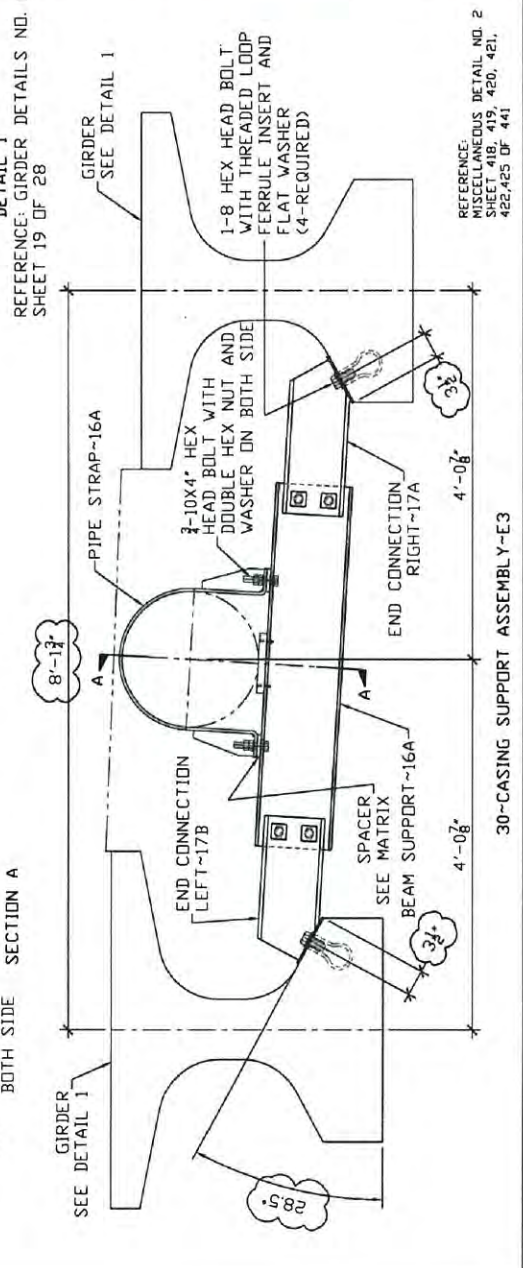

REFERENCE:
MISCELLANEOUS DETAIL NO. 2
SHEET 418, 419, 420, 421,
422, 425 OF 441

DIST	COUNTY	ROUTE	POST MILE PROJECT	TOTAL SHEETS	SHEET NO.
07	LA	101	31.6/32.3	425	441

REGISTERED CIVIL ENGINEER	DATE	12/09/14
PROFESSIONAL ENGINEER David Griffin No. 26875 Exp. 3/31/2016 CIVIL STATE OF CALIFORNIA		
PLANS APPROVAL DATE David Griffin No. 26875 Exp. 3/31/2016 CIVIL STATE OF CALIFORNIA		
CITY OF CALIFORNIA 100 Civic Center Way Colton, Ca 91302 T. Y. LIN INTERNATIONAL 3450 Vine Street, Suite 120 Riverside, Ca 92507		

- UTILITIES:**
- A - 18" Dia Casing and 7-4" Dia Telephone conduits, see note 1
 - B - 18" Dia casing and 10" waterline, see note 2
 - C - 18" Dia casing for future 10" waterline, see note 2
- NOTES:**
1. Casing shall extend to 5' beyond the end of the approach slab.
 2. For casing and carrier pipe details, see LYMMD Plans.
 3. Galvanize steel parts of support assembly in accordance with the Specifications.
 4. Tighten bolts after deck slab concrete placement is complete.

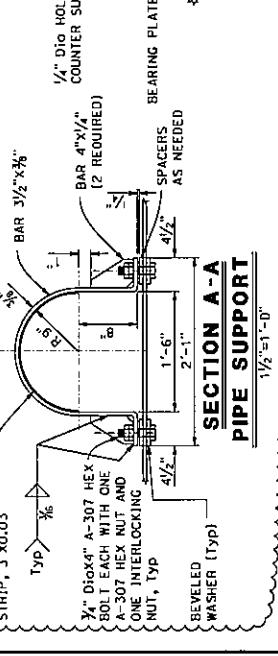
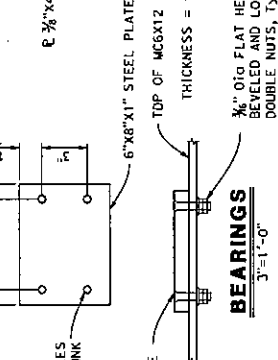
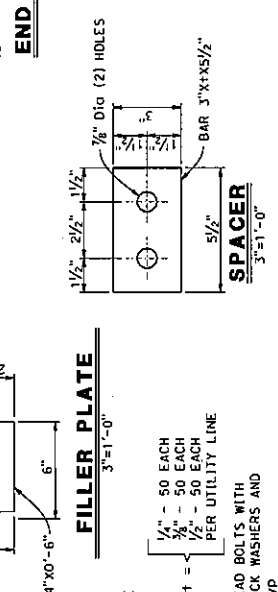
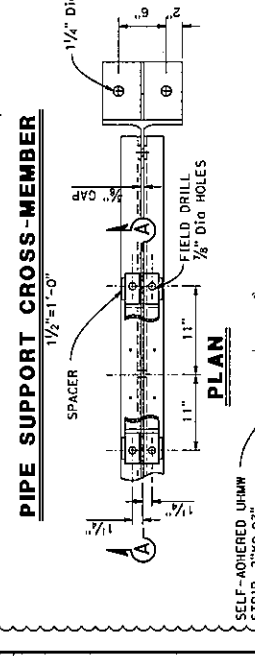
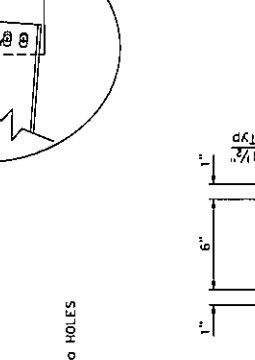
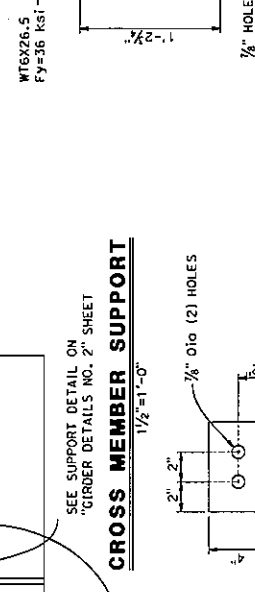
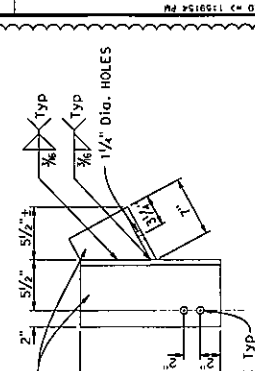
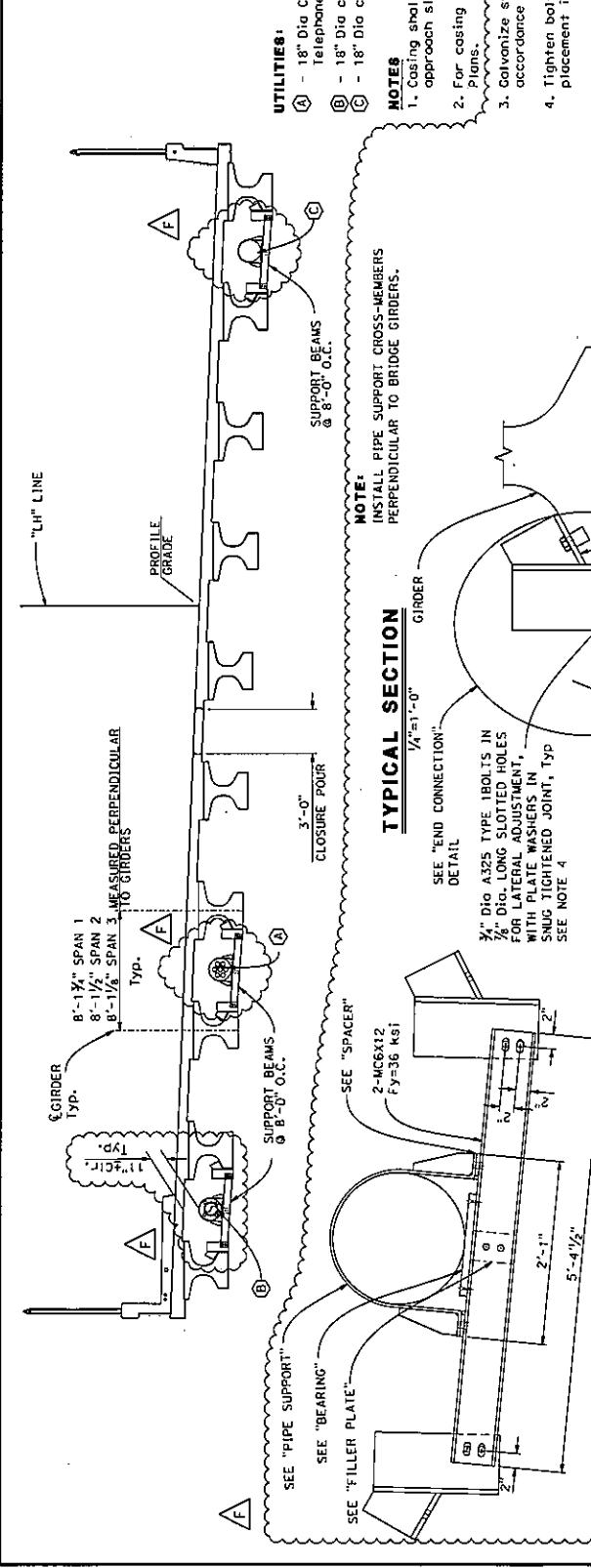

PREPARED FOR THE STATE OF CALIFORNIA DEPARTMENT OF TRANSPORTATION

PROJECT NUMBER & PHASE: 0700000419
 CONTRACT NO.: 07-212304
 UNIT: 07
 FILE #: 53-1130-9-00003-4002.dgn

DESIGNER: Robert Barton
CHECKER: Oscar Colcol
QUANTITIES: Sabine Pinos

DESIGN OVERSIGHT: William Rodriguez
CHECKER: Oscar Colcol
QUANTITIES: Sabine Pinos

UTILTY SUPPORT REVISIONS - 12/14/15

REVISION NO. 1
 REVISION DATE 12/14/15
 REVISION DESCRIPTION



April 26, 2016 LVMWD Regular Board Meeting

TO: Board of Directors

FROM: Resource Conservation & Public Outreach

Subject : Proposed Policy for Temporary Meter Service

SUMMARY:

On March 8, 2016, Mr. Don Schmitz and Ms. Gabrielle Harris addressed the Board to express a concern that the District was not issuing temporary meters to residents whose private wells had gone dry due to the drought. Director Caspary requested that staff evaluate the issue and propose a policy for the Board's consideration. Staff proposes the Board approve the following broad policy framework for temporary meter service, which would be implemented by staff and allow for sufficient flexibility to address the varied needs of customers:

"All District residents are eligible to receive water service. To safeguard public health and safety, water service may be provided through a temporary meter for existing dwellings not currently served by the water system. Temporary meter service may also be provided to support construction, environmental purposes, municipal services and community activities. Recycled water must be used, where available and as allowed by regulations, to the greatest extent possible. Water service through temporary meters will be provided in accordance with the Las Virgenes Municipal Water District Code and subject to the same efficiency and conservation standards applied to permanent District customers."

RECOMMENDATION(S):

Approve the proposed Policy for Temporary Meter Service.

FISCAL IMPACT:

No

ITEM BUDGETED:

Yes

FINANCIAL IMPACT:

There is no financial impact associated with this policy.

DISCUSSION:

Historical water usage through all temporary meters for the past five years is shown on Attachment A. Usage in 2013 and 2014 more than doubled, due in large part to demands associated with a temporary meter used by the Westlake Lake Management Association to maintain the water level in Westlake Lake. The practice was discontinued when the State passed emergency regulations mandating significant reductions in urban water usage. In spite of numerous construction projects and continuing drought conditions in 2015, water usage through temporary meters dropped significantly below the 2012 level. As the historical data shows, customers with temporary meters appear to have responded to reduce water usage as well as the District's permanent customers.

In 2015, potable water usage through temporary meters was 34.5 acre-feet, or approximately 0.2% of total potable water deliveries. As such, temporary potable meter service makes up a very small fraction of the District's overall demands. Furthermore, only about 30% of all temporary meter service is for domestic purposes. Given the limited usage, staff believes a broad policy framework is warranted to enable staff to address the varied needs of customers, particularly because temporary meters provide an essential service to a very small segment of customers who would otherwise be significantly impacted.

In implementing the policy, staff will update and streamline the reporting process to allow better tracking of actual water users, since some temporary meters are registered to water truck operators who conduct business in the area. Also, the recent implementation of water budgets creates a mechanism for setting a fair water budgets for all customers, including those receiving service through a temporary meter. Users would be notified that a water audit would be conducted if wasteful use appeared to be occurring based on the water budget for the site. However, staff has found that wasteful water usage is unusual with temporary meters because the cost of service water (1.5 times Tier 4) is adequate to encourage efficiency.

Another issue that staff would consider with implementation would be a requirement for temporary meter service customers to pay deferred standby charges, if any, prior to receiving service. Finally, staff would ensure that customers who can reasonably connect to the water system would do so in a timely manner rather than continuing to received temporary meter service.

GOALS:

Provide Safe and Quality Water with Reliable Services

Prepared by: Carlos G. Reyes, Director of Resource Conservation and Public Outreach

ATTACHMENTS:

Attachment A - Temporary Meter Usage

HISTORICAL USAGE

Year	HCF	Acre-Feet
2011	18,225	41.8
2012	27,658	63.5
2013	52,768	121.1
2014	70,050	160.8
2015	21,622	49.7

2015 USAGE DETAIL (graph below)

Use	HCF	Acre-Feet
Construction	7,300	16.8
Domestic	6,385	14.7
Other*	1,317	3.0
Recycled Water	6,620	15.2
Total	21,622	49.7

*Examples: Re-vegetation, street sweeping and tree wells watering

2015 potable water deliveries through temporary meters = 34.5 acre-feet

2015 potable water deliveries = 17,288 acre-feet

$(34.5/17,288) \times 100 = 0.2\%$

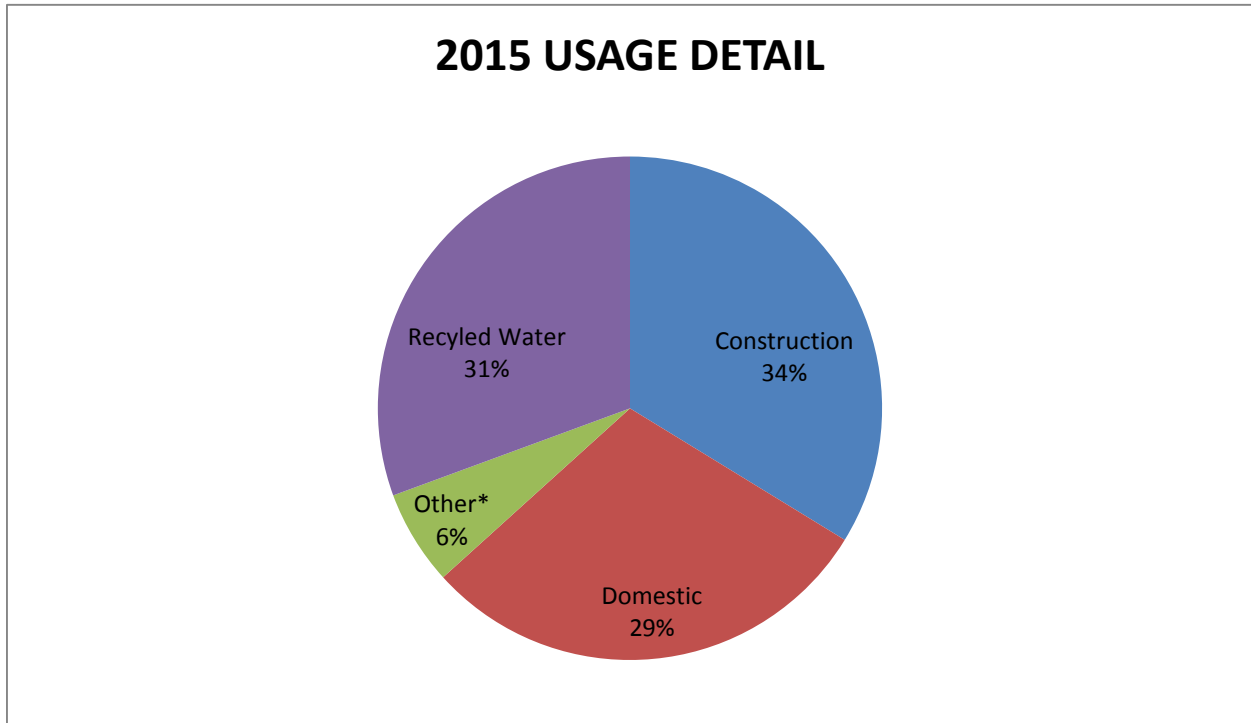



April 26, 2016 LVMWD Regular Board Meeting

TO: Board of Directors

FROM: Facilities & Operations

Subject : Saddletree Tank Rehabilitation Project: Change Order No. 1

SUMMARY:

On February 9, 2016, the Board awarded a construction contract to Paso Robles Tank, Inc., in the amount of \$364,674, for the Saddletree Tank Rehabilitation Project. Change Order No. 1, in the amount of \$8,907.69, was administratively approved by the General Manager on April 5, 2016. The revised contract amount is \$373,581.69. The change order addresses tank modifications necessary to bring the tank into compliance with Cal-OSHA regulations.

FISCAL IMPACT:

Yes

ITEM BUDGETED:

Yes

FINANCIAL IMPACT:

The adopted Fiscal Year 2015-16 Budget provided funding under CIP Job No. 10539, Saddletree Tank Rehabilitation Project, in the amount of \$554,606. No additional appropriation is required.

DISCUSSION:

Change Order No. 1 allows for the following tank upgrades to improve safety and comply with Cal-OSHA regulations:

1. Replacement of the existing 24-inch x 24-inch roof hatch with a new aluminum 39-inch x 39-inch hatch to meet minimum size requirements.

2. Installation of a Saf-T-Climb fall protection system to the exterior ladder.
3. Relocation of the roof hatch, including welded closure of the existing hatch and modification of hand railing, to provide a safe landing platform to minimize fall hazards and improve tank access.

GOALS:

Construct, Manage and Maintain All Facilities and Provide Services to Assure System Reliability and Environmental Compatibility

Prepared by: Eric Schlageter, P.E, Senior Engineer

ATTACHMENTS:

Change Order No. 1



4232 Las Virgenes Road
 Calabasas, California 91302-1994

CONTRACT CHANGE ORDER
 No. 1

Project Saddletree Tank Rehabilitation Project

Project No. Acct. No. 10539.1880.605

Contractor Paso Robles Tank

Date 03/31/2016

CONTRACTOR CHANGE ORDER NO. 1 The Contractor is hereby authorized and directed to make the herein described changes from the Plans and Specifications or do the following work not included in the Plans and Specifications for the construction of this project.

This change requested by: LVMWD

DESCRIPTION OF CHANGE:

	Description	Amount	Days
1	Replace the existing 24" x 24" roof hatch with a new aluminum 39" x 39" roof hatch for Cal-OSHA compliance	\$5,250.00	0
2	Installation of a Saf-T-Climb fall protection system to the exterior tank ladder for Cal-OSHA compliance	\$2,250.00	0
3	Relocation of the roof hatch location including welded closure of the existing penetration and modification of hand railing to provide a safe landing platform to minimize falling hazards and improve tank access.	\$1,407.69	1
	TOTAL	\$8,907.69	1

INCREASES
 TOTAL AT AGREED PRICES OR FORCE ACCOUNT \$8,907.69
 DECREASES

Contract Change Order No. 1 Project No. 10539 Acct. No. 1880.605

Date 03/31/2016

(2) Estimate of increases and/or decreases in contract items at contract unit prices:

INCREASES

Item	Description	Quantity	Unit Price	Total
TOTAL INCREASES				\$N/A

DECREASES

Item	Description	Quantity	Unit Price	Total
TOTAL DECREASES				\$N/A

TOTAL NET _____ IN CONTRACT ITEMS AT CONTRACT UNIT PRICES \$ _____

TOTAL COST OF THIS CHANGE ORDER \$8,907.69 INCREASE

DECREASE

It is agreed 1 consecutive calendar days extension of time will be allowed by reason of this change.

Recommended by

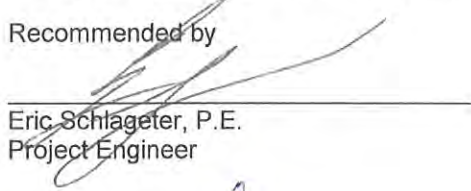
Eric Schlagefer, P.E.
Project Engineer

Departmental Approval

David R. Lippman
Director of Facilities and Operations

ACCEPTED:

By: Donny Cook Project Manager

Date: 4/5/16

APPROVED:

Las Virgenes Municipal Water District

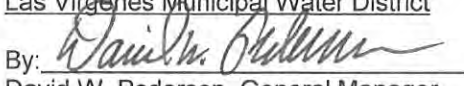
By: David W. Pedersen, General Manager

Date: 04/05/16

Note: Attention is called to the sections of the Special Provisions and Standard Provisions on EXTRA, ADDITIONAL OR OMITTED WORK.

- THIS CHANGE ORDER IS NOT EFFECTIVE UNTIL APPROVED BY OWNER
- IF ACCEPTABLE TO THE CONTRACTOR, THIS CHANGE ORDER IS EFFECTIVE IMMEDIATELY

Proposed Change Order (PCO)

RESET FORM

Job Number: 41004		Job Name: Saddle Tree Tank Rehabilitation		PCO Title/Description: 39" sq Alumin Roof Htch, Safety Clim, Hand Rail, Patch Plate		Date: 3/24/2016	PCO Type: CONTRACT 1	PCO No.:
Owner: Las Virgenes Municipal Water District		Customer: Same		Per Diem Rate: \$35.00		Qry/Days: 1.0	Benchis: \$0.00	Tracking Code: 1050 - Carbon Field
Item	Cher	ST Hours	OT Hours	ST Rate	OT Rate	Labor Total	Per Diem Rate	Tracking Code
1	AREA 1 BOILERMAKER-BLACKSMITH	3.00		\$72.80		\$218.40	\$100.00	1041 - Carbon Shop - Paso
2	NON-PREVAILING CARBON SHOP	7.00		\$23.00		\$161.00		7201 - Paso Paint Shop - Labor
3	NON-PREVAILING PAINT SHOP	5.00		\$23.00		\$115.00		
4	PAINTER Los Angeles INDUSTRIAL COATER	2.00		\$42.77	\$57.88	\$85.54	\$100.00	
5	SELECT CRAFT							SELECT CODE
6	SELECT CRAFT							SELECT CODE

Equipment:									
Item	Description	Quantity	ST Quantity	OT Quantity	ST Rate	OT Rate	Standby Rate	Total	Tracking Code
1	Welding Machine, 500A+	1			\$150.00	\$0.00	\$0.00	\$150.00	4005 - Misc. Equip Rental
2								\$0.00	SELECT CODE
3								\$0.00	SELECT CODE
4								\$0.00	SELECT CODE
5								\$0.00	SELECT CODE
6								\$0.00	SELECT CODE

Materials:									
Item	Description	Quantity	Unit of Measure	Unit Price	Total	Tax Rate	ST Quantity	OT Quantity	Tracking Code
1	HDG Safety Climb	1		\$2,250.00	\$2,250.00	0.00%			SELECT CODE
2	39 SQ ALUMINUM ROOF HTCH	1		\$5,250.00	\$5,250.00	0.00%			2007 - Carbon - Appr/Nozzles/Misc
3	1 1/2 PIPE	30'		\$75.00	\$23.00	8.00%			2008 - Carbon - Roof Structure
4	1/4X 4" FB	10'		\$23.00	\$23.00	8.00%			2008 - Carbon - Roof Structure
5	30"X30" PLATE	1		\$42.50	\$42.50	8.00%			2008 - Carbon - Roof Structure
6				\$0.00	\$0.00	0.00%			SELECT CODE
7				\$0.00	\$0.00	0.00%			SELECT CODE
8				\$0.00	\$0.00	0.00%			SELECT CODE

Subcontractors:									
Item	Name	Description	Total	Tracking Code					
1				SELECT CODE					
2				SELECT CODE					
3				SELECT CODE					
4				SELECT CODE					
5				SELECT CODE					

Other:									
Item	Name	Description	Total	Tracking Code					
1				SELECT CODE					
2				SELECT CODE					

Total Calendar Days Requested:		1		Name:		Date:	
Signature of Supervisor		Name:		Date:		Date:	

Summary of Charges		Date:	
Labor	Cost	\$964.65	
	Surcharge %	\$0.00	
	Markup %	\$144.70	15.00%
	Total	\$1,093.35	
Equipment	Cost	\$150.00	
	Markup %	\$0.00	
	Total	\$150.00	
Material	Cost	\$7,640.50	
	Tax	\$7.84	
	Markup %	\$0.00	
	Total	\$7,648.34	
Subcontractor	Cost	\$0.00	
	Markup %	\$0.00	
	Total	\$0.00	
Freight	Cost	\$0.00	
	Markup %	\$0.00	
	Total	\$0.00	
Bonding	Cost	\$0.00	
	Bonding %	\$0.00	
	Total	\$0.00	
Overhead (Contract)	Cost	\$0.00	
	Overhead %	\$0.00	
	Total	\$0.00	
Profit	Cost	\$0.00	
	Profit %	\$0.00	
	Total	\$0.00	
PCO Total:		\$8,907.69	